

WINCO[®] GENERATORS

 An American Company.
We produce our products in our 200,000ft² facility located in Le Center, Minnesota, equipped with modern engineering, fabrication and assembly capabilities.



YOUR GEN



LED Display

Hours, RPMs, voltage, and frequency readings automatically cycle on the display.

Load Bars

Easily verify the load balance on each leg of the generator end.

Warnings

The LED will flash if any parameter gets outside of normal range. A warning will also be displayed when it is time for an oil change.

Receptacle Panel

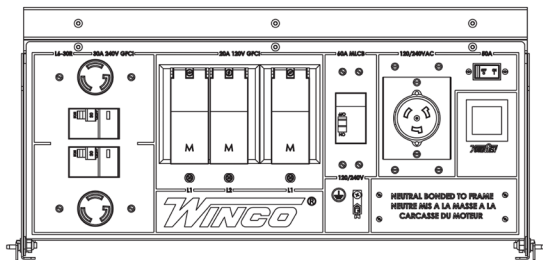

WL16000HE-03/B 14,000 RUNNING WATTS

Rugged Steel Design.



Honda Commercial iGX800 Engine.

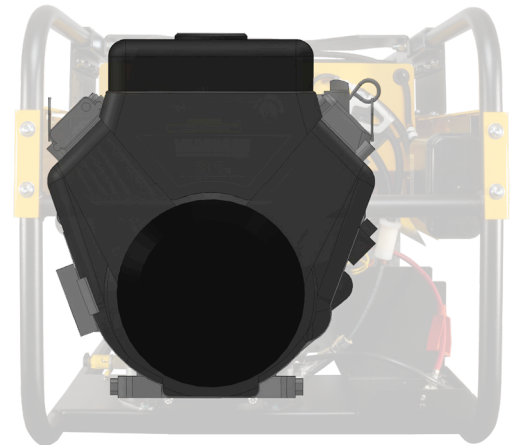

Brushless Industrial Genend.

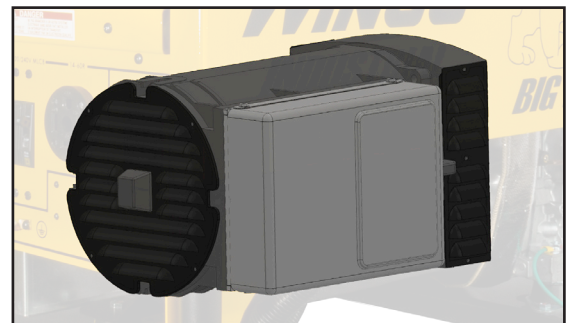

SPECIFICATIONS

ENGINE

ENGINE BRAND	HONDA
ENGINE MODEL	iGX800
ENGINE STARTER	ELECTRIC
ENGINE SPEED	3600 RPM
ENGINE CYLINDERS	V-TWIN
DISPLACEMENT/TYPE	779 CC / OHV
FREQUENCY REGULATION ⁽¹⁾	+/- 3%
LOW OIL PROTECTION	STANDARD
RECOMMENDED OIL ⁽²⁾	5W-30
OIL CAPACITY	2.1 QT
FUEL TANK	15 GAL
FUEL GAUGE	YES
FULL LOAD RUN TIME ⁽³⁾	7 HOURS
FUEL CONSUMPTION	GAL/HR
100%	2.10
75%	1.71
50%	1.35
25%	0.96
0%	0.57
BATTERY SIZE ⁽⁴⁾	BCI GROUP U1 300CCA

NOTES: (1) Steady state frequency regulation. (2) The recommended oil is for normal applications. See operator's manual for the recommended oil for your needs. (3) Run time is estimated. (4) Battery not included.

SHIPPING

SHIPPING DIMENSIONS (L x W x H)	49.5" x 27" x 30"
SHIP WEIGHT	504 LBS
FREIGHT CLASS	70

OPTIONAL ACCESSORIES

FOUR-WHEEL DOLLY KIT	WITH FLAT-FREE TIRES
COVER	50" x 28" x 30.5"
BATTERY	BCI GROUP U1 300 CCA
MAINTENANCE KIT	16200-031

ELECTRICAL

STARTING WATTS	16,000
RUNNING WATTS	14,000
RUNNING AMPS @ 120 VAC	116
RUNNING AMPS @ 240 VAC	58
VOLTAGE REGULATION	CAPACITOR +/- 5%
MAIN CIRCUIT BREAKER	60 AMP, 240V VAC
BONDED NEUTRAL	YES
120 VOLT RECEPTACLES	(3) NEMA 5-20 20A DUPLEX (GFCI)
120/240 VOLT RECEPTACLES	(1) CS6369 50A
240 VOLT RECEPTACLE	(2) NEMA L6-30 30A (GFCI)
YOURGEN METER	STANDARD

GENSET

MOTOR STARTING (CODE G)	4 HP
DBA @ 7 METERS	82
TOTAL HARMONIC DISTORTION	< 5%
LIFTING EYE ⁽¹⁾	STANDARD
4-WHEEL DOLLY KIT	OPTIONAL
INSULATION	CLASS H
PROTECTIVE ROLL FRAME	1.25" DIA. 14 GA. STEEL
ASSEMBLED IN	USA
EPA APPROVED	YES
CARB APPROVED	NO
TÜV CERTIFICATION	CSA
UNIT WARRANTY ⁽²⁾	3 YEARS COMMERCIAL

NOTES: (1) Shipping eye shipped loose. (2) For more generator warranty, see operator's manual.



Specifications are subject to change without notice.

