

MODEL: DL9000E/A, DL9500HE/A

CONTROL PANEL WIRING DIAGRAM

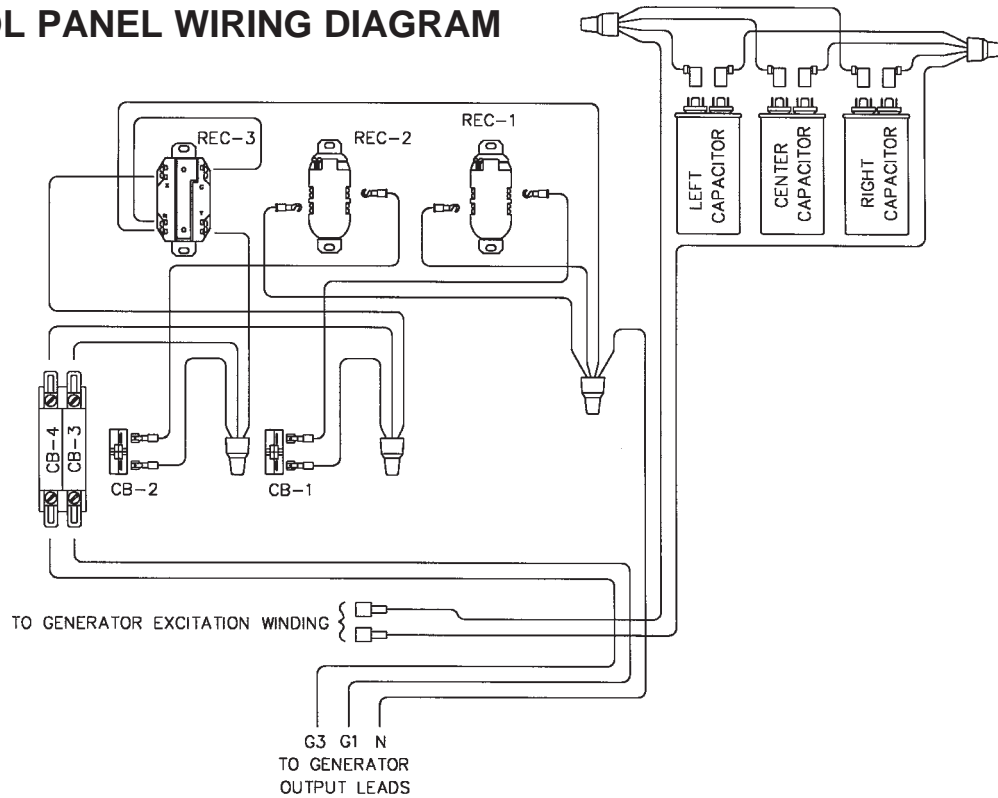

GENERATOR SCHEMATIC

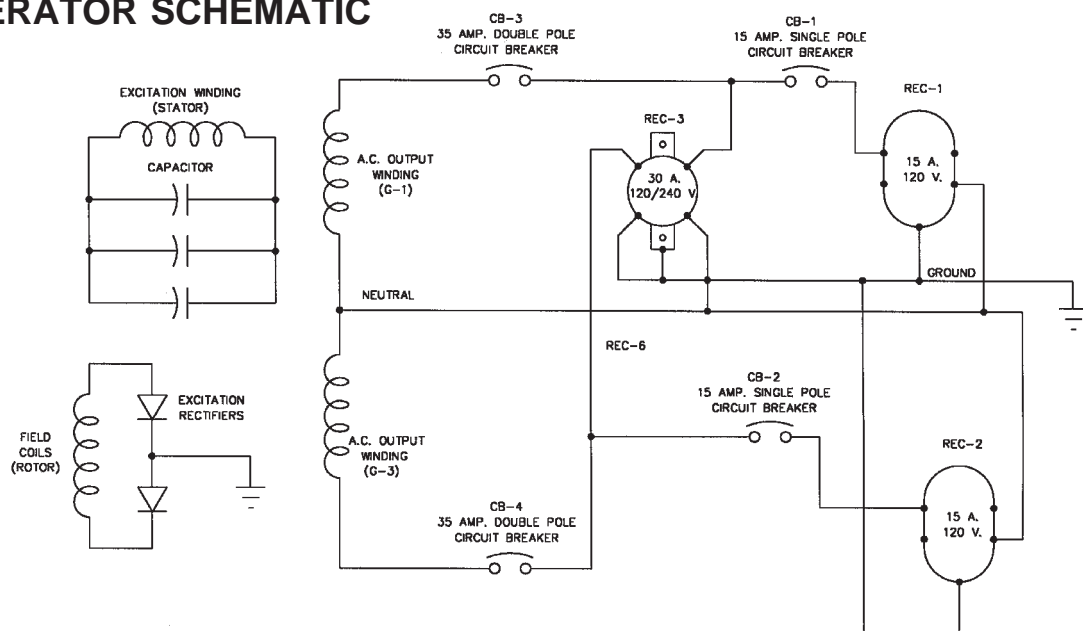

COMPLETE UNIT ASSEMBLY

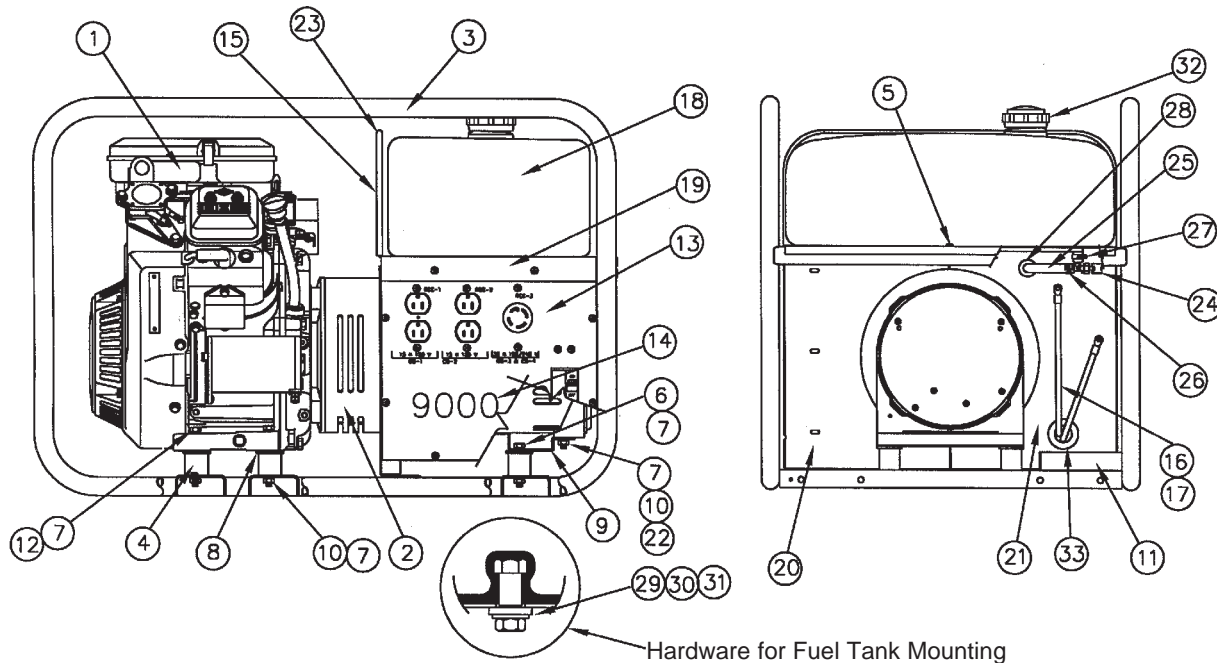

REF	PART NBR	QTY	DESCRIPTION
1	15456-000	1	Engine (Briggs 303447-1042-E1)
	15959-000	1	Engine (Honda GX610VZANH1)
2	15041-020	Ref.	Generator Unassembled
3	63073-005	1	Cradle
4	64062-000	6	Shockmounts
5	21698-001	1	#10 X 3/8 Self Tapping Screw
6	477-000	2	5/16-18 X .63 Hex Head Bolt
7	480-000	14	5/16 Split Lockwasher
8	23760-000	6	1.50 O.D. X .344 I.D. Flat Washer
9	15084-000	1	Generator Support Bracket
10	458-000	8	5/16 Hex Nut
11	15676-001	1	Battery Tray
12	9416-000	4	5/16-18 X 1.75 Hex HD Bolt
13	15457-007	Ref.	Receptacle Box
14	15370-011	1	Model Decal
15	15370-000	1	DYNA Decal
16	15767-006	1	Pos. Battery Cable
17	15767-007	1	Neg. Battery Cable
18	64024-000	1	4.5 Gallon Fuel Tank
19	15462-011	1	Fuel Tank Tray
20	15223-007	1	Left Support Panel
21	15222-014	1	Right Support Panel
22	580-000	2	5/16 - 18 X 1.25 Hex Head Bolt
23	58684-000	30 "	Edge Trim
24	98771-000	1	Fuel Line Valve

REF	PART NBR	QTY	DESCRIPTION
25	40078-000	26"	Fuel Hose
26	62999-001	2	Hose Clamp
27	81018-008	1	Clamp
28	23917-000	1	Grommet
29	466-000	2	1/4-20 X .75 Hex HD Bolt
30	512-000	2	1/4 Flat Washer
31	16133-000	2	3/4 O.D. X 1/4 I.D. X 1/8 Flat Washer
32	15482-000	1	Fuel Cap
33	62486-000	1	Grommet
NI	63941-001	1	Hot Warning Decal
NI	15209-000	1	Danger Decal Set

CONTROL PANEL ASSEMBLY

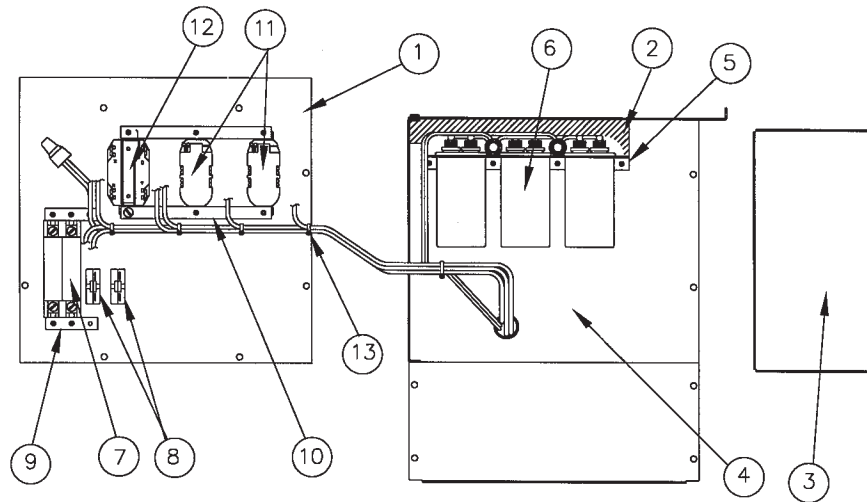

REF	PART NBR	QTY	DESCRIPTION
1	15458-007	1	Front Panel (bare)
2	15167-000	1	Foam
3	15221-002	1	End Panel
4	15221-005	1	Bottom, Top and Back Panel
5	15226-000	1	Capacitor Clamp
6	15051-000	3	Capacitor
7	57030-003	1	35 A, 240 v Circuit Breaker
8	91286-000	2	15 A, 120 V Circuit Breaker
9	64045-012	2	Mounting Strap
10	64045-006	2	Mounting Strap
11	24749-000	2	15 A. 120 V Receptacle
12	97360-000	1	30 A. 120/240 V Receptacle
13	49975-010	15	Cable Ties

GENERATOR PARTS LIST

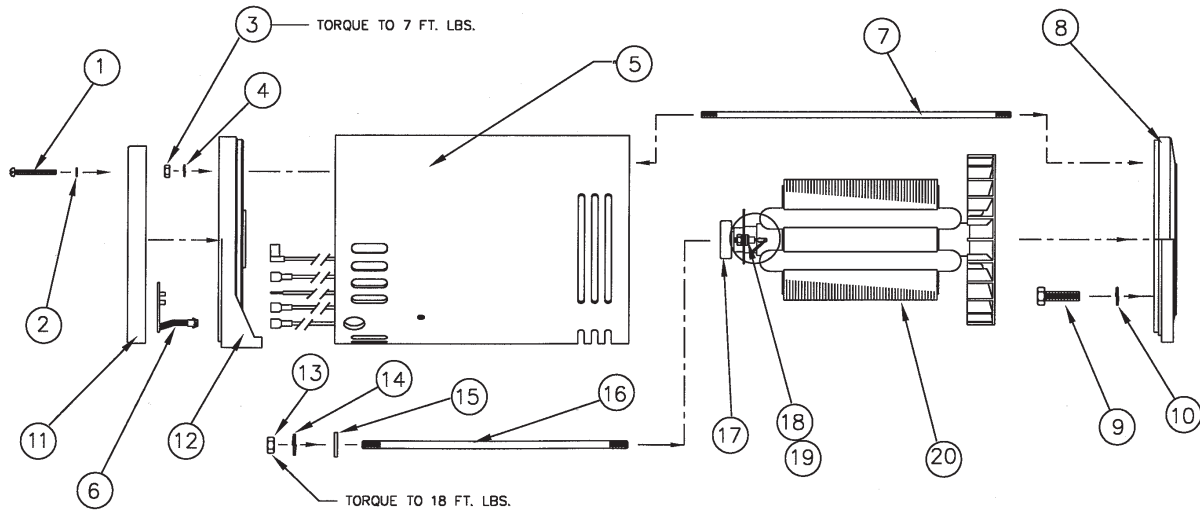

REF	PART NBR	QTY	DESCRIPTION
1	15013-001	4	#10-32 X 1.75 Screw
2	21975-000	4	#10 Lockwasher
3	15192-000	4	1/4-20 Hex Nut
4	479-000	4	1/4 Lockwasher
5	15091-006	1	Stator
6	15110-000	1	Converter Module
7	15068-010	4	1/4-20 Stator Bolt
8	15008-000	1	Engine Mtg Brkt
9	91658-003	4	3/8-16 X 1.5 Cap Screw
10	481-000	4	3/8 Lockwasher
11	15085-000	1	End Cover
12	15156-003	1	Bearing Brkt
13	15193-000	1	5/16-20 Hex Nut
14	480-001	1	5/16 Lockwasher
15	23558-000	1	11/32 x 1 1/8 Flat Washer
16	23197-028	1	1/16 X 12 1/8 Thru Bolt
17	50215-000	1	Bearing
18	15255-001	1	Diode (std)
19	15255-002	1	Diode (rev)
20	15045-009	1	Rotor, Complete

GENERATOR SPECIFICATIONS

Rotor	0.73 Ohms
G1 to N	0.125 Ohms
G3 to N	0.125 Ohms
Capacitor Leads	0.23 Ohms
AC Residual Voltage	7.0 VAC G1 to G3
Winding Spec.	SS#1538
AC Connection	AC#367

WINGO[®] INC
A Division of DTF Dyna Technology Inc

225 South Cordova Avenue
 Le Center MN 56057
 507-357-6831