

MODEL 45/25PTCD
TYPE 1

MODEL 45/25PTC/52
TYPE 2

REF. NO.	PART DESCRIPTION	PART NO	REQ'D/UNIT
1	Panel Front	G-7231	1
2	Panel Back Assembly	G-5434-37	1
3	Bearing Retainer	W-43	1
4	Field Frame Assembly	G-5432-21	1
5	Field Frame	G-6362	1
6	Brush Gear Assembly	G-5430-1	1
7	Tinnerman	4996	6
8	Brush	Y-51	9
9	Brush Spring	G-3422	9
10	Bearing - Slip Ring End	D-8	1
11	Not Applicable		
12	Armature	G-4766-72	1
13	Fan Assembly	G-5878-2	1
14	Washer	S-7019	1
15	Bearing - DE	D-3	1
16	Grease Seal	TE-888	1
17	Sprocket - Lower - 3 Row	S-6350-1	1
18	Washer	1207	1
19	Screw	11320-2	1
20	Key - Sprocket	S-2056-83	1
21	Key - Fan	S-2056-90	1
22	Not Applicable		
23	Coil Shield	J-635	8
24	Field Pole	G-5037	4
25	Field Coil	H-1094	4
26	Panel Top Cover	S-7623-2	1
27	Wrapper	S-7037	1
28	Gear Case Housing Assembly	G-5922	1
29	Housing	I-885	1
30	Bearing Cap	D-27	1
31	Drive Shaft Assembly	G-5925	1
32	Bearing Cone	D-28	1
33	Sprocket 3 Row	S-7301	1
34	Shaft 6 Spline 1-3/8 ASAE	N-593	1
35	Bearing Cone	D-70	1
36	Gasket	X-197	1
37	Bearing Cup	D-71	1
38	Gear Case Cover	I-884	1
39	Gear Case Cover Assembly	G-5924	1
40	Not Applicable		
41	Retainer Plate	I-883	1
42	Seal - Upper	X-201	1
43	PTO Guard	S-7606	1
44	Washer - Hardened	S-7046	1
45	Key	S-2056-86	1
46	Drive Chain - 3 Row	G-7283	
47	Vent Cap	10801	1

Wiring Diagram IE-9660-3
Parts Drawing IE-9670

Last Revision None

PL-2007-1
(Sheet 1 of 2)

3-29-79 EJ

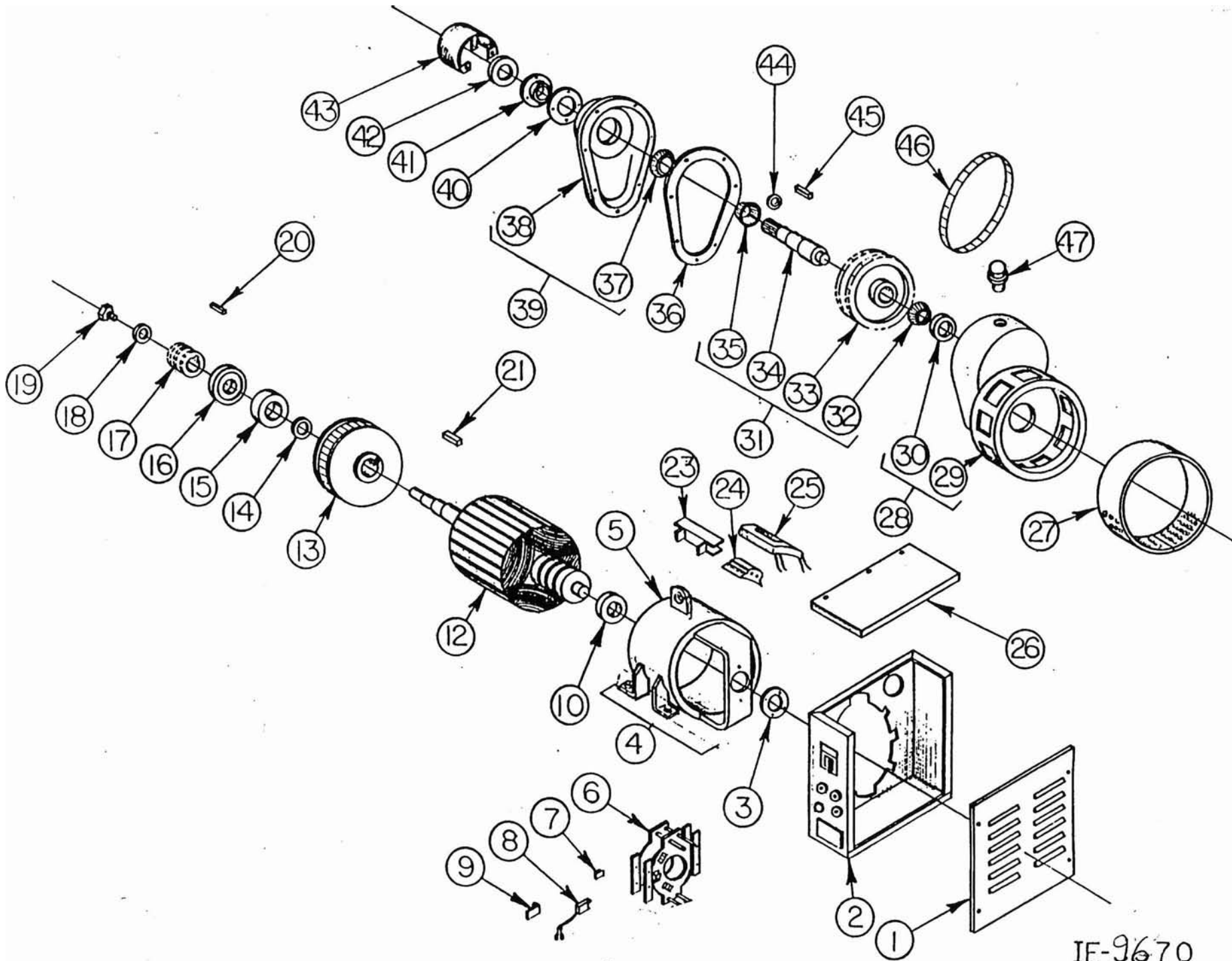

IE-9670

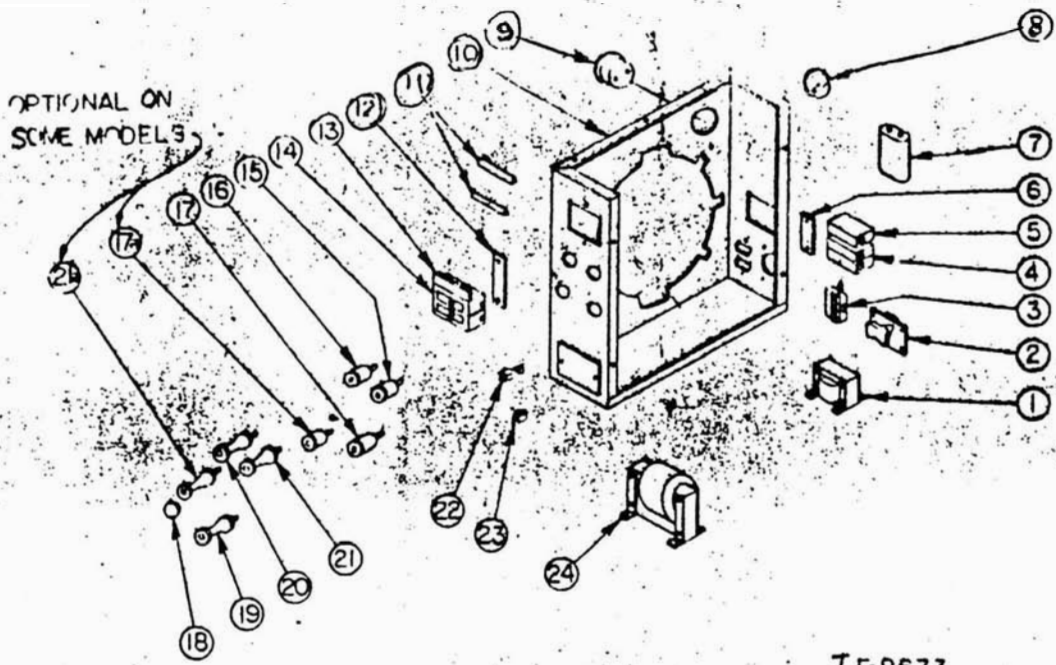

IE-9673

		PANEL ASSEMBLY G-5434-37	
REF. NO.	PART DESCRIPTION	PART NO.	REQ'D
1	Choke	EE-2272	1
2	Receptacle - 250 Volt	EE-399	1
3	Receptacle - Duplex	EE-323	1
4	Circuit Breaker 50 Amp	EE-1805	1
5	Circuit Breaker 15 Amp	EE-1830	1
6	Mounting Plate	S-5027-1	1
7	Capacitor	EE-1539	1
8	Rectifier Assembly Shunt	EE-2214	1
9	Voltmeter	VM-716	1
10	Panel Weld Assembly	G-5838-28	1
11	Insulator	W-203	2
12	Mounting Plate	S-5027-1	1
13	Filler Plate Breaker	EE-779	1
14	Circuit Breaker	EE-1806	1
15-21	Not Applicable		
22	Ground Lug	EE-1671	1
23	Tinnerman	4957	7
24	Transformer	EE-1979	1
N.S.	Load Plug Bracket	S-9292	2
N.S.	2 Pole Load Plug Housing	EE-2327	2
N.S.	Load Plug Terminals	EE-2328	4
(B) N.S.	Voltmeter Shield	S-9675	1

Wiring Diagram IE-9660-3
 Parts Drawing IE-9673

(A) Was VM-71 6-1-82
 (B) Added 6-1-82

PL-2007-2
 (Sheet 2 of 2)

