



ILLUSTRATED PARTS LIST

ULPSS90-3/B & /C

ULPSS90-4/B & /C

ULPSS90-17/B & /C

ULPSS90-18/B & /C

**WITH DSE 7110 & DSE7310
ENGINE CONTROL**

**225 S. CORDOVA AVE.
LECENTER, MN 56057
507-357-6821
SERVICE DEPT.
507-357-6831
wincogen.com**

GENERATOR ASSEMBLY

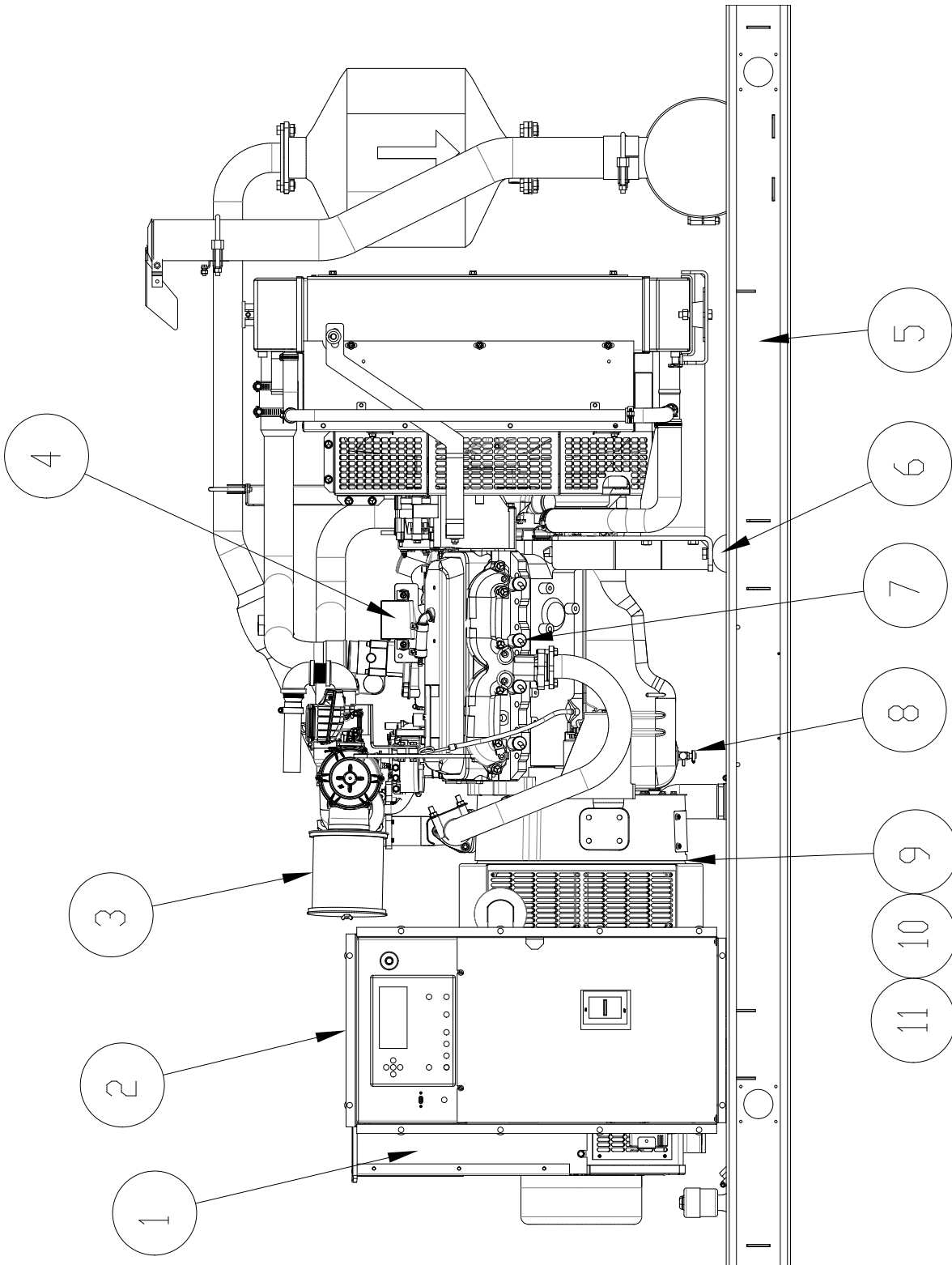

REF #	PART NUMBER	QTY	DESCRIPTION
1	SEE TABLE	1	Generator, Stamford Newage
2	Reference	1	Control Cabinet Assembly
3	97294-005	1	Air Filter Assembly
3	AF1-15ULSP3	1*	Air Filter with 3" Hose Adapter
4	351987-9	1	Engine GM 5.7 Liter Turbo
5	99309-090	1	Welded Base Assembly
6	98956-001	4	Shockmount
7	R42LTS or R44LTS	8**	Spark Plug
8	98906-009	1	Oil Drain Valve
9	96000-004	12	3/8"-16 X 1.5" Bolt
10	96000-002	8	.375-16 X 1" Bolt
11	481-001	20	Lock Washer
NI	93824-003	1	Petcock Valve
NI	55505-000	6 FT	3/8" Hose
NI	94319-008	2	Hose Fitting
NI	93084-000	2	1/2" Pipe Plug
NI	62625-004	2 FT	Insulated Sleeving
NI	PF454	1**	Oil Filter, AC Delco
NI	99317-001	1	Battery Tray
NI	53220-013	1	Negative (-) Battery Cable
NI	53220-058	1	Positive (+) Battery Cable
NI	350818-2	1	Voltage Regulator AS440UL
NI	72036-015	1	2 Amp Battery Charger
NI	99420-023	1	GM DC Engine Harness
NI	Not Illustrated		
*	Impco Part #		
**	AC Delco Part #		

MODEL #	STAMFORD NEWAGE MODEL #	WINCO PART #
ULPSS90-3/B ULPSS90-3/C	UCI274C1J 4-LEAD	352013-1
ULPSS90-4/B & C ULPSS90-17/B & C ULPSS90-18/B & C	UCI274C1L 12-LEAD	352013-2

BLOCK HEATER ASSEMBLY

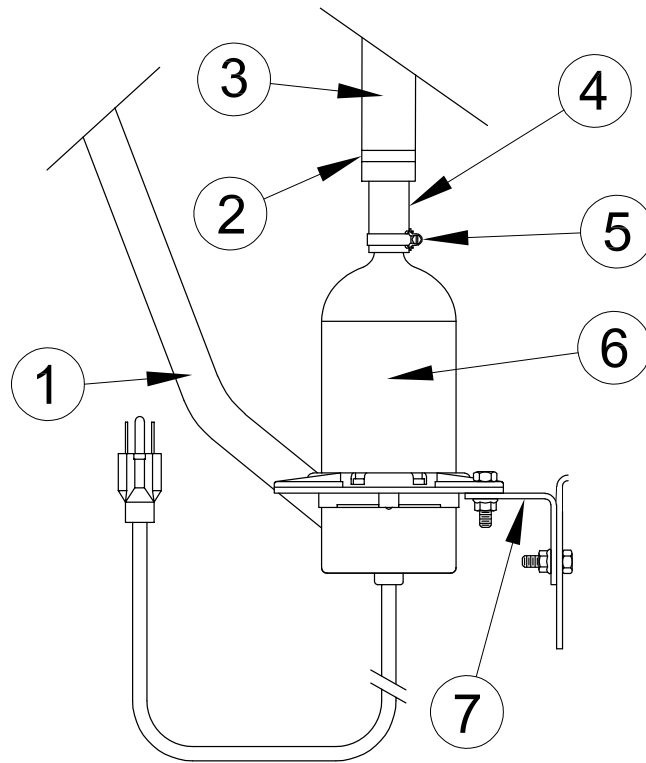

REF #	PART NUMBER	QTY	DESCRIPTION
1	93689-001	4 FT	5/8" Hose
2	Reference	4	Zip Tie
3	62625-004	4 FT	Hose Heat Sleeve
4	93689-001	3 FT	5/8" Hose
5	81018-005	4	Hose Clamp
6	80781-003	1	1000W 120V Tank Heater
7	Reference	1	Mounting Bracket

ENGINE CONTROL ASSEMBLY ULPSS90/B WITH DSE 7110

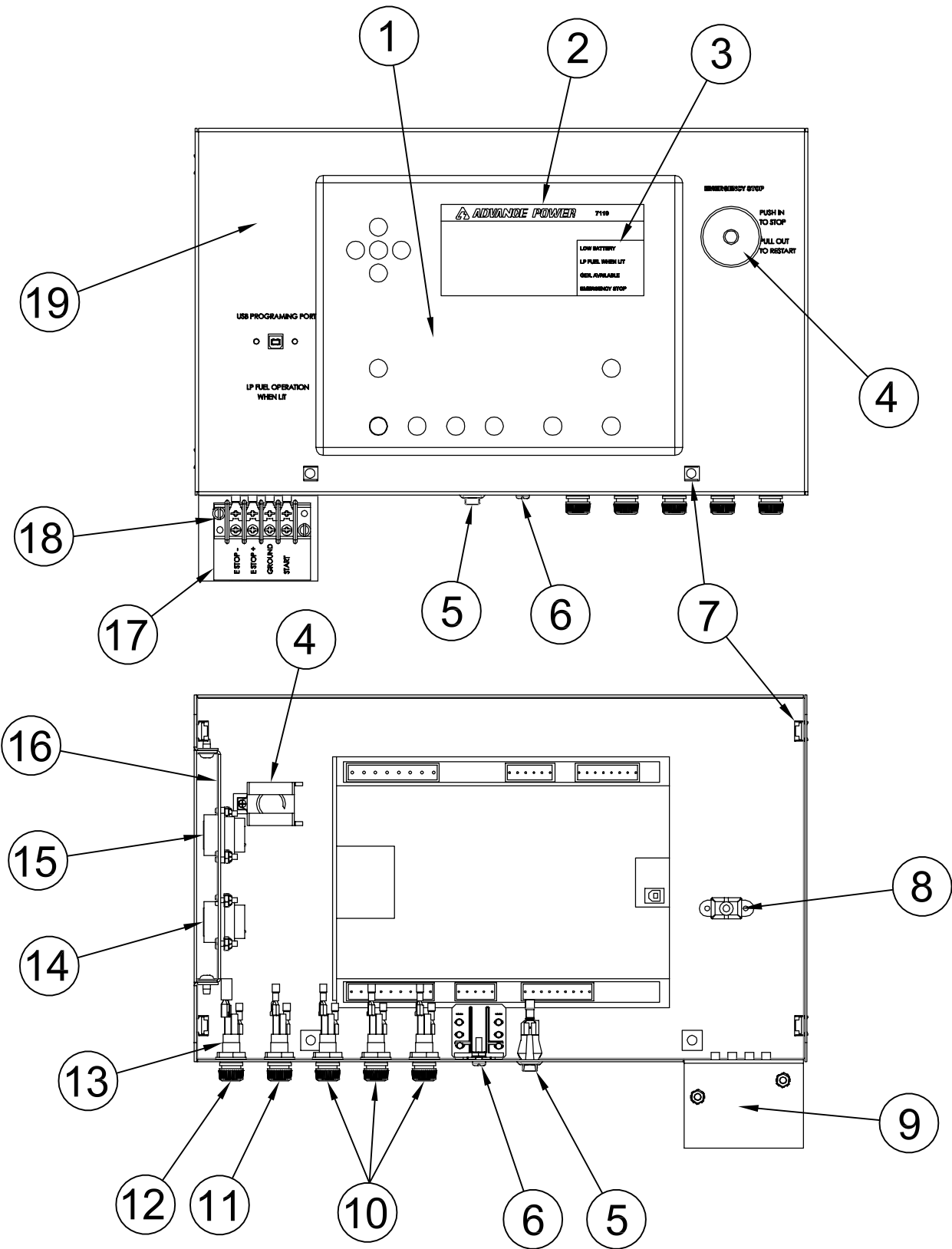

REF #	PART NUMBER	QTY	DESCRIPTION
1	351112-3	1	DSE 7110 Controller
2	1660-001	1	Advance Power Insert
3	16601-003	1	LED Legend Insert
4	99783-002	1	Emergency Stop Switch
5	64089-000	1	SPST Rocker Switch
6	59944-017	1	DPDT Relay 12VDC 10 Amp
7	92495-000	6	Retainer Nut
8	92844-005	1	USB Cable
9	99826-196	1	DC Box
10	95064-002	3	2 Amp Fuse
11	95064-000	1	3 Amp Fuse
12	95064-006	1	10 Amp Fuse
13	2489-001	5	Fuse Holder
14	96925-006	1	16 Pin Connector
15	96925-002	1	14 Pin Connector
16	351900-11	1	Connector Plate
17	64576-019	1	Remote Terminal Decal
18	80623-008	1	4 Point Terminal Block
19	99055-037	1	Control Panel
NI	99783-002	1	E Stop Contact
NI	Not Illustrated		

ENGINE CONTROL ASSEMBLY ULPSS90/C WITH DSE 7310

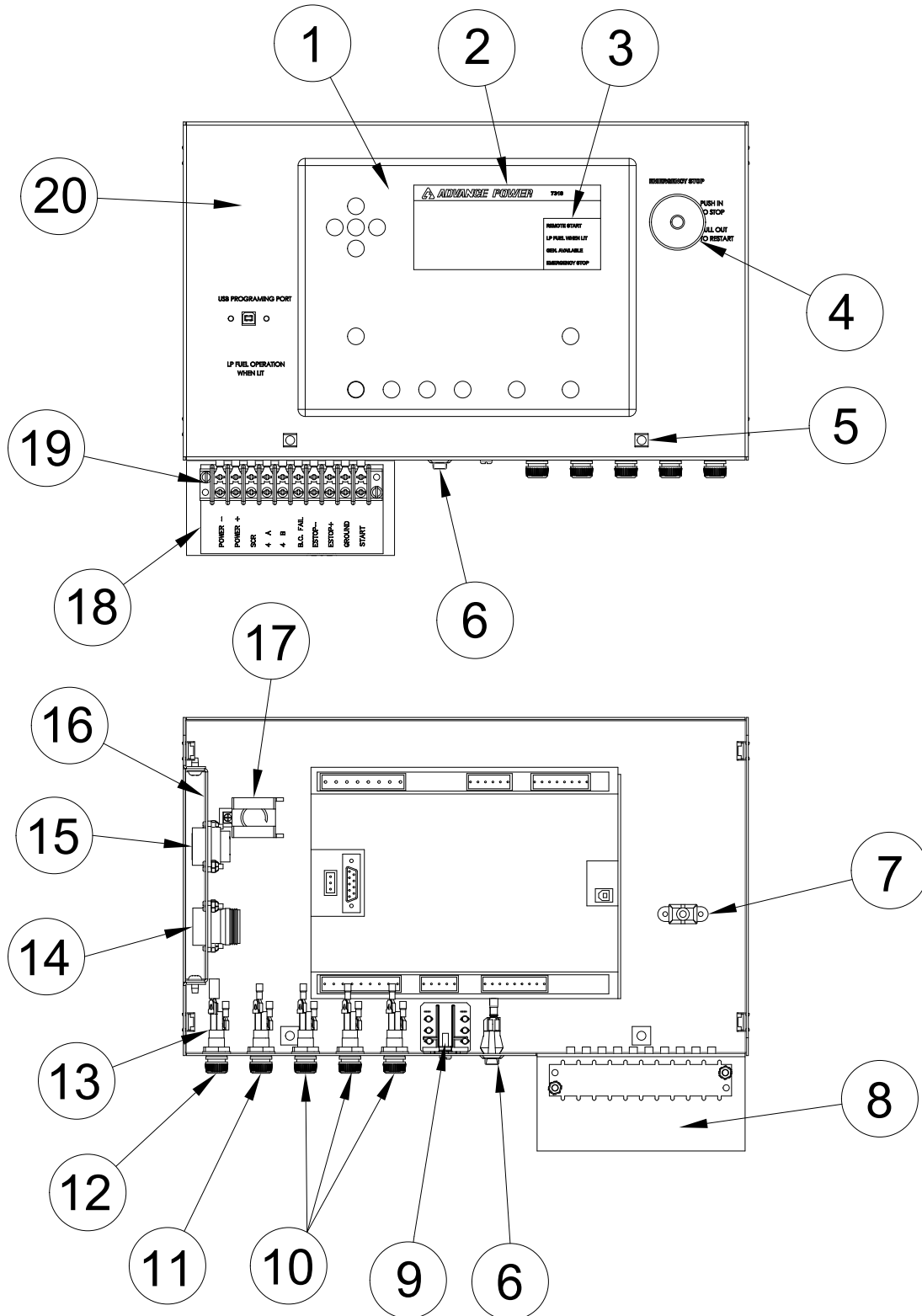

REF #	PART NUMBER	QTY	DESCRIPTION
1	351112-4	1	DSE 7310 Controller
2	1660-001	1	Advance Power Insert
3	16601-001	1	LED Legend Insert
4	99783-001	1	Emergency Stop Switch
5	92495-000	6	Retainer Nut
6	64089-000	1	SPST Rocker Switch
7	92844-005	1	USB Cable
8	99826-196	1	DC Box
9	59944-017	1	DPDT Relay 12VDC 10 Amp
10	95064-002	3	2 Amp Fuse
11	95064-000	1	3 Amp Fuse
12	95064-006	1	10 Amp Fuse
13	2489-001	5	Fuse Holder
14	96925-006	1	16 Pin Connector
15	96925-002	1	14 Pin Connector
16	351900-11	1	Connector Plate
17	99783-002	1	E Stop Contact
18	64576-019	1	Remote Terminal Decal
19	80623-006	1	10 Point Terminal Block
20	99055-038	1	Control Panel

DECALS

REF #	PART NUMBER	QTY	DESCRIPTION
NI	97813-000	3	Warning Auto Start Decal
NI	63941-001	1	Hot Surface Decal
NI	15209-000	1	UL Decal Set
NI	15209-100	1	French UL Decal Set
NI	16502-001	1	AC Disconnect Decal
NI	63941-003	1	Battery Compartment Decal
NI	63941-005	1	Receptacle Caution Decal
NI	15210-010	1	UL Fuel System Decal

CONTROL CABINET ASSEMBLY

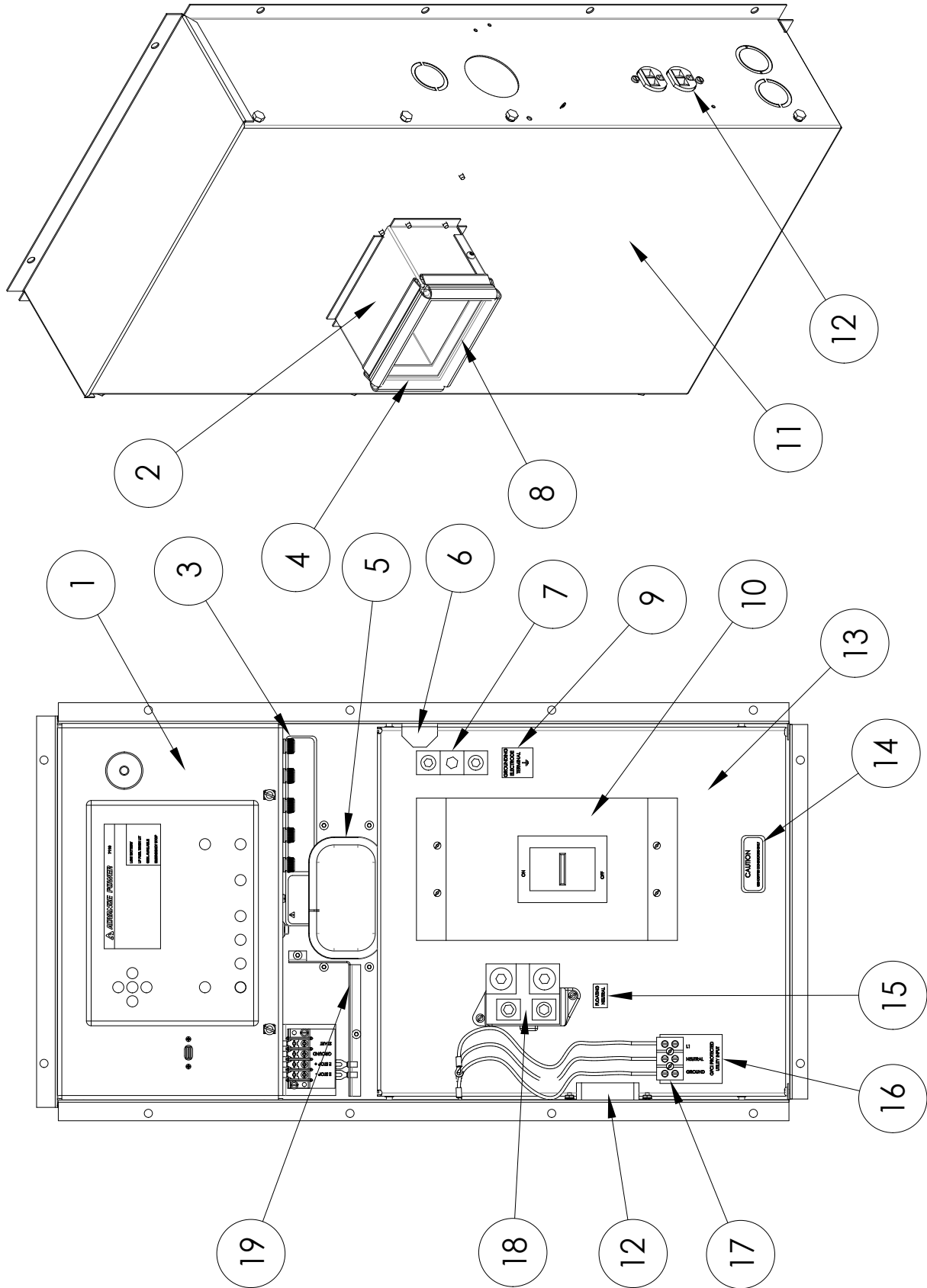

REF #	PART NUMBER	QTY	DESCRIPTION
1	99775-003	1	DSE 7110 Control Assembly
1	99775-000	1	DSE 7310 Control Assembly
2	99826-391	1	Conduit Panel
3	63941-007	1	Fuse ID Warning Decal
4	15287-000	2	3 3/8" Air Seal
5	58684-000	12 5/8"	Edge Trim
6	99826-194	1	Door Latch
7	58060-000	2	Ground Lug
8	15287-000	2	5 1/4" Air Seal
9	16499-000	1	Grounding Decal
10	SEE TABLE	1	Circuit Breaker
11	99826-390S	1	Circuit Breaker Cabinet
12	24749-000	1	Duplex Receptacle
13	SEE TABLE	1	Circuit Breaker Mounting Panel
14	16503-000	1	Copper Conductor Decal
15	16501-000	1	Floating Neutral Decal
16	64576-006	1	GFCI Protected Decal
17	51795-000	1	3 Point Terminal Block
18	350124-2	1	Neutral Block
19	99826-197	1	DC Box
NI	300538-23	1	Wire Harness Kit
NI	SEE TABLE	1	Circuit Breaker Cover Panel
NI	Not Illustrated		

MODEL #	PART #	DESCRIPTION
ULPSS90-3/B ULPSS90-3/C	81094-709 92076-003 99826-290S	350 Amp 240 Volt 2-Pole Breaker Circuit Breaker Mounting Panel Circuit Breaker Cover Panel
ULPSS90-4/B ULPSS90-4/C	81096-708 92076-004 99826-291S	300 Amp 240 Volt 3-Pole Breaker Circuit Breaker Mounting Panel Circuit Breaker Cover Panel
ULPSS90-17/B ULPSS90-17/C	81096-707 92076-004 99826-292S	250 Amp 240 Volt 3-Pole Breaker Circuit Breaker Mounting Panel Circuit Breaker Cover Panel
ULPSS90-18/B ULPSS90-18/C	81097-038 92076-016 99826-293S	125 Amp 600 Volt 3-Pole Breaker Circuit Breaker Mounting Panel Circuit Breaker Cover Panel

EXHAUST ASSEMBLY

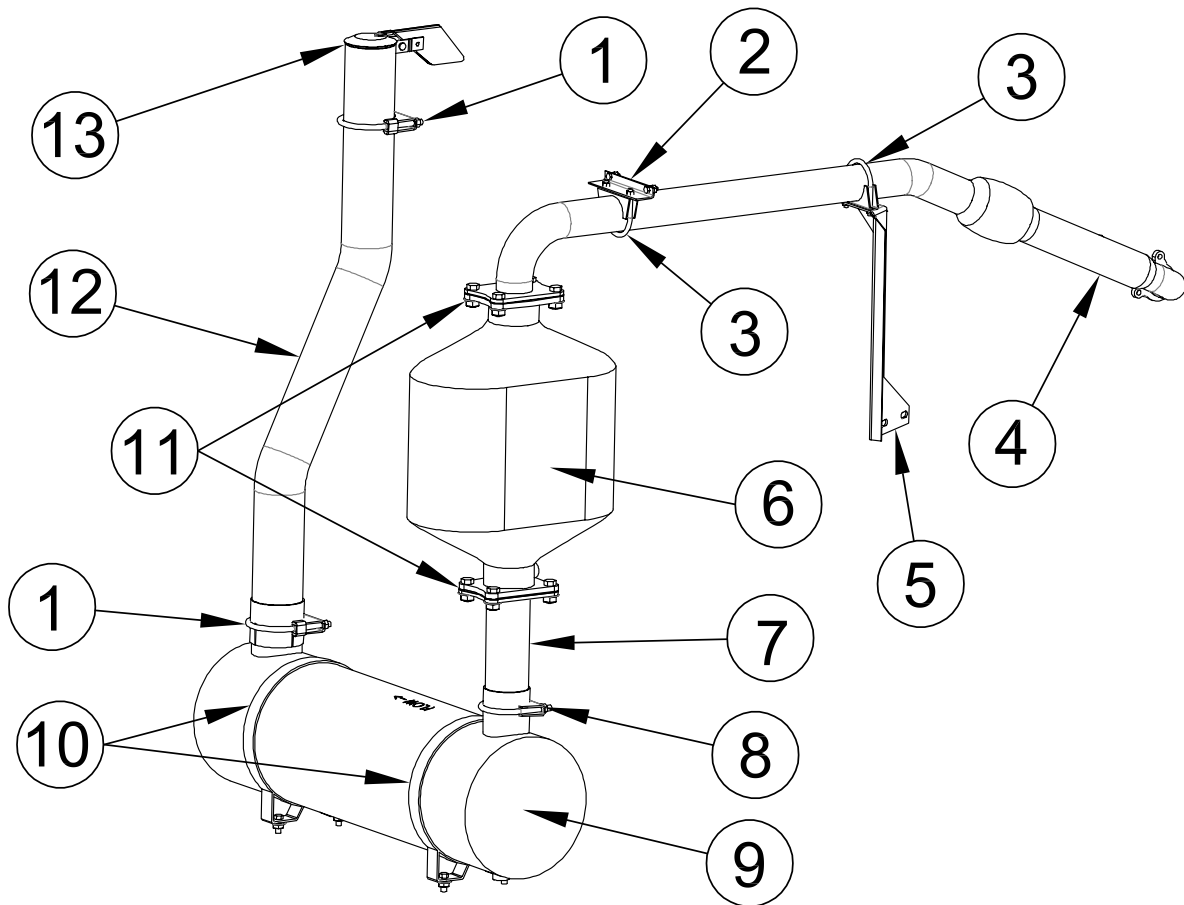

REF #	PART NUMBER	QTY	DESCRIPTION
1	93489-000	2	3 1/2" Muffler Clamp
2	16009-002	1	Exhaust Support
3	93489-002	2	2 1/2" Muffler Clamp
4	99289-025	1	Exhaust Flex
5	16009-003	1	Exhaust Support Bracket
6	351999-1	1	Catalytic Converter
7	99298-026	1	Exhaust Pipe
8	93489-001	1	3 3/8" Muffler Clamp
9	80519-014	1	Muffler
10	350264-1	2	Mounting Band
11	300541-3	2	Exhaust Gasket
12	99298-027	1	Tail Pipe
13	53111-005	1	3 1/2" Rain Cap

VAPOR FUEL SYSTEM ASSEMBLY

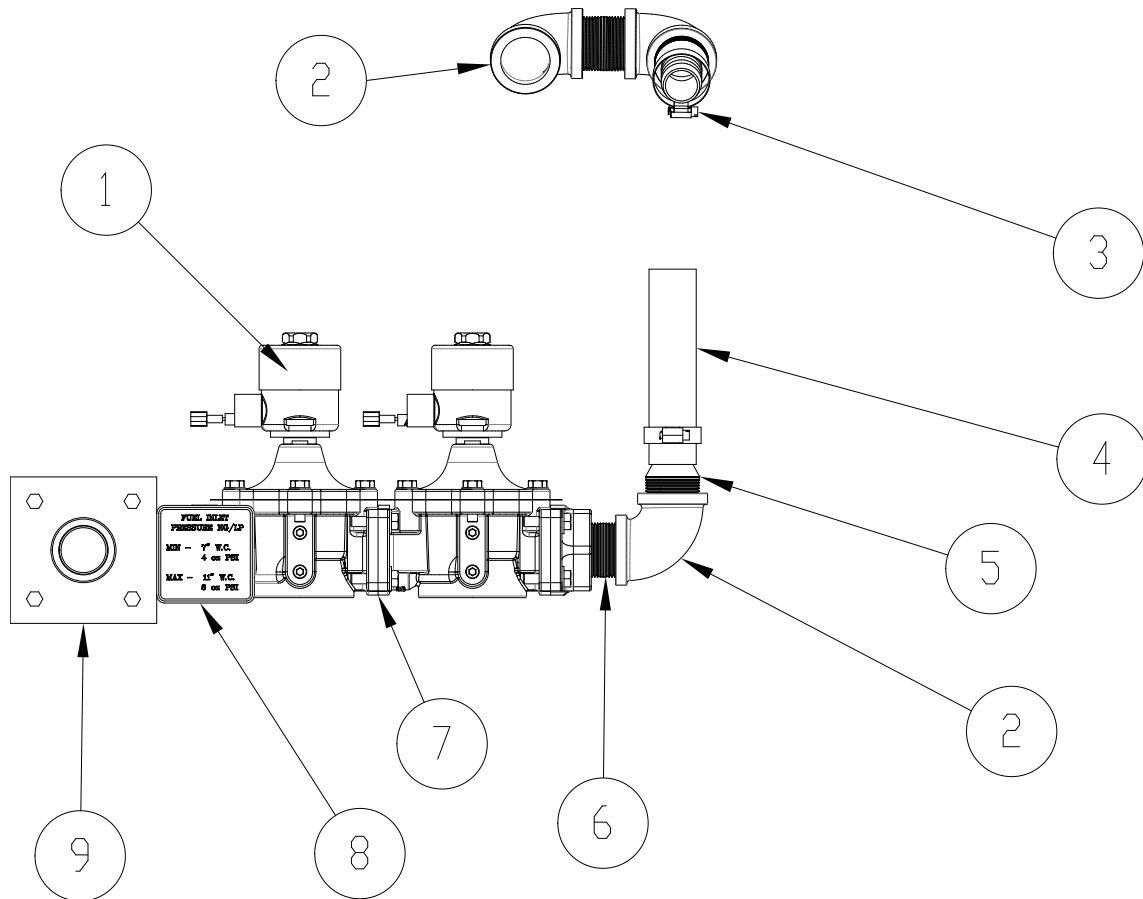

REF #	PART NUMBER	QTY	DESCRIPTION
1	42943-125	2	Solenoid
2	92042-000	4	1 1/4" 90° Pipe Elbow
3	81018-001	2	Hose Clamp
4	81103-000	6 FT	Fuel Hose
5	92388-008	2	Hose Fitting
6	22762-000	4	1 1/4" X 2" Pipe Nipple
7	42943-003	1	O-Ring
8	15210-010	1	Fuel Pressure Decal
9	99065-005	1	Inlet Weldment

AC WIRING MODIFICATIONS

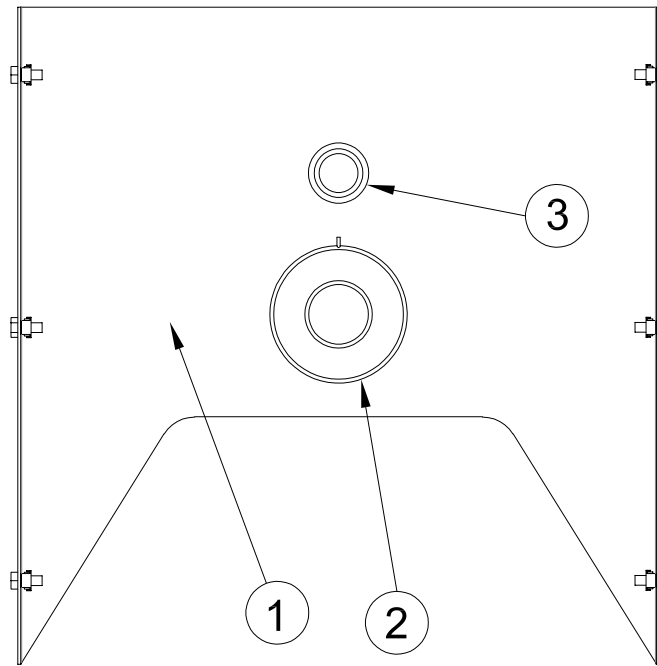

REF #	PART NUMBER	QTY	DESCRIPTION
1	64702-002	1	Front Panel
2	SEE TABLE	2 or 3	Current Transformer
3	62486-000	1	Grommet
NI	SEE TABLE	1	AC Harness

MODEL #	PART #	QTY	DESCRIPTION
ULPSS90-3/B ULPSS90-3/C	80124-008	2	500 to 5 Amp Current Transformer
ULPSS90-4/B & C ULPSS90-17/B & C ULPSS90-18/B & C	80124-008	3	500 to 5 Amp Current Transformer

MODEL #	PART #	QTY	DESCRIPTION
ULPSS90-3/B ULPSS90-3/C	99347-014	1	AC Harness
ULPSS90-4/B & C ULPSS90-17/B & C ULPSS90-18/B & C	99347-015	1	AC Harness

HOUSING ASSEMBLY

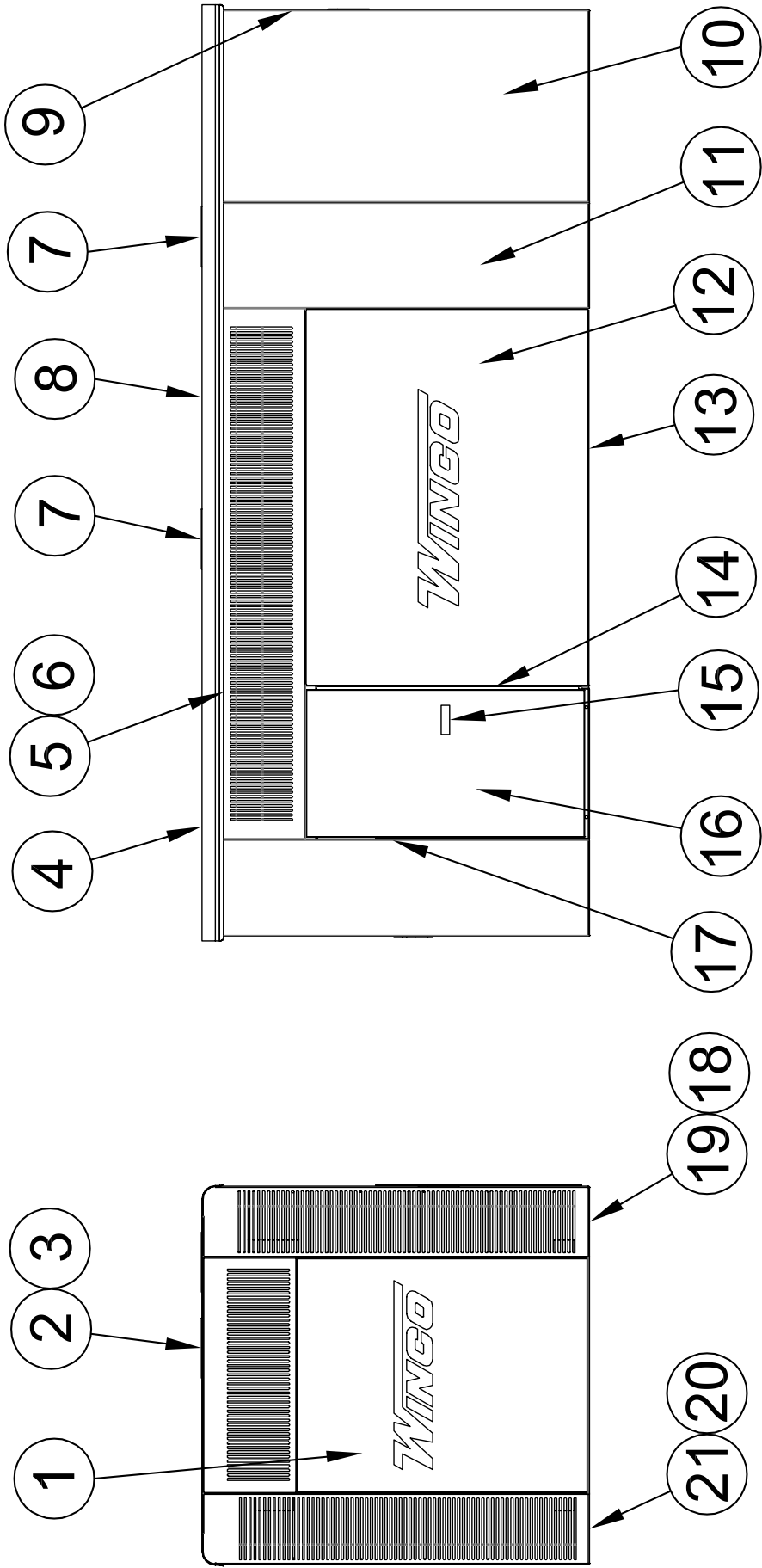

REF #	PART NUMBER	QTY	DESCRIPTION
1	99100-091	1	Rear Center Panel
2	99100-090	1	Rear Sill
3	99378-090	1	Rear Sill Baffle
4	99515-090	1	Roof
5	99078-091	1	Right Side Sill
6	99378-094	1	Right Side Sill Baffle
7	99515-011	2	Roof Access Cover
8	99225-005	3	Roof Support
9	99378-095	1	Exhaust (CAC) Baffle
10	99071-038	1	Housing Front
11	99071-037	1	Radiator Housing
12	99100-093	1	Right Side Panel
13	65000-003	8	Thumb Screw
14	99333-017	1	Door Stop
15	95229-005	1	Door Latch
16	15680-057	1	Door
17	98375-090	1	Hinge
18	99067-091	1	Right Rear Corner Post
19	99378-092	1	Right Rear Baffle
20	99067-090	1	Left Rear Corner Post
21	99378-091	1	Left Rear Baffle
NI	99078-090	1	Left Side Sill
NI	99378-093	1	Left Side Sill Baffle
NI	99100-094	1	Left Side Large Panel
NI	99100-092	1	Left Side Rear Small Panel
NI	99060-008	4	Lifting Eye Cover Plate
NI	91683-000	8	¼ Turn Rect. Clip Nut
NI	91682-002	8	¼ Turn Bail Style Stud
NI	91684-000	8	¼ Turn Split Ring Retainer
NI	62912-002	12 FT	3/8" Foam Strip
NI	62912-000	4 FT	½" Foam Strip
NI	92421-000	12 FT	1.5" X 1.5" Foam Strip
NI	Not Illustrated		

ACOUSTIC FOAM PIECES

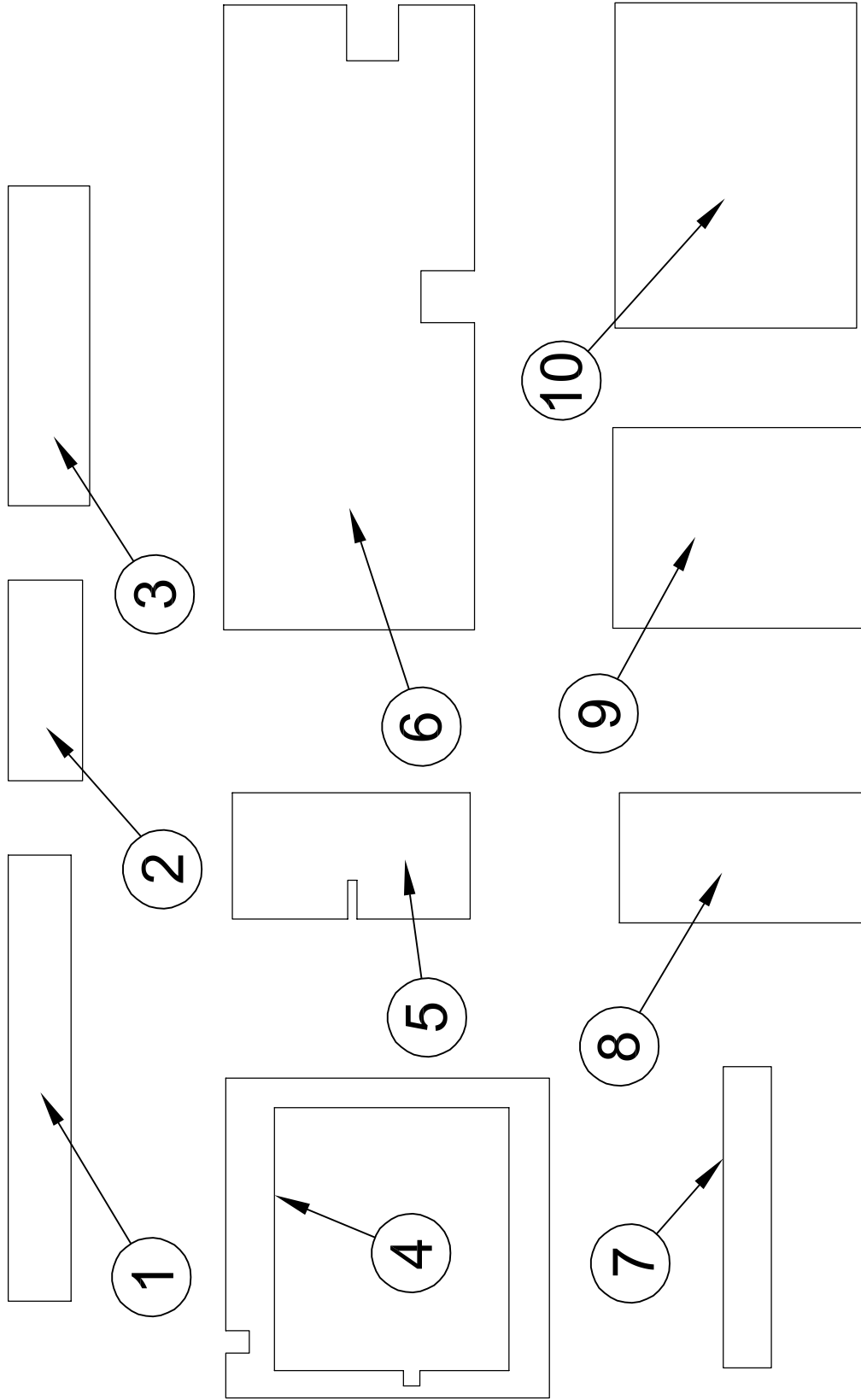

ACOUSTIC FOAM PIECES

REF #	PART NUMBER	QTY	DESCRIPTION
1	99393-126S	2	Side Sill Foam
2	99393-130S	1	Rear Center Baffle Foam
3	99393-124S	2	Radiator Side Foam
4	99393-123S	1	Radiator Housing Foam
5	99393-127S	1	Door Foam
6	99393-122S	1	Roof Foam
7	99393-128S	2	Rear Baffle Foam
8	99393-131S	1	Rear Side Panel Foam
9	99393-125S	1	Rear Center Foam
10	99393-129S	2	Side Panel Foam

ULPSS90-3/B & C

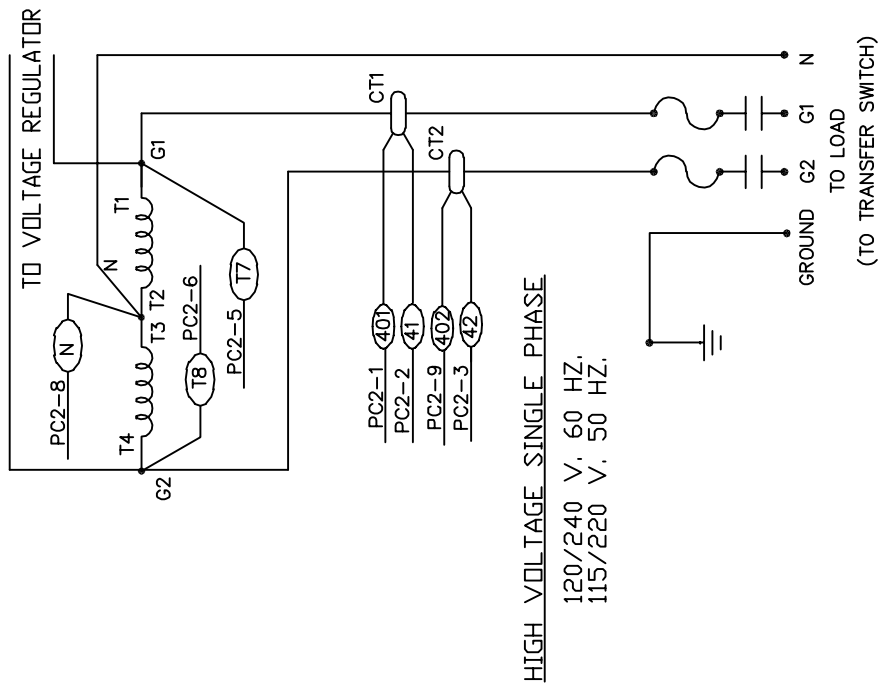

AC WIRING SCHEMATICS

ULPSS90-18/B & C

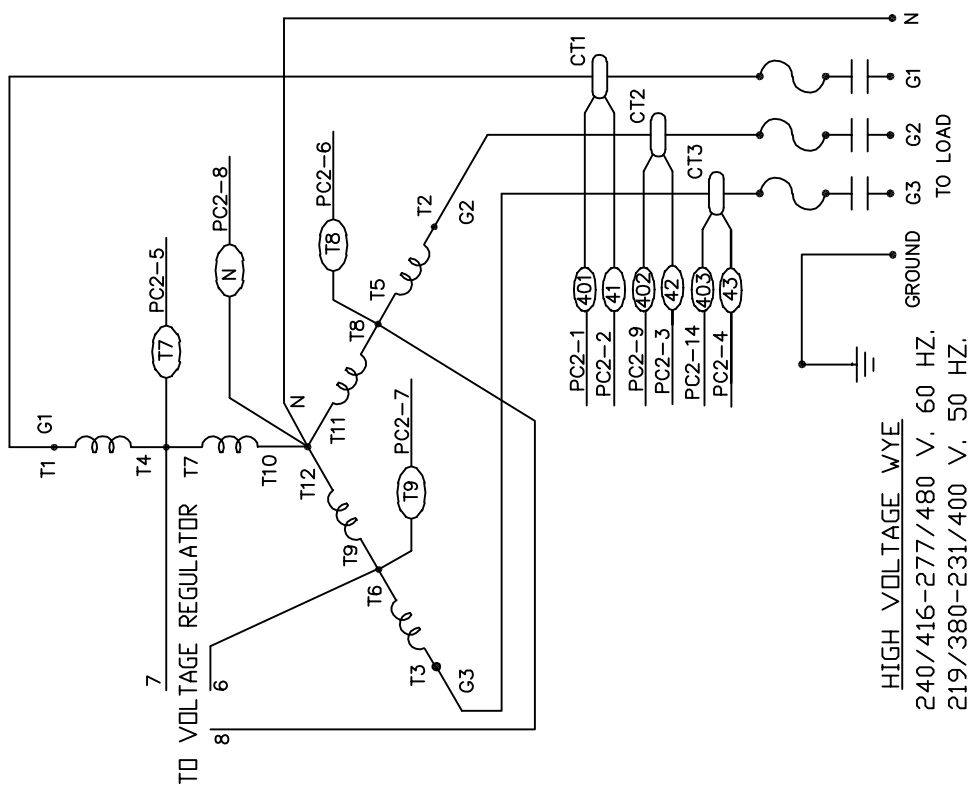

ULPSS90-4/B & C

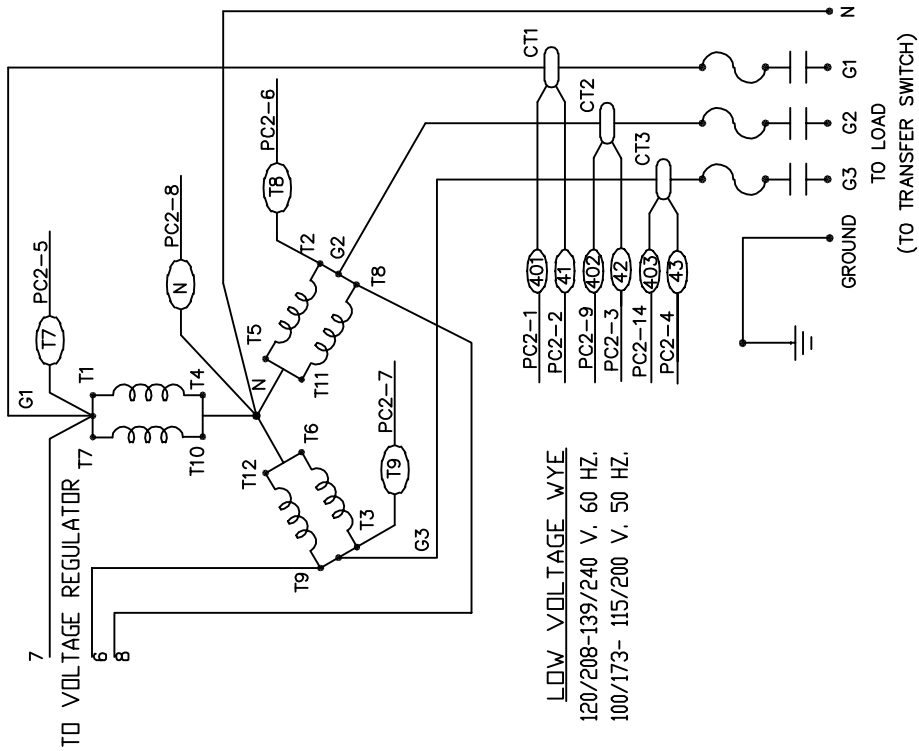

ULPSS90-17/B & C

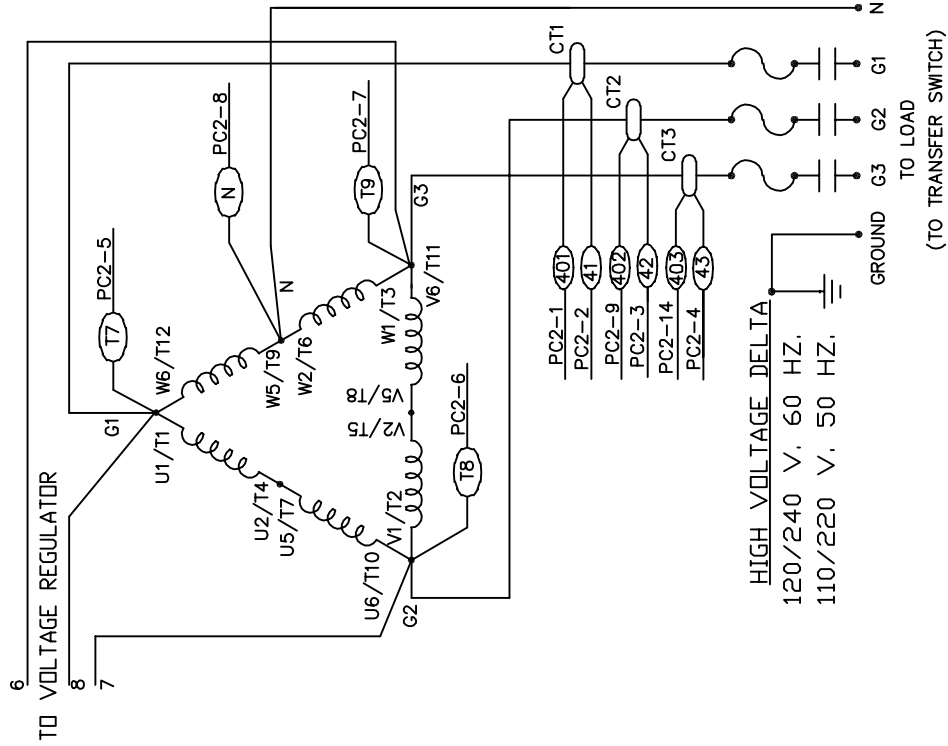

DC WIRING SCHEMATIC DSE7110

TO A.C. POWER GENERATOR

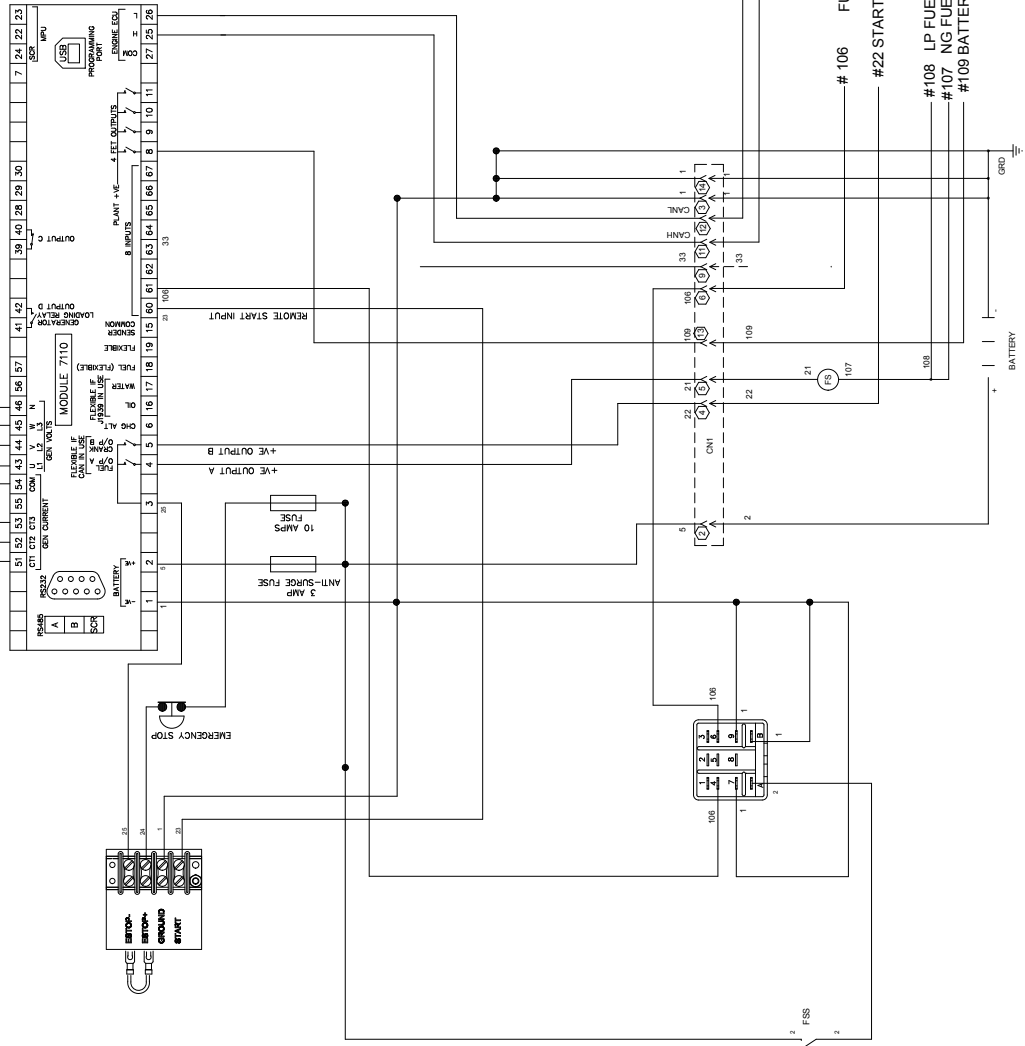
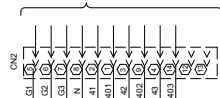

LEGEND

- CN1 16 PIN (LARGE CONNECTOR)
- ENGINE CONTROL HARNESS
- CN2 14 PIN GENERATOR HARNESS
- AC CONTROL HARNESS
- CANH CANBUS HIGH
- CANL CANBUS LOW
- ESS EMERGENCY STOP SWITCH
- GRD GROUND (CHASSIS OR FRAME)
- LCL OPTIONAL LOW COOLANT LEVEL PROBE
- FS FUEL SOLENOIDS
- FSS FUEL SELECT SWITCH

- GROUND
- AUX PWN 5
- CAN -
- CAN +
- AUX ANA PUD 1
- GOV 1
- AUX ANA PUD3
- AUX ANA PUD2
- FUEL SELECT
- MIL
- START COMMAND
- AUX PWN 4
- RELAY POWER
- LOCKOFF (SECONDARY)
- LOCKOFF (PRIMARY)
- VSW

- #1 BAT NEG
- NOT USED
- CANL
- CANH
- NOT USED
- NOT USED
- NOT USED
- NOT USED
- FUEL SELECT
- NOT USED
- #22 START COMMAND
- NOT USED
- NOT USED
- #108 LP FUEL SOLENOID
- #107 NG FUEL SOLENOID
- #109 BATTERY POSITIVE

DC WIRING SCHEMATIC DSE7310

