



ILLUSTRATED PARTS LIST

ULPSS60-3/B & /C

ULPSS60-4/B & /C

ULPSS60-17/B & /C

ULPSS60-18/B & /C

**WITH DSE 7110 & DSE7310
ENGINE CONTROL**

**225 S. CORDOVA AVE.
LECENTER, MN 56057
507-357-6821
SERVICE DEPT.
507-357-6831
wincogen.com**

GENERATOR ASSEMBLY

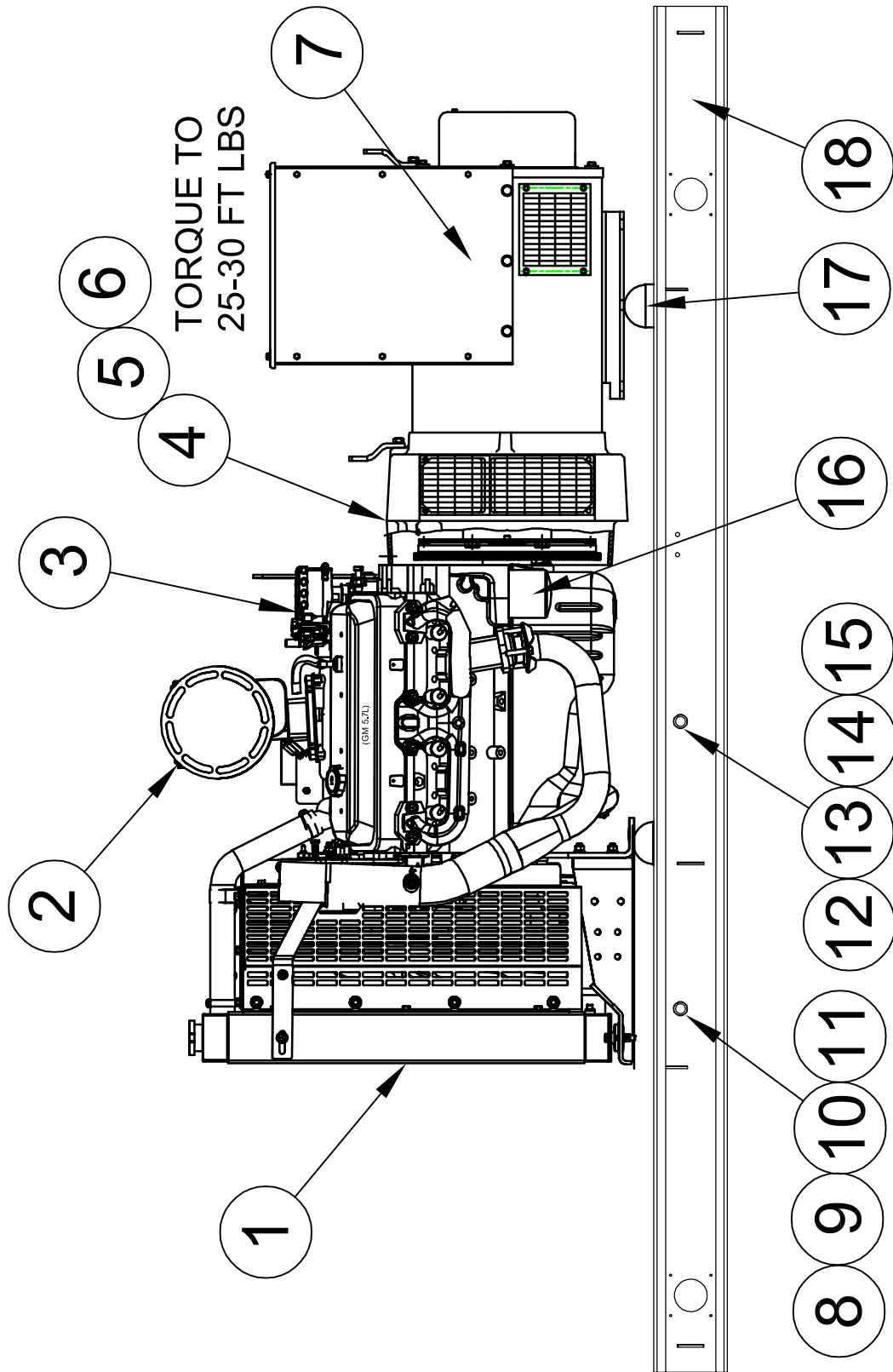

| REF # | PART NUMBER | QTY | DESCRIPTION |
|-------|------------------|------|----------------------------|
| 1 | Reference | 1* | Radiator |
| 2 | F1-15 | 1** | Air Filter |
| 3 | 351987-3 | 1 | Engine GM 5.7 L |
| 4 | 96000-004 | 12 | 3/8-16 X 1 1/2" Bolt |
| 5 | 96000-002 | 8 | 3/8-16 X 2" Bolt |
| 6 | 481-001 | 20 | 3/8" Lock Washer |
| 7 | SEE TABLE | 1 | Generator, Stamford Newage |
| 8 | 93824-003 | 1 | Petcock Valve |
| 9 | 55505-000 | 1 FT | 3/8" Hose |
| 10 | 94319-008 | 2 | Hose Fitting |
| 11 | 93084-000 | 2 | 1/2" Pipe Plug |
| 12 | 98906-009 | 1 | Oil Drain Valve |
| 13 | 99778-000 | 1 | Adapter |
| 14 | 55505-000 | 20" | 3/8" Hose |
| 15 | 62625-001 | 15" | Insulated Sleaving |
| 16 | PF454 | 1*** | Oil Filter, AC Delco |
| 17 | 98956-001 | 4 | Shock Mount |
| 18 | 99309-061 | 1 | Base Assembly |
| NI | 99317-001 | 1 | Battery Tray |
| NI | 53220-013 | 1 | Negative (-) Battery Cable |
| NI | 53220-058 | 1 | Positive (+) Battery Cable |
| NI | 72036-015 | 1 | Battery Charger |
| NI | 350818-2 | 1 | Voltage Regulator AS440 UL |
| NI | 99420-023 | 1 | GM DC Harness |
| NI | R42LTS or R44LTS | 8*** | Spark Plug |
| NI | Not Illustrated | | |
| * | GM Part | | |
| ** | Impco Part # | | |
| *** | AD Delco Part # | | |

| MODEL # | STAMFORD NEWAGE MODEL # | WINCO PART # |
|---|----------------------------|--------------|
| ULPSS60-3/B ULPSS60-3/C | UCI224F1J 4-LEAD | 351928-41 |
| ULPSS60-4/B & C ULPSS60-17/B & C ULPSS60-18/B & C | UCI224F1L 12-LEAD | 351928-4 |

BLOCK HEATER ASSEMBLY

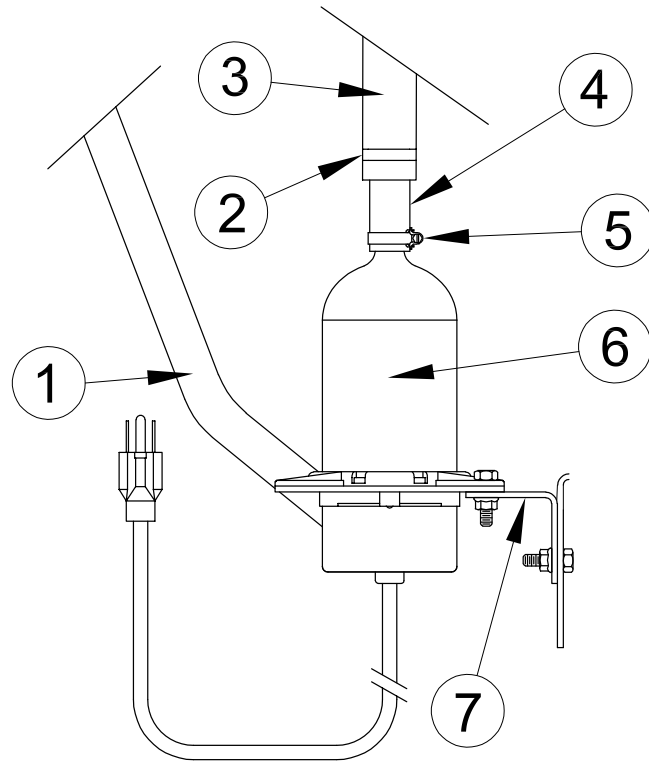

| REF # | PART NUMBER | QTY | DESCRIPTION |
|-------|-----------------|------|------------------------|
| 1 | 93689-001 | 32" | 5/8" Hose |
| 2 | Reference | 4 | Zip Tie |
| 3 | 62625-002 | 3 FT | Insulated Sleeving |
| 4 | 93689-001 | 26" | 5/8" Hose |
| 5 | 81018-005 | 4 | Hose Clamp |
| 6 | 80781-003 | 1 | 1000W 120V Tank Heater |
| 7 | Reference | 1 | Mounting Bracket |
| NI | 62625-004 | 2 FT | Heat Sleeve |
| NI | Not Illustrated | | |

ENGINE CONTROL ASSEMBLY ULPSS60/B WITH DSE 7110

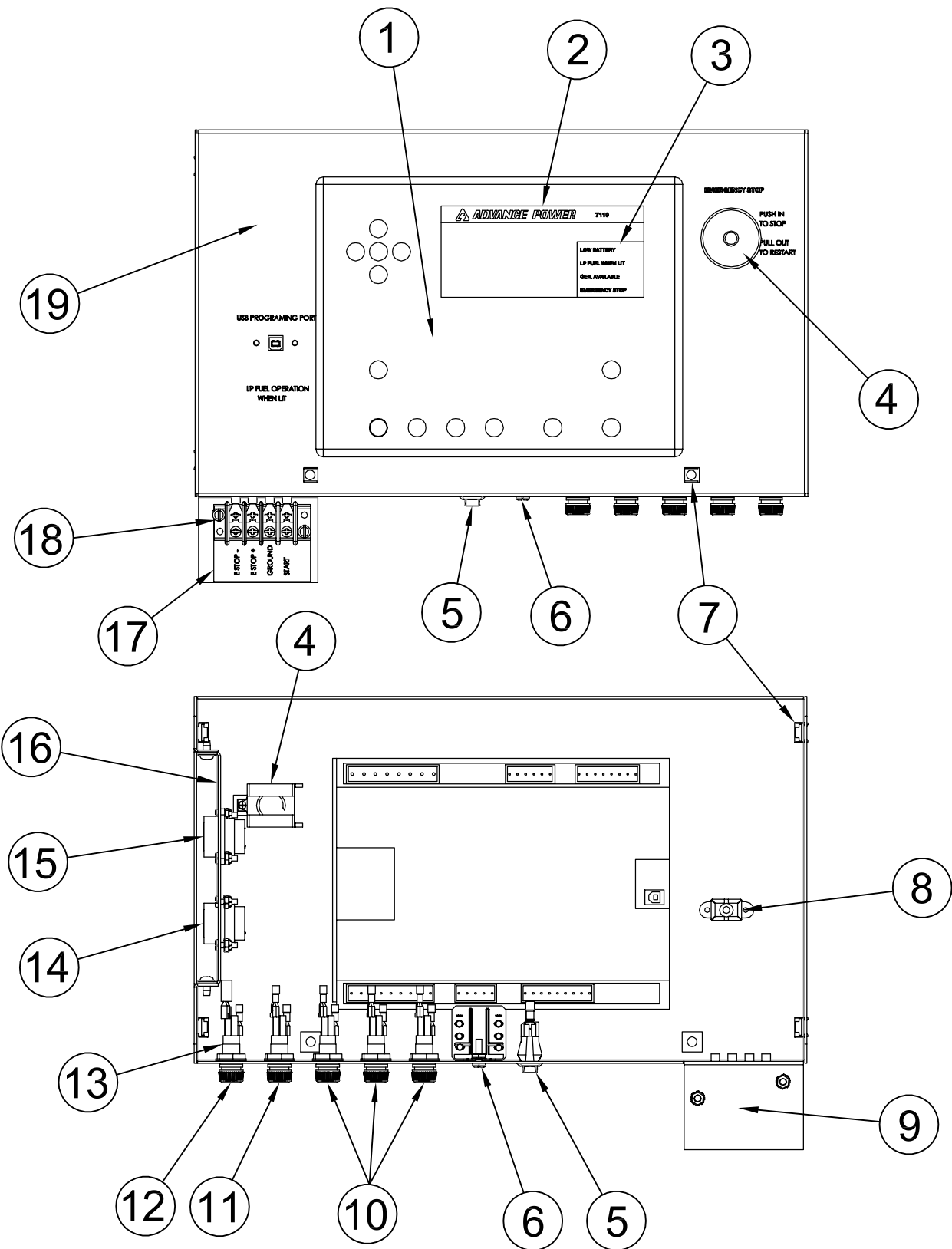

| REF # | PART NUMBER | QTY | DESCRIPTION |
|-------|-----------------|-----|-------------------------|
| 1 | 351112-3 | 1 | DSE 7110 Controller |
| 2 | 1660-001 | 1 | Advance Power Insert |
| 3 | 16601-003 | 1 | LED Legend Insert |
| 4 | 99783-002 | 1 | Emergency Stop Switch |
| 5 | 64089-000 | 1 | SPST Rocker Switch |
| 6 | 59944-017 | 1 | DPDT Relay 12VDC 10 Amp |
| 7 | 92495-000 | 6 | Retainer Nut |
| 8 | 92844-005 | 1 | USB Cable |
| 9 | 99826-196 | 1 | DC Box |
| 10 | 95064-002 | 3 | 2 Amp Fuse |
| 11 | 95064-000 | 1 | 3 Amp Fuse |
| 12 | 95064-006 | 1 | 10 Amp Fuse |
| 13 | 2489-001 | 5 | Fuse Holder |
| 14 | 96925-006 | 1 | 16 Pin Connector |
| 15 | 96925-002 | 1 | 14 Pin Connector |
| 16 | 351900-11 | 1 | Connector Plate |
| 17 | 64576-019 | 1 | Remote Terminal Decal |
| 18 | 80623-008 | 1 | 4 Point Terminal Block |
| 19 | 99055-037 | 1 | Control Panel |
| NI | 99783-002 | 1 | E Stop Contact |
| NI | Not Illustrated | | |

ENGINE CONTROL ASSEMBLY ULPSS60/C WITH DSE 7310

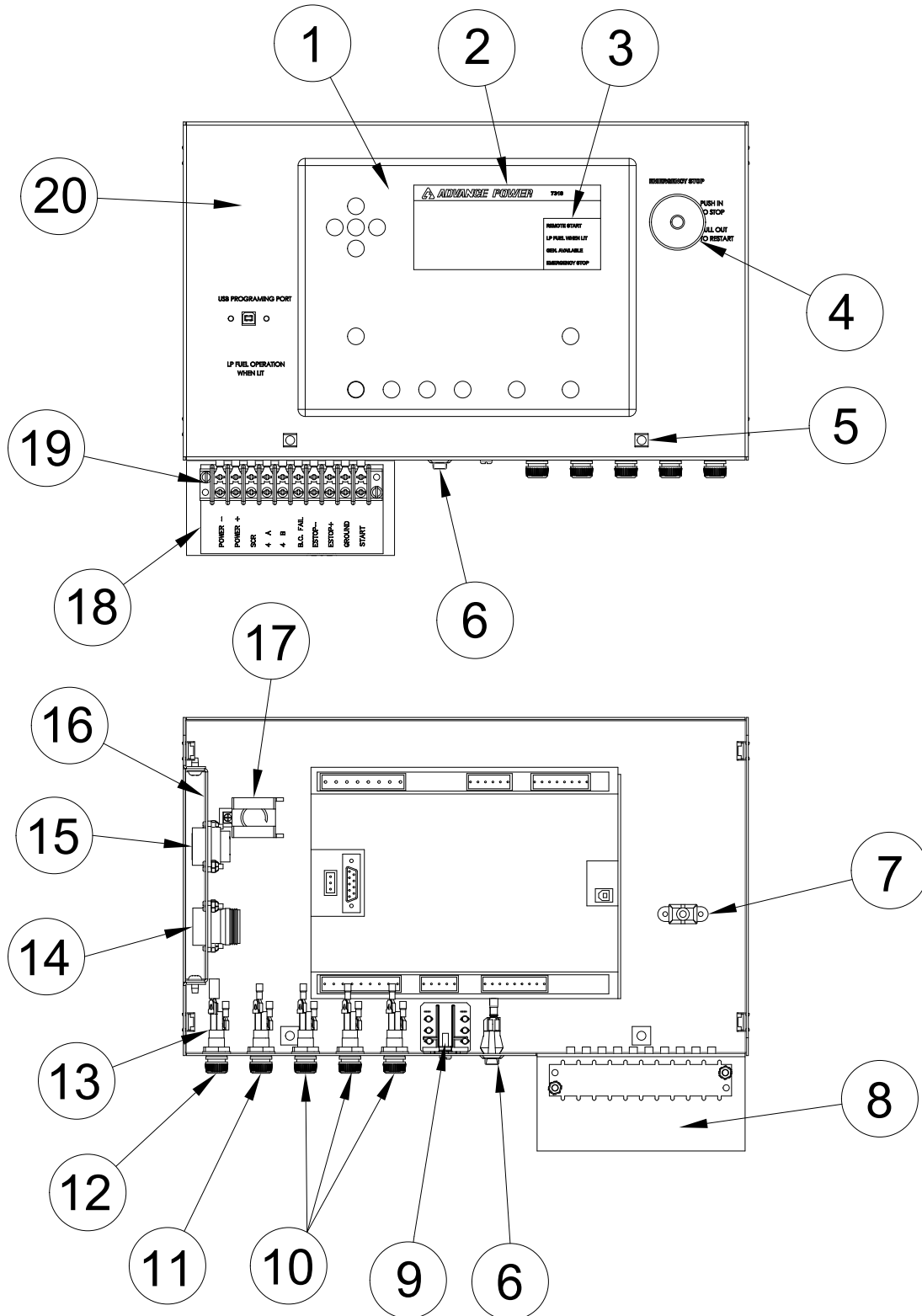

| REF # | PART NUMBER | QTY | DESCRIPTION |
|-------|-------------|-----|-------------------------|
| 1 | 351112-4 | 1 | DSE 7310 Controller |
| 2 | 1660-001 | 1 | Advance Power Insert |
| 3 | 16601-001 | 1 | LED Legend Insert |
| 4 | 99783-001 | 1 | Emergency Stop Switch |
| 5 | 92495-000 | 6 | Retainer Nut |
| 6 | 64089-000 | 1 | SPST Rocker Switch |
| 7 | 92844-005 | 1 | USB Cable |
| 8 | 99826-196 | 1 | DC Box |
| 9 | 59944-017 | 1 | DPDT Relay 12VDC 10 Amp |
| 10 | 95064-002 | 3 | 2 Amp Fuse |
| 11 | 95064-000 | 1 | 3 Amp Fuse |
| 12 | 95064-006 | 1 | 10 Amp Fuse |
| 13 | 2489-001 | 5 | Fuse Holder |
| 14 | 96925-006 | 1 | 16 Pin Connector |
| 15 | 96925-002 | 1 | 14 Pin Connector |
| 16 | 351900-11 | 1 | Connector Plate |
| 17 | 99783-002 | 1 | E Stop Contact |
| 18 | 64576-019 | 1 | Remote Terminal Decal |
| 19 | 80623-006 | 1 | 10 Point Terminal Block |
| 20 | 99055-038 | 1 | Control Panel |

DECALS

| REF # | PART NUMBER | QTY | DESCRIPTION |
|-------|-------------|-----|---------------------------|
| NI | 97813-000 | 3 | Warning Auto Start Decal |
| NI | 63941-001 | 1 | Hot Surface Decal |
| NI | 15209-000 | 1 | UL Decal Set |
| NI | 15209-100 | 1 | French UL Decal Set |
| NI | 16502-001 | 1 | AC Disconnect Decal |
| NI | 63941-003 | 1 | Battery Compartment Decal |
| NI | 63941-005 | 1 | Receptacle Caution Decal |
| NI | 15210-010 | 1 | UL Fuel System Decal |

CONTROL CABINET ASSEMBLY

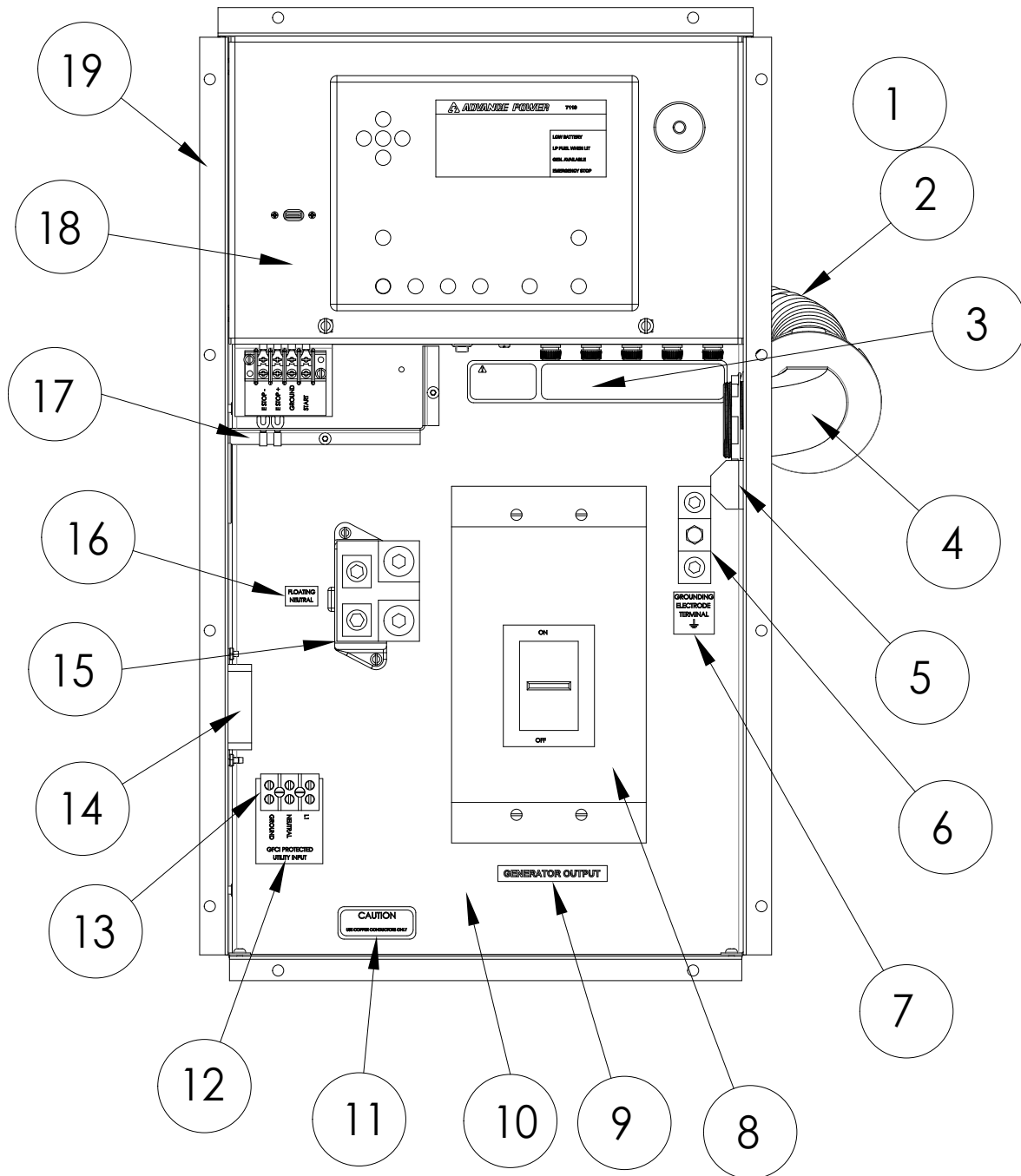

| REF # | PART NUMBER | QTY | DESCRIPTION |
|-------|-----------------|-----|--------------------------------|
| 1 | 16522-000 | 1 | 2" Straight Conduit Fitting |
| 2 | 16523-000 | 18" | 2" Flexible Conduit |
| 3 | 63941-007 | 1 | Fuse ID Warning Decal |
| 4 | 16522-001 | 1 | 2" 90° Conduit Fitting |
| 5 | 99826-194 | 1 | Door Latch |
| 6 | 58060-000 | 2 | Ground Lug |
| 7 | 16499-000 | 1 | Grounding Decal |
| 8 | SEE TABLE | 1 | Circuit Breaker |
| 9 | 64576-009 | 1 | Generator Output Decal |
| 10 | SEE TABLE | 1 | Circuit Breaker Mounting Panel |
| 11 | 16503-000 | 1 | Copper Conductor Decal |
| 12 | 64576-006 | 1 | GFCI Protected Decal |
| 13 | 51795-000 | 1 | 3 Point Terminal Block |
| 14 | 24749-000 | 1 | Duplex Receptacle |
| 15 | 350124-2 | 1 | Neutral Block |
| 16 | 16501-000 | 1 | Floating Neutral Decal |
| 17 | 99826-192 | 1 | DC Box |
| 18 | SEE TABLE | 1 | Engine Control Assembly |
| 19 | 99826-160 | 1 | Circuit Breaker Cabinet |
| NI | SEE TABLE | 1 | Circuit Breaker Cover Panel |
| NI | Not Illustrated | | |

| MODEL # | PART # | DESCRIPTION |
|------------------------------|-------------------------------------|--|
| ULPSS60-3/B ULPSS60-3/C | 81094-707 99826-162 99826-163 | 250 Amp 240 Volt 2-Pole Breaker Circuit Breaker Mounting Panel Circuit Breaker Cover Panel |
| ULPSS60-4/B ULPSS60-4/C | 81096-005 99826-165 99826-166 | 200 Amp 240 Volt 3-Pole Breaker Circuit Breaker Mounting Panel Circuit Breaker Cover Panel |
| ULPSS60-17/B ULPSS60-17/C | 81096-004 99826-165 99826-166 | 175 Amp 240 Volt 3-Pole Breaker Circuit Breaker Mounting Panel Circuit Breaker Cover Panel |
| ULPSS60-18/B ULPSS60-18/C | 81098-028 99826-167 99826-168 | 90 Amp 600 Volt 3-Pole Breaker Circuit Breaker Mounting Panel Circuit Breaker Cover Panel |

EXHAUST ASSEMBLY

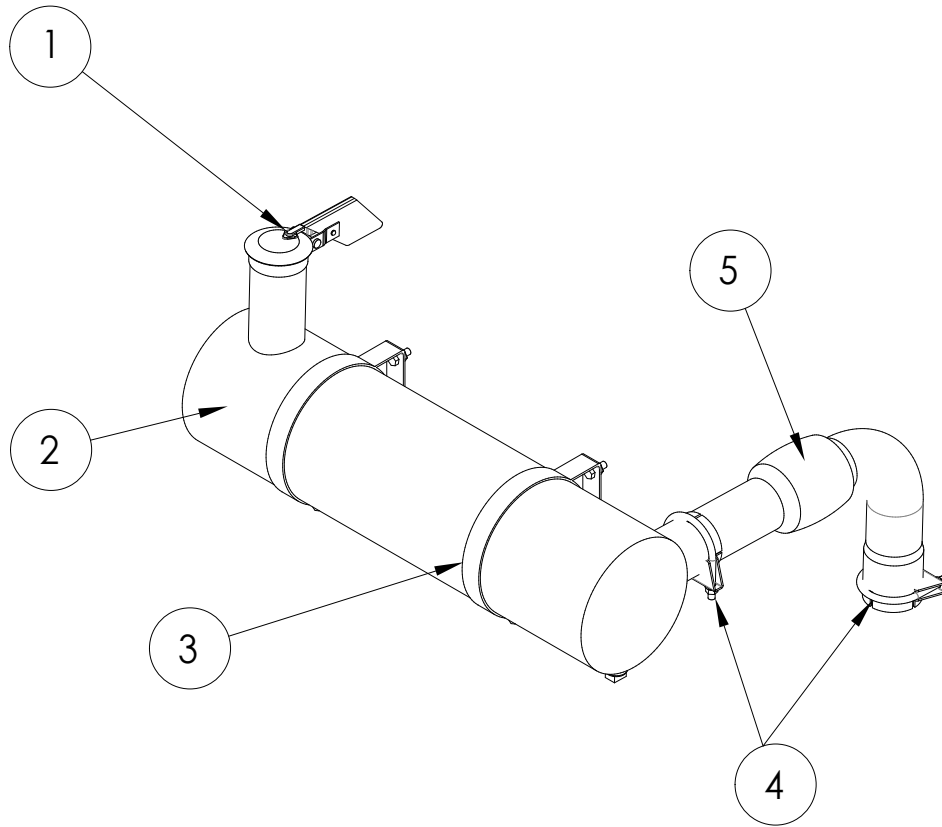

| REF # | PART NUMBER | QTY | DESCRIPTION |
|-------|-------------|-----|---------------------|
| 1 | 53111-008 | 1 | 3" Rain Cap |
| 2 | 80519-013 | 1 | Muffler |
| 3 | 350264-7 | 2 | 8" Exhaust Band |
| 4 | 93489-001 | 2 | 3 3/8" Muffer Clamp |
| 5 | 99502-011 | 1 | Exhaust Flex |

VAPOR FUEL SYSTEM ASSEMBLY

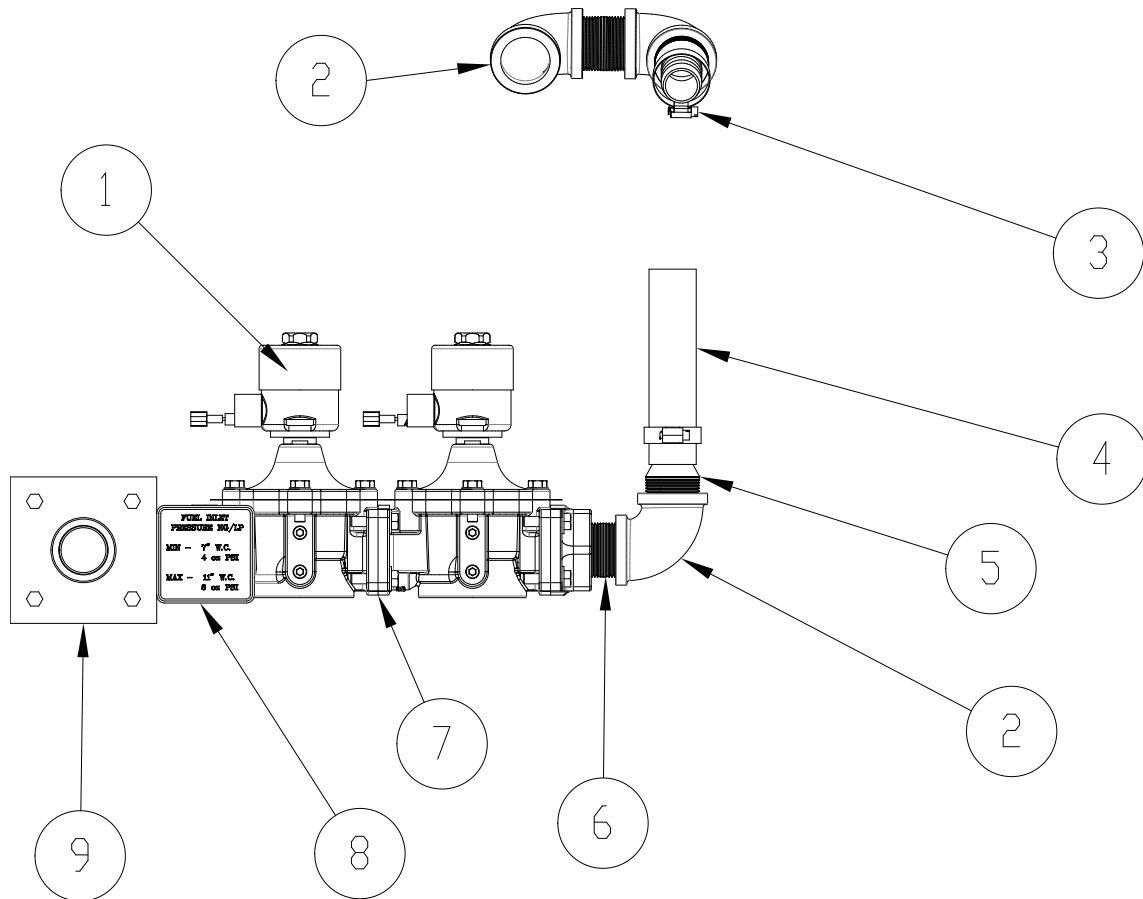

| REF # | PART NUMBER | QTY | DESCRIPTION |
|-------|-------------|------|-------------------------|
| 1 | 42943-125 | 2 | Solenoid |
| 2 | 92042-000 | 4 | 1 1/4" 90° Pipe Elbow |
| 3 | 81018-001 | 2 | Hose Clamp |
| 4 | 81103-000 | 6 FT | Fuel Hose |
| 5 | 92388-008 | 2 | Hose Fitting |
| 6 | 22762-000 | 4 | 1 1/4" X 2" Pipe Nipple |
| 7 | 42943-003 | 1 | O-Ring |
| 8 | 15210-010 | 1 | Fuel Pressure Decal |
| 9 | 99065-005 | 1 | Inlet Weldment |

AC WIRING MODIFICATIONS

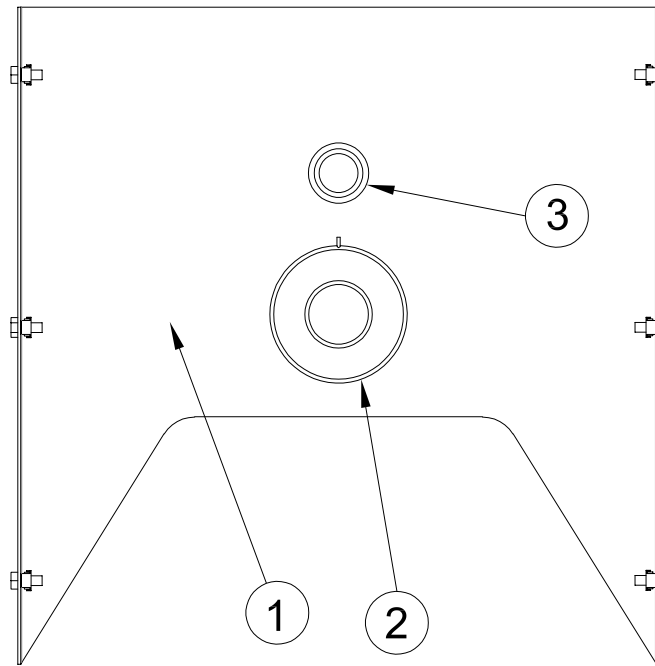

| REF # | PART NUMBER | QTY | DESCRIPTION |
|-------|-------------|--------|---------------------|
| 1 | 64702-000 | 1 | Front Panel |
| 2 | SEE TABLE | 2 or 3 | Current Transformer |
| 3 | 62486-000 | 1 | Grommet |
| NI | SEE TABLE | 1 | AC Harness |

| MODEL # | PART # | QTY | DESCRIPTION |
|---|-----------|-----|--|
| ULPSS60-3/B ULPSS60-3/C | 80124-008 | 2 | 500 to 5 Amp Current Transformer |
| ULPSS60-4/B & C ULPSS60-17/B & C ULPSS60-18/B & C | 80124-008 | 3 | 500 to 5 Amp Current Transformer |

| MODEL # | PART # | QTY | DESCRIPTION |
|---|-----------|-----|-------------|
| ULPSS60-3/B ULPSS60-3/C | 99347-014 | 1 | AC Harness |
| ULPSS60-4/B & C ULPSS60-17/B & C ULPSS60-18/B & C | 99347-015 | 1 | AC Harness |

HOUSING ASSEMBLY

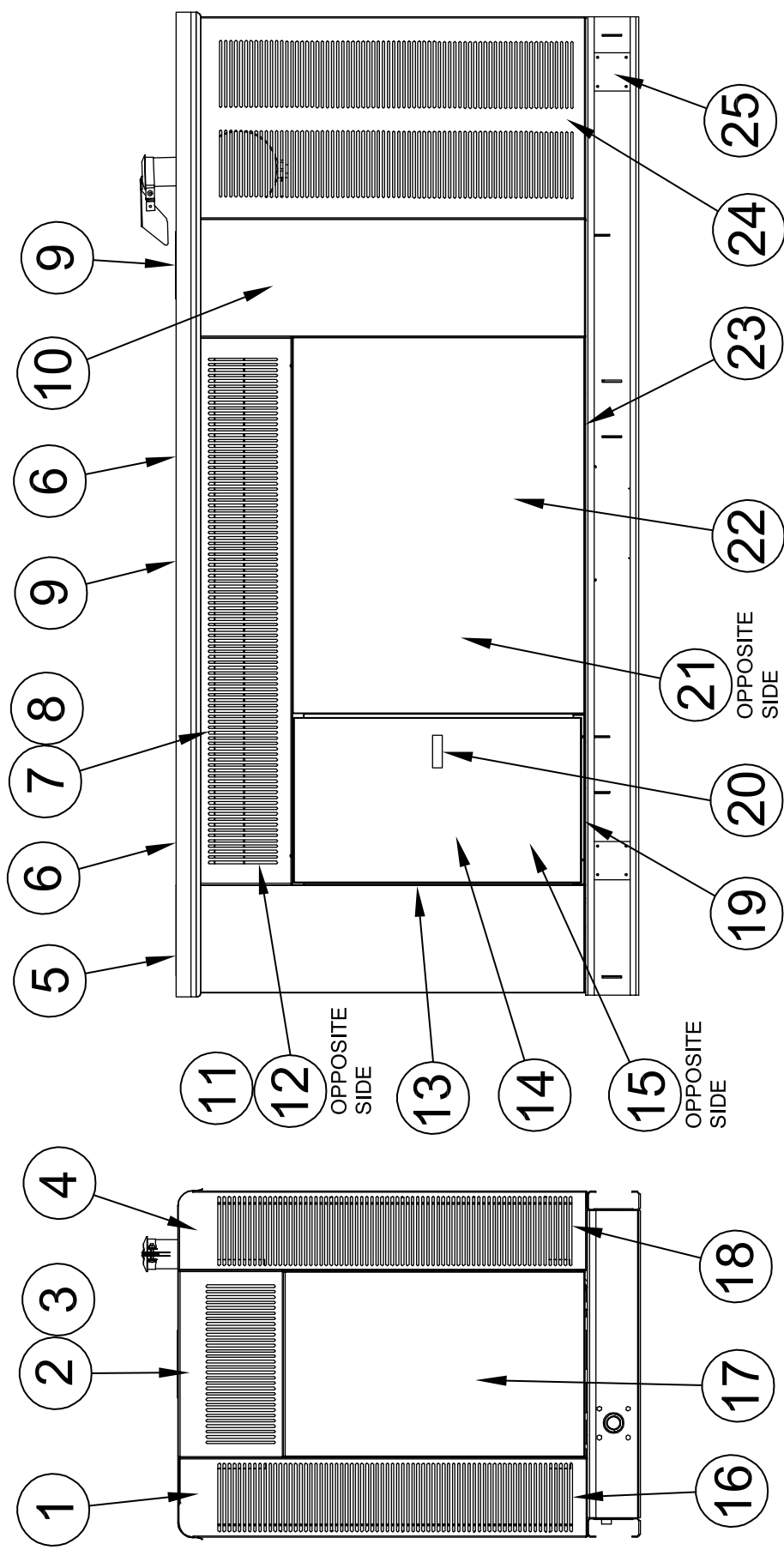

| REF # | PART NUMBER | QTY | DESCRIPTION |
|-------|-------------|-----|--------------------------|
| 1 | 99067-030 | 1 | Left Rear Corner Panel |
| 2 | 99100-062 | 1 | Rear Sill |
| 3 | 99378-054 | 1 | Rear Sill Baffle |
| 4 | 99067-029 | 1 | Right Rear Corner Panel |
| 5 | 99515-008 | 1 | Roof |
| 6 | 99225-003 | 2 | Roof Support |
| 7 | 99078-061 | 1 | Right Side Sill |
| 8 | 99378-056 | 1 | Right Side Sill Baffle |
| 9 | 99515-011 | 2 | Roof Cover Plate |
| 10 | 99071-034 | 1 | Radiator Housing |
| 11 | 99078-060 | 1 | Left Side Sill |
| 12 | 99378-055 | 1 | Left Side Sill Baffle |
| 13 | 98375-018 | 1 | Hinge |
| 14 | 15680-055 | 1 | Right Side Door |
| 15 | 99100-066 | 1 | Left Side Rear Panel |
| 16 | 99378-057 | 1 | Left Rear Corner Baffle |
| 17 | 99100-063 | 1 | Rear Center Panel |
| 18 | 99378-058 | 1 | Right Rear Corner Baffle |
| 19 | 99333-015 | 1 | Door Stop |
| 20 | 95229-005 | 1 | Door Latch |
| 21 | 99100-065 | 1 | Left Side Panel |
| 22 | 99100-064 | 1 | Right Side Panel |
| 23 | 65000-003 | 8 | Thumb Screws |
| 24 | 99071-028 | 1 | Front Housing |
| 25 | 99060-008 | 4 | Lifting Hole Cover Plate |

ACOUSTIC FOAM PIECES

| REF # | PART NUMBER | QTY | DESCRIPTION |
|-------|-------------|-----|------------------------|
| 1 | 99393-406 | 2 | Side Sill Foam |
| 2 | 99393-409 | 1 | Radiator Housing Foam |
| 3 | 99393-405 | 2 | Rear Baffle Foam |
| 4 | 99393-403 | 1 | Back Center Foam |
| 5 | 99393-408 | 2 | Front Side Foam |
| 6 | 99393-407 | 2 | Side Panel Foam |
| 7 | 99393-401 | 1 | Door Foam |
| 8 | 99393-402 | 1 | Rear Center Panel Foam |
| 9 | 99393-404 | 1 | Back Top Foam |
| 10 | 99393-410 | 1 | Roof Foam |

ACOUSTIC FOAM PIECES

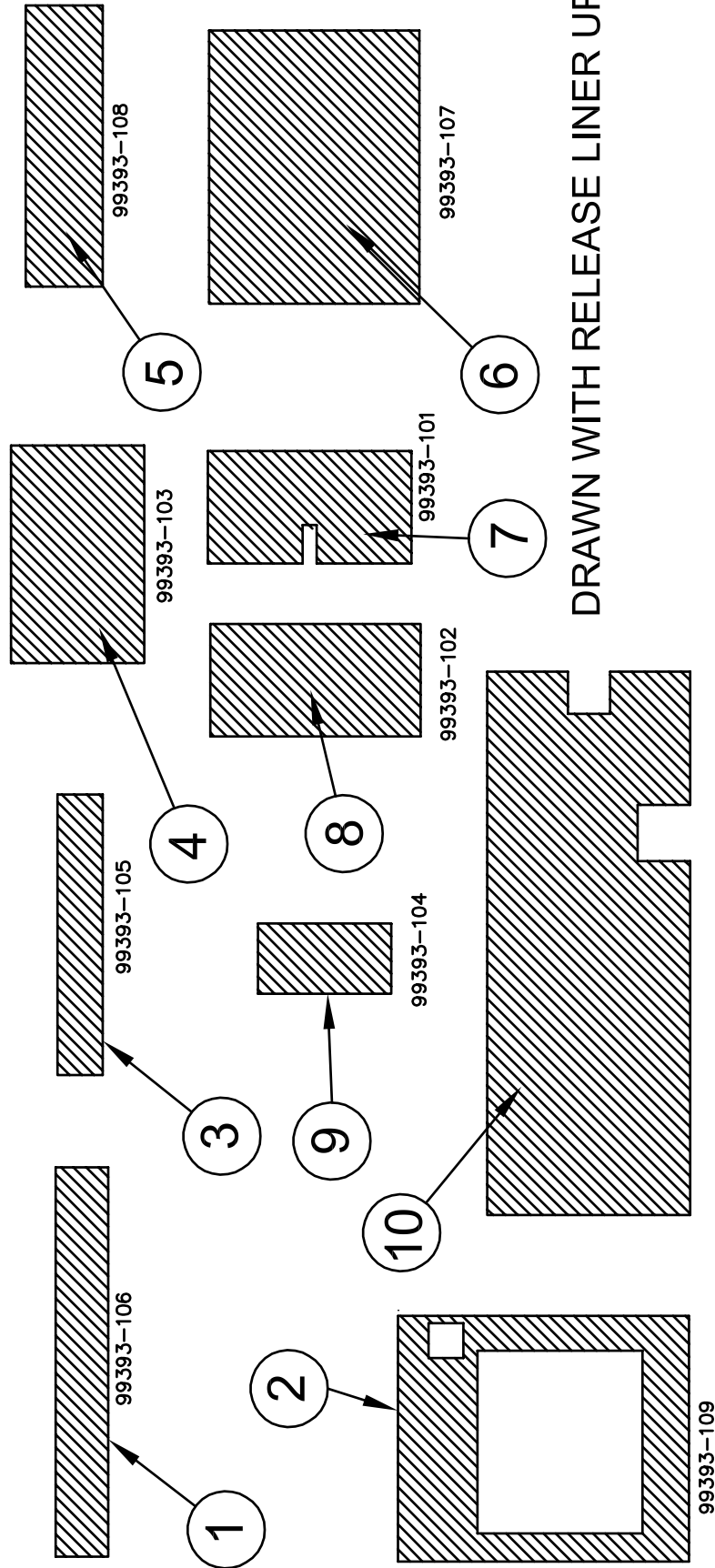

DRAWN WITH RELEASE LINER UP.

ULPSS60-3/B & C

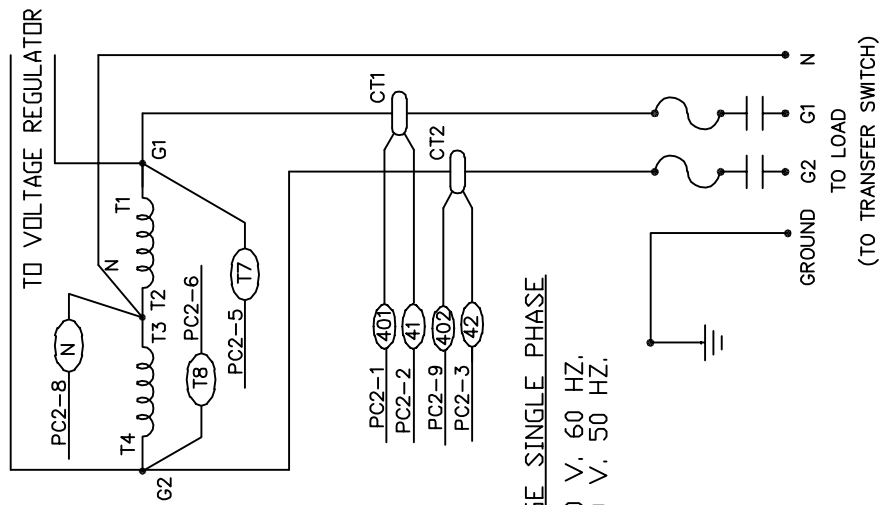

HIGH VOLTAGE SINGLE PHASE

120/240 V, 60 HZ.
115/220 V, 50 HZ.

GROUND
G1 G2 G3
TO LOAD
(TO TRANSFER SWITCH)

AC WIRING SCHEMATICS

ULPSS60-18/B & C

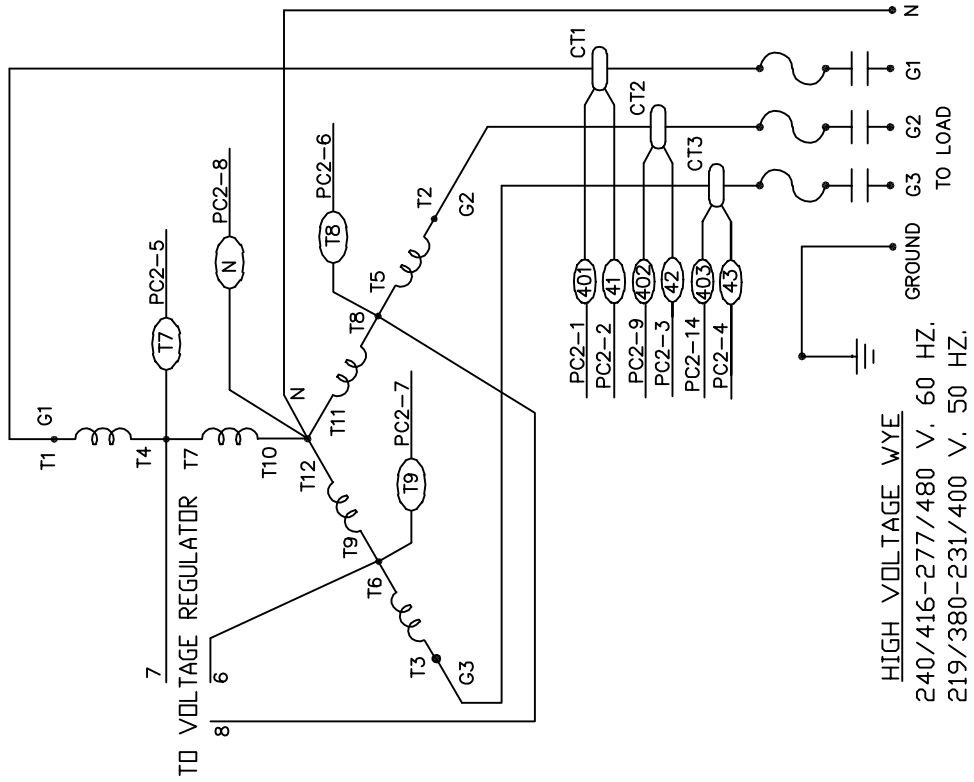

HIGH VOLTAGE WYE

240/416-277/480 V, 60 HZ.
219/380-231/400 V, 50 HZ.

GROUND
G1 G2 G3
TO LOAD

ULPSS60-4/B & C

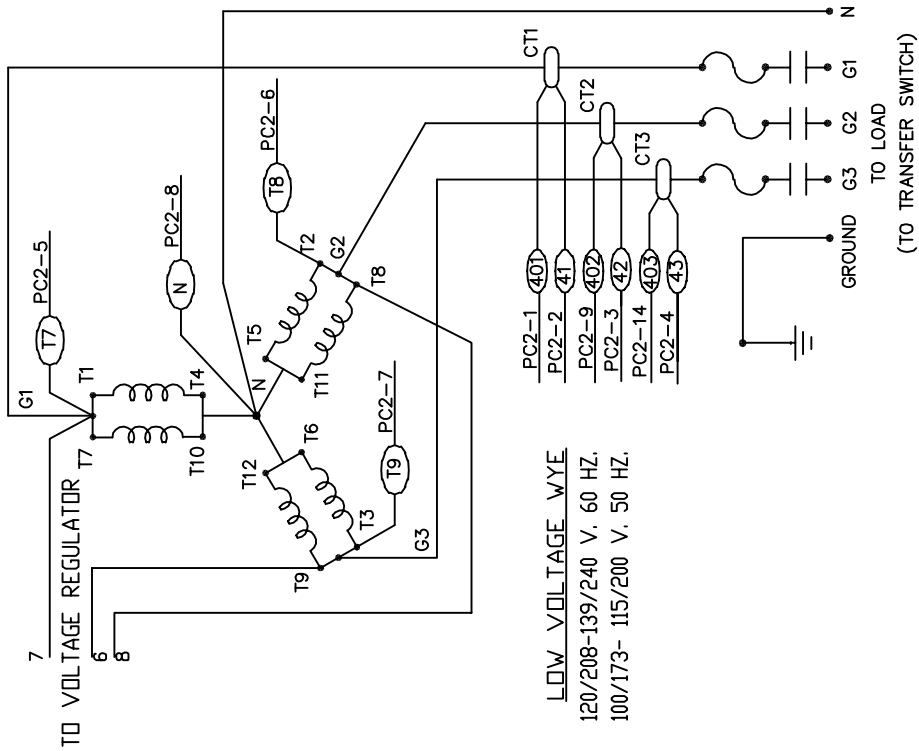

ULPSS60-17/B & C

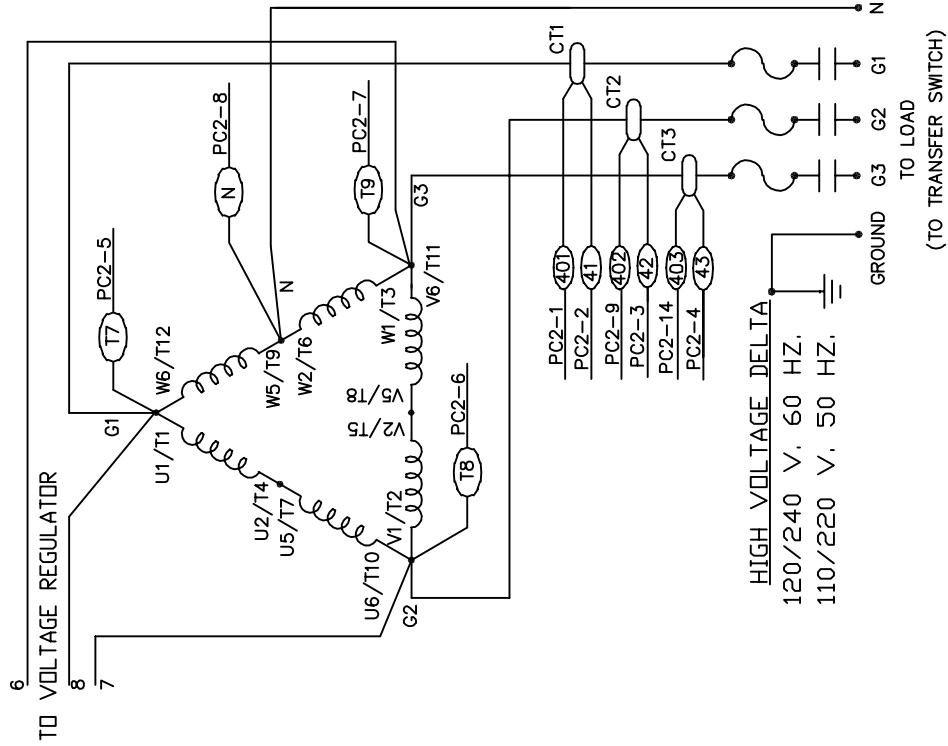

DC WIRING SCHEMATIC DSE7110

TO A.C. POWER GENERATOR

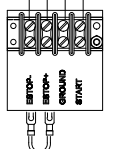
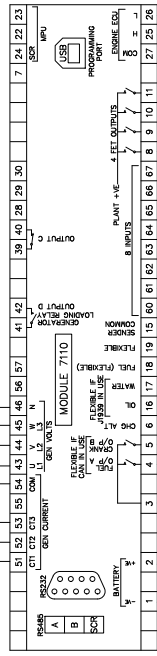
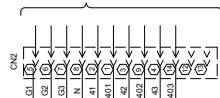

- LEGEND**
- CN1 16 PIN (LARGE CONNECTOR)
 - ENGINE CONTROL HARNESS
 - CN2 14 PIN GENERATOR HARNESS
 - AC CONTROL HARNESS
 - CANH CANBUS HIGH
 - CANL CANBUS LOW
 - ESS EMERGENCY STOP SWITCH
 - GRD GROUND (CHASSIS OR FRAME)
 - LCL OPTIONAL LOW COOLANT LEVEL PROBE
 - FS FUEL SOLENOIDS
 - FSS FUEL SELECT SWITCH

- S - BLACK
- R - BROWN/WHITE
- P - BLUE/WHITE
- N - BLUE/PINK
- M - DK BLUE/YELLOW
- L - GRAY/DK BLUE
- K - DK BLUE/RANGE
- J - DK BLUE/RED
- H - TAN/BROWN
- G - GREEN/YELLOW
- F - LT BLUE/PINK
- E - BROWN/PINK
- D - PINK/DK GREEN
- C - LT BLUE/WHITE
- B - WHITE/BLACK
- A - PINK/TAN

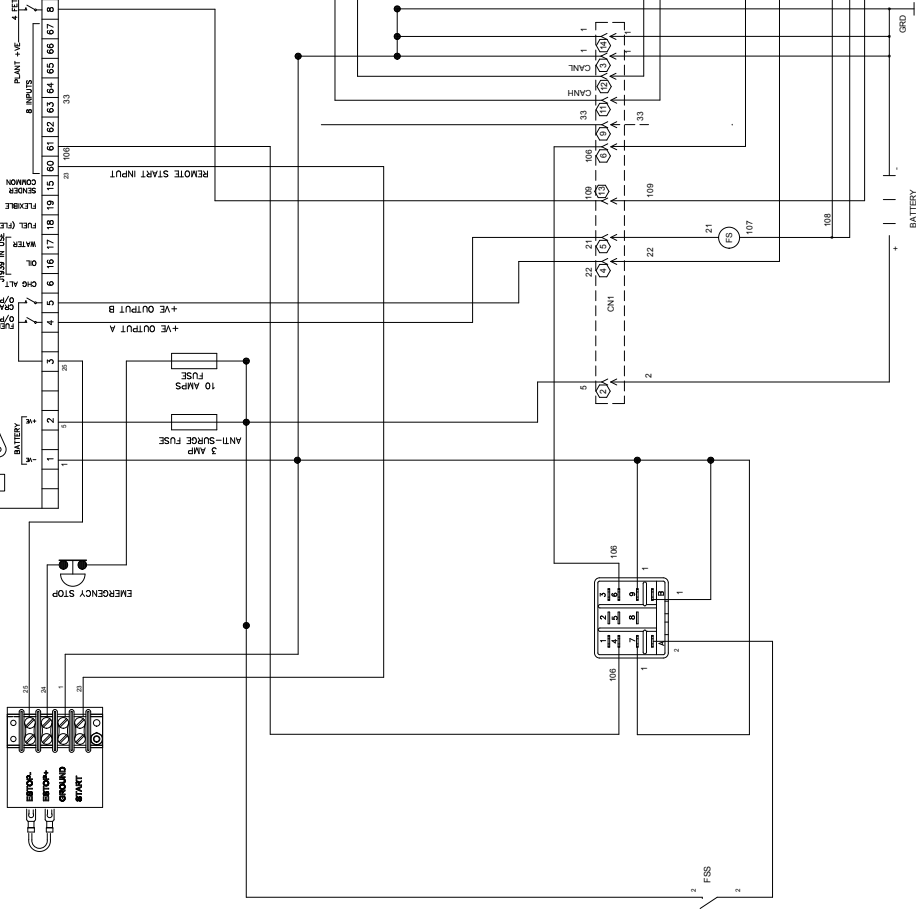

- GROUND
- AUX PWN 5
- CAN -
- CAN +
- AUX ANA PUD 1
- GOV 1
- AUX ANA PUD3
- AUX ANA PUD2
- FUEL SELECT
- MIL
- START COMMAND
- AUX PWN 4
- RELAY POWER
- LOCKOFF (SECONDARY)
- LOCKOFF (PRIMARY)
- VSW

- #1 BAT NEG
- NOT USED
- CANL
- CANH
- NOT USED
- NOT USED
- NOT USED
- NOT USED
- FUEL SELECT
- NOT USED
- #22 START COMMAND
- NOT USED
- NOT USED
- #108 LP FUEL SOLENOID
- #107 NG FUEL SOLENOID
- #109 BATTERY POSITIVE

DC WIRING SCHEMATIC DSE7310

