



## ILLUSTRATED PARTS LIST

**PSS65-3/B**

**PSS65-4/B**

**PSS65-17/B**

**PSS65-18/B**



225 S. CORDOVA AVE.  
LECENTER, MN 56057  
507-357-6821  
SERVICE DEPT.  
507-357-6831

# ENGINE / GENERATOR ASSEMBLY

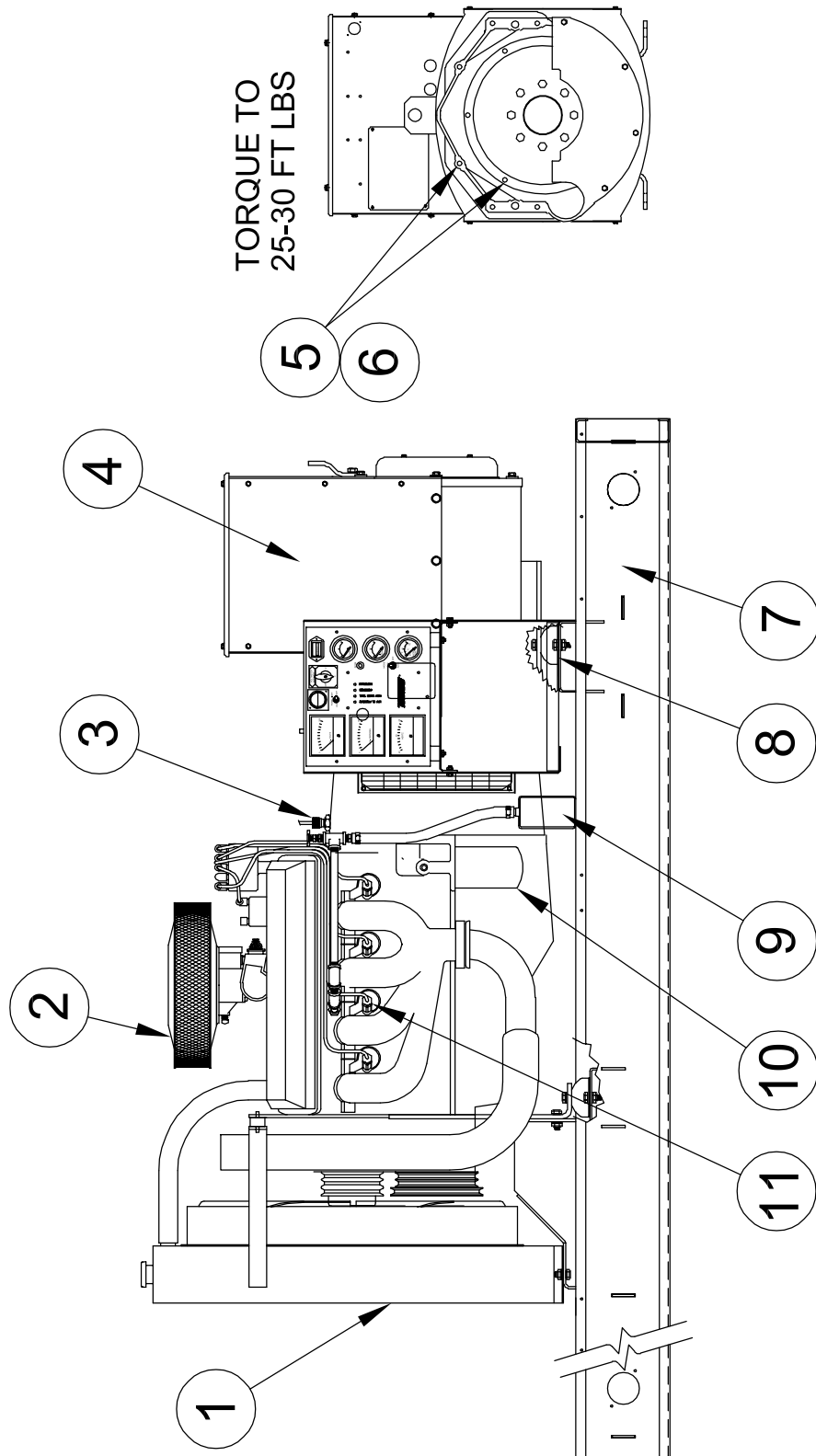

REF #	PART NUMBER	QTY	DESCRIPTION
1	SEE TABLE	1	Engine, GM 7.4 Liter
2	F1-9	1*	Air Filter
3	350101-1	1	Magnetic Pick-up
4	SEE TABLE	1	Generator
5	96000-004	12	3/8"-16 X 1-1/2" Bolt
6	481-001	12	3/8" Split Lock Washer
7	99381-011	1	Base Assembly
8	98956-001	4	Shockmount
9	Reference	1	Block Heater Assembly
10	PF1218	1**	Oil Filter
11	MR43LTS	8**	Spark Plug
*	IMPCO Part #		
**	AC Delco Part #		

MODEL #	PART #
PSS65/BNG	350775-13
PSS65/BLPG	350775-15
PSS65/BLP	350775-14

MODEL #	STAMFORD NEWAGE MODEL #	WINCO PART #
PSS65-3/B	UCI224F 4-LEAD	350685-41
PSS65-4/B PSS65-17/B PSS65-18/B	UCI224F 12-LEAD	350685-4

# ENGINE HEATER ASSEMBLY

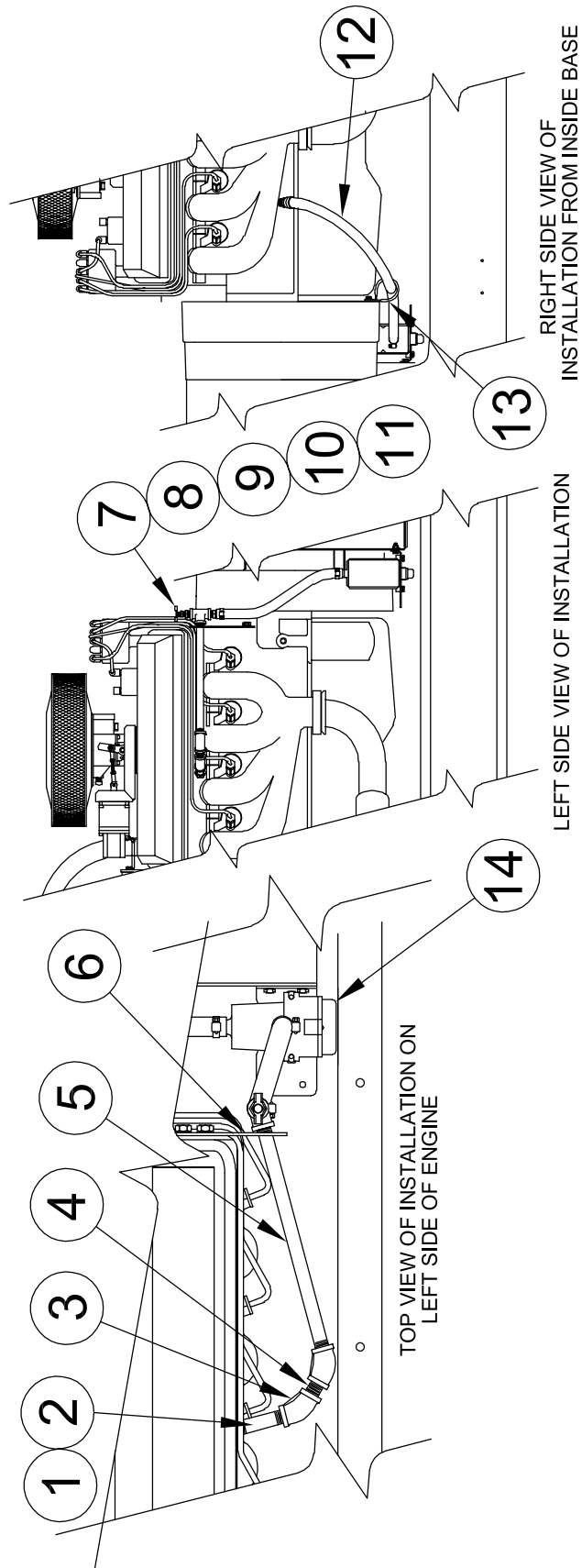

REF #	PART NUMBER	QTY	DESCRIPTION
1	56372-000	1	3/8" to 1/2" Reducer
2	21856-000	1	3/8" X 2.5" Pipe Nipple
3	56896-001	2	3/8" 45° Elbow
4	53244-003	1	3/8" X 2" Pipe Nipple
5	53244-012	1	3/8" X 10" Pipe Nipple
6	96979-001	1	Support Plate
7	93824-000	1	1/4" Petcock Valve
8	56348-000	1	1/4" to 3/8" Reducer
9	92790-002	1	3/8" Pipe Tee
10	92388-000	1	5/8" to 3/8" Fitting
11	93689-001	16"	5/8" Heater Hose
12	93689-001	34"	5/8" Heater Hose
13	97391-009	1	Cushioned Tube Clamp
14	350087-2	1	1000W 120V Heater

# CONTROL BOX ASSEMBLY

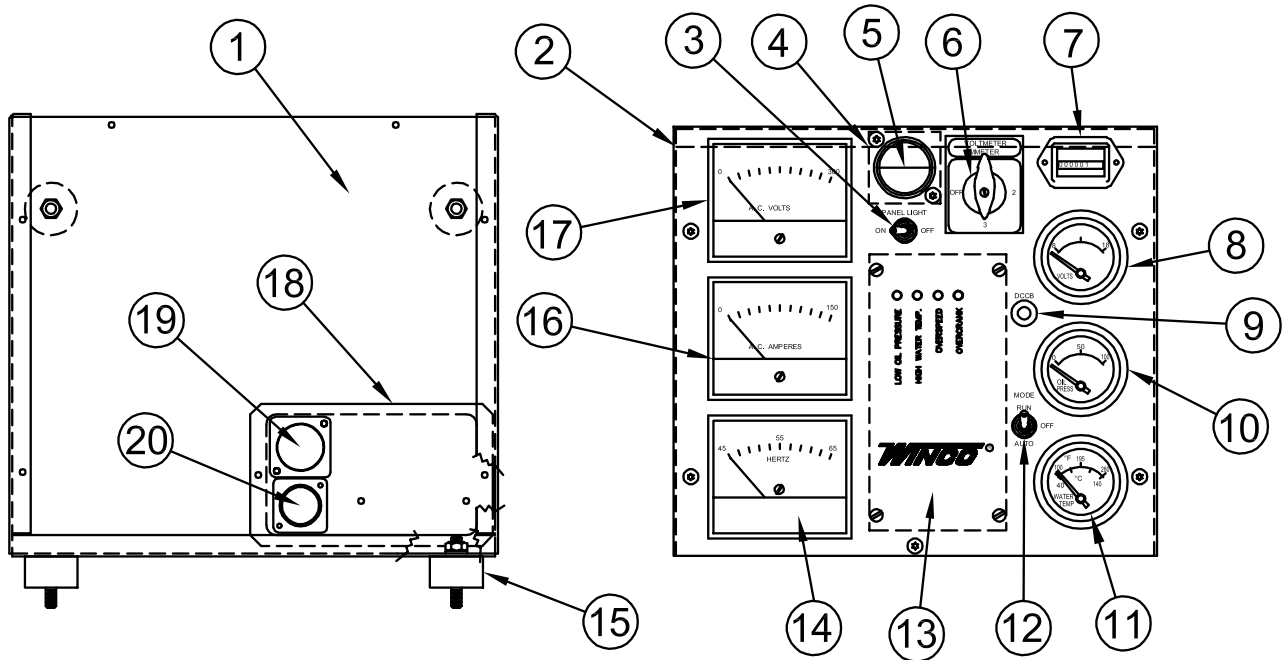

REF #	PART NUMBER	QTY	DESCRIPTION
1	99056-000	1	Rear Panel
2	99055-001	1	Front Panel
3	71215-001	1	SPST Toggle Switch
4	95807-000	1	License Light
5	99297-000	1	Backing Plate
6	SEE TABLE	1	Voltmeter, Ammeter Switch
7	58166-006	1	Running Time Meter
8	99268-000	1	DC Voltmeter
9	91286-000	1	15 Amp Breaker
10	99266-000	1	Oil Pressure Gauge
11	99264-000	1	Temperature Gauge
12	71216-001	1	DPDT Toggle Switch
13	64813-400	1	Engine Control Module
14	99272-002	1	Frequency Meter
15	71605-003	4	Shock Mount
16	SEE TABLE	1	Ammeter
17	SEE TABLE	1	Voltmeter
18	99343-000	1	Connector Backing Plate
19	96925-002	1	Connector
20	96925-005	1	Connector

NI  
NI

SEE TABLE  
Not Illustrated

2 or 3

Current Transformer

MODEL #	PART NUMBER	DESCRIPTION
PSS65-3/A & B	99003-001	VOLTMETER, AMMETER SWITCH
PSS65-4/A & B PSS65-17/A & B PSS65-18/A & B	99003-000	VOLTMETER, AMMETER SWITCH

MODEL #	PART NUMBER	DESCRIPTION
PSS65-3/A & B	99271-005	AMMETER
PSS65-4/A & B PSS65-17/A & B	99271-004	AMMETER
PSS65-18/A & B	99271-002	AMMETER

MODEL #	PART NUMBER	DESCRIPTION
PSS65-18/A & B	99270-002	VOLTMETER
PSS65-3/A & B PSS65-4/A & B PSS65-17/A & B	99270-003	VOLMETER

MODEL #	PART NUMBER	DESCRIPTION	QTY
PSS65-3/A & B	71234-006	CURRENT TRANSFORMER	2
PSS65-4/A & B PSS65-17/A & B	71234-001	CURRENT TRANSFORMER	3
PSS65-18/A & B	71234-004	CURRENT TRANSFORMER	3

# CONTROL PANEL WIRING DIAGRAM SINGLE PHASE

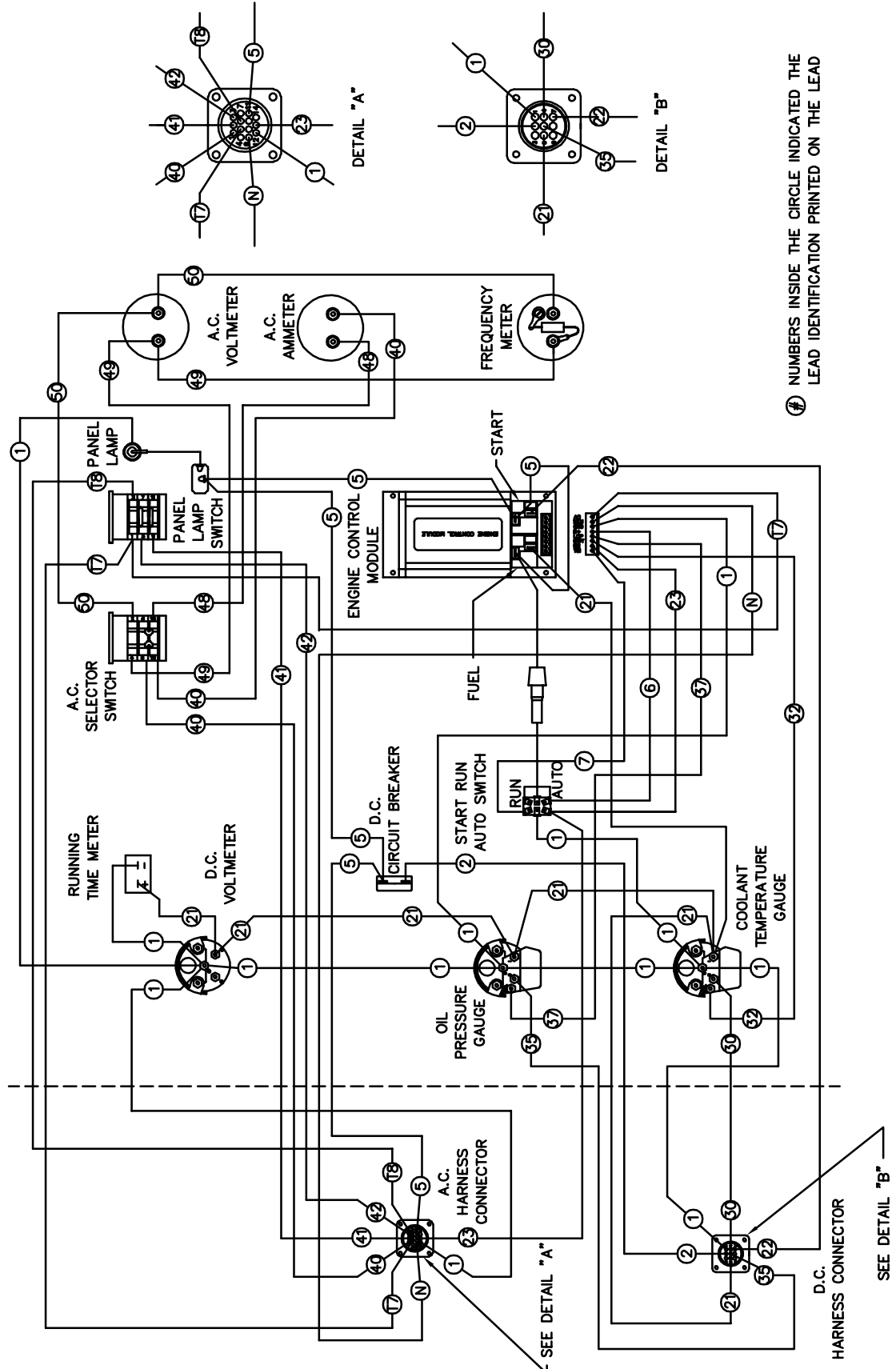

NUMBERS INSIDE THE CIRCLE INDICATED THE LEAD IDENTIFICATION PRINTED ON THE LEAD



# CONTROL PANEL WIRING DIAGRAM THREE PHASE

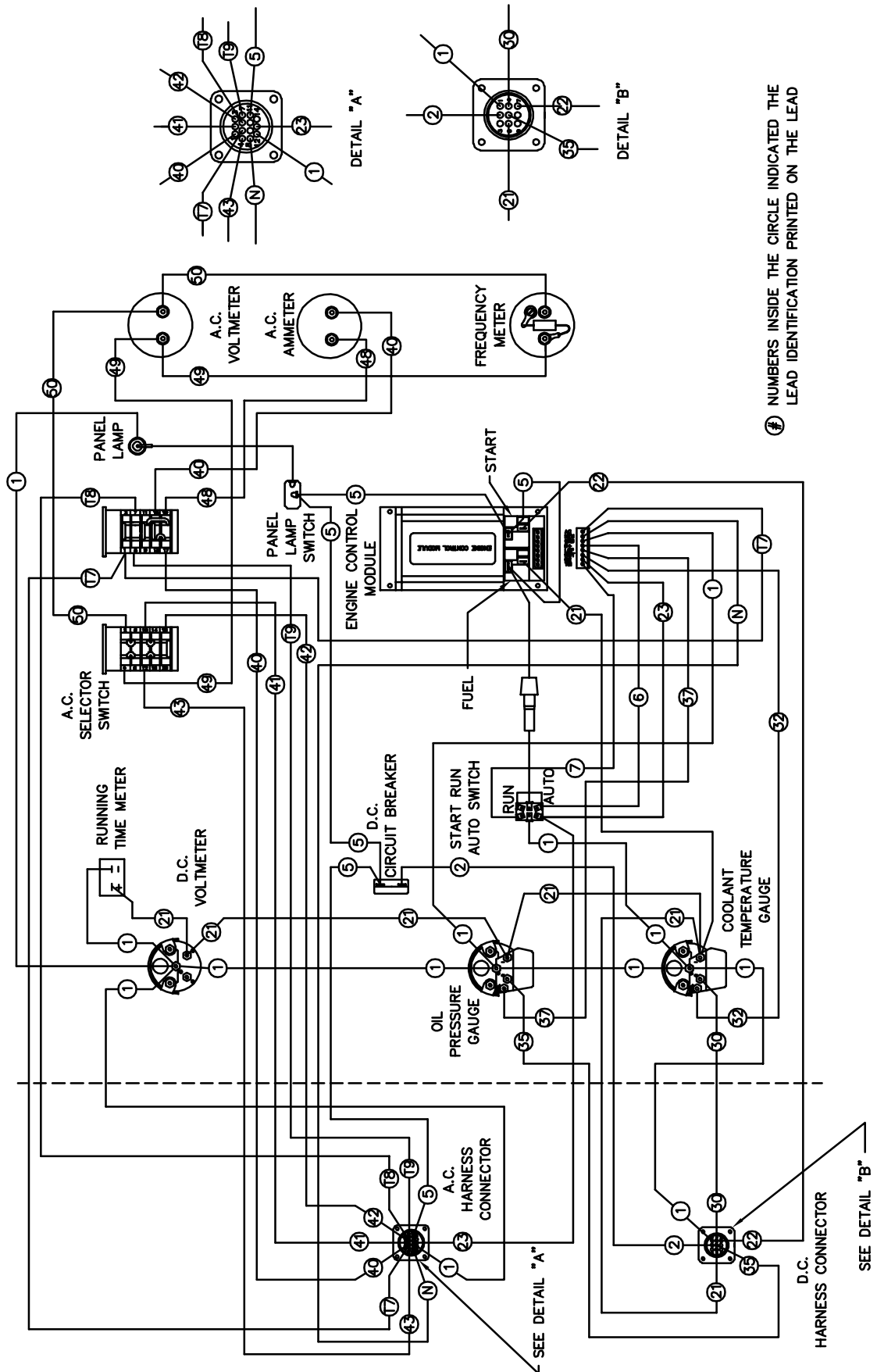

# ENGINE CONTROL WIRING ASSEMBLY

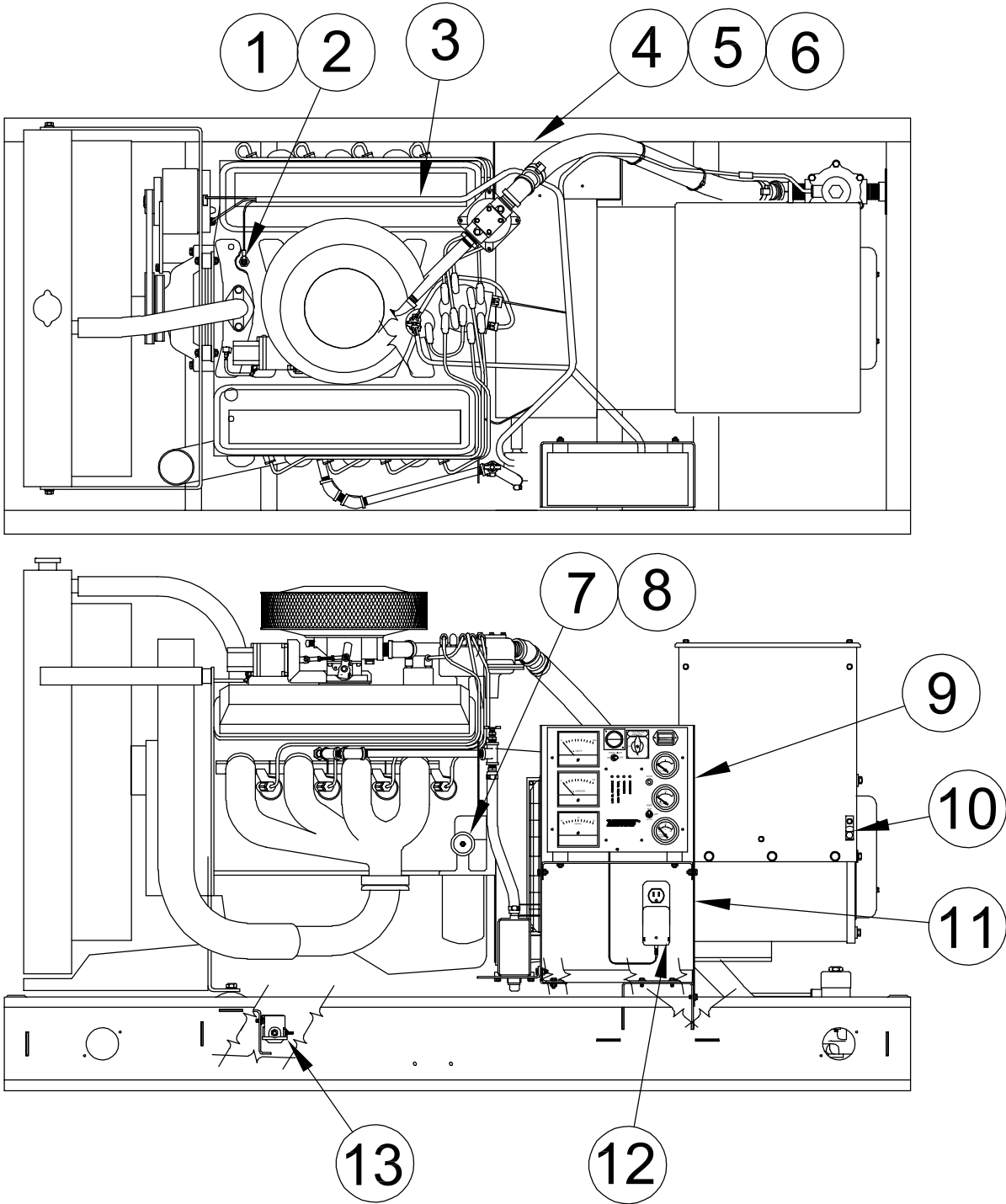

REF #	PART NUMBER	QTY	DESCRIPTION
1	99265-000	1	Temperature Sender
2	56372-000	1	3/8" to 1/2" Reducer
3	99420-006	1	Engine Control Harness
4	99317-001	1	Battery Tray
5	53220-013	1	Negative (-) Battery Cable
6	53220-058	1	Positive (+) Battery Cable
7	99267-001	1	Oil Pressure Sender
8	91750-000	1	1/8" to 3/8" Reducer
9	99057-006	1	Support Pedestal
10	48042-000	1	Ground Lug
11	99057-002	1	Support Bracket
12	Reference	1	Battery Charger Assembly
13	80980-000	1	Start Control Solenoid

## AC WIRING ASSEMBLY

REF #	PART NUMBER	QTY	DESCRIPTION
1	SEE TABLE	2 or 3	Current Transformer
2	92789-000	1	Conduit Box
3	59026-000	1	Conduit Box Cover
4	40730-000	1	Grommet
5	350028-13	1	Rear Panel
6	23917-000	1	Grommet
7	62480-000	1	Grommet
8	99347-001	1	AC Harness
NI	350818	1	SX 460 Voltage Regulator
NI	Not Illustrated		

MODEL #	PART NUMBER	DESCRIPTION	QTY
PSS60-3/B	71234-006	400:5 CURRENT TRANSFORMER	2
PSS60-4/B PSS60-17/B	71234-001	300:5 CURRENT TRANSFORMER	3
PSS60-18/B	71234-004	150:5 CURRENT TRANSFORMER	3

# AC WIRING ASSEMBLY PSS65-3/B

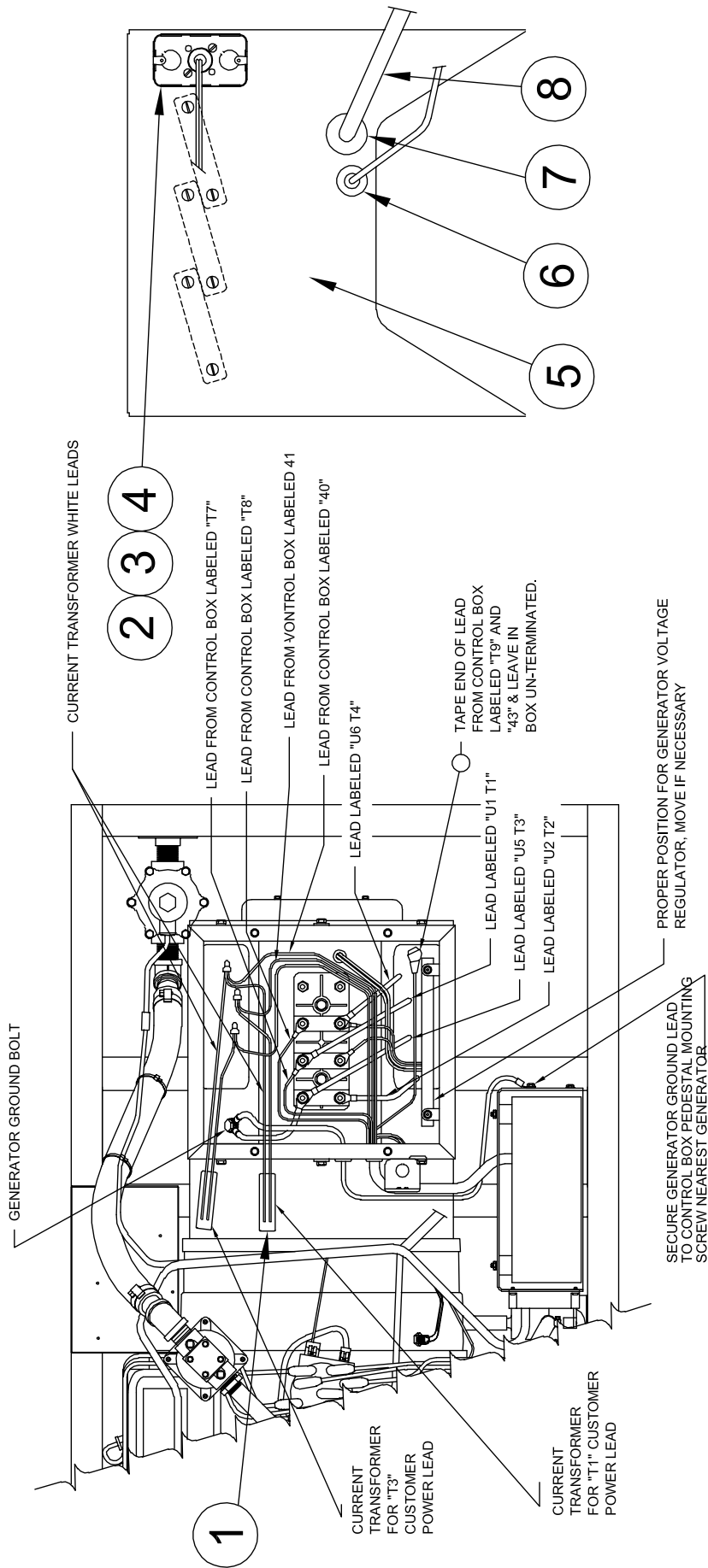

# AC WIRING ASSEMBLY PSS65-4/B

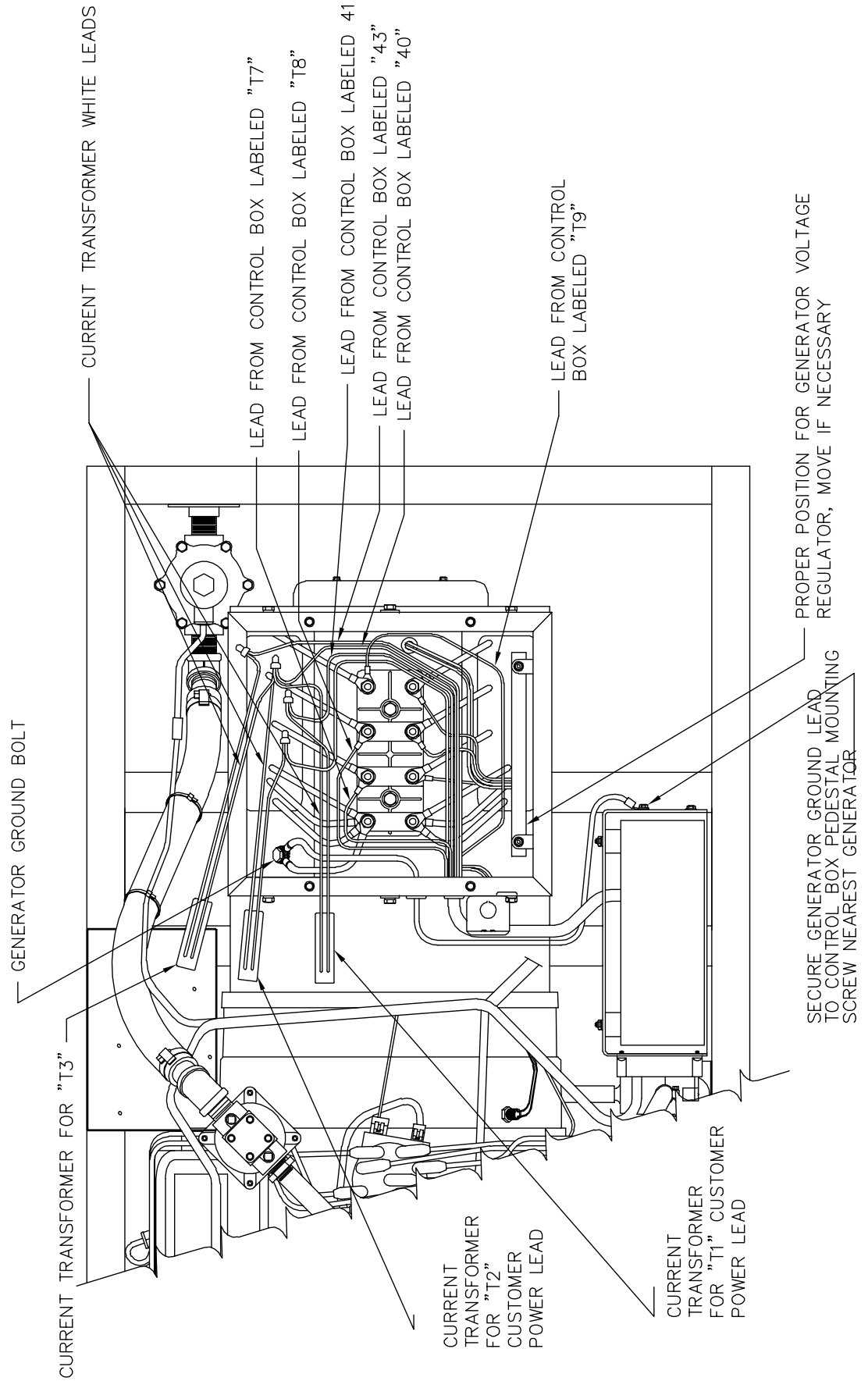

# AC WIRING ASSEMBLY PSS65-17/B

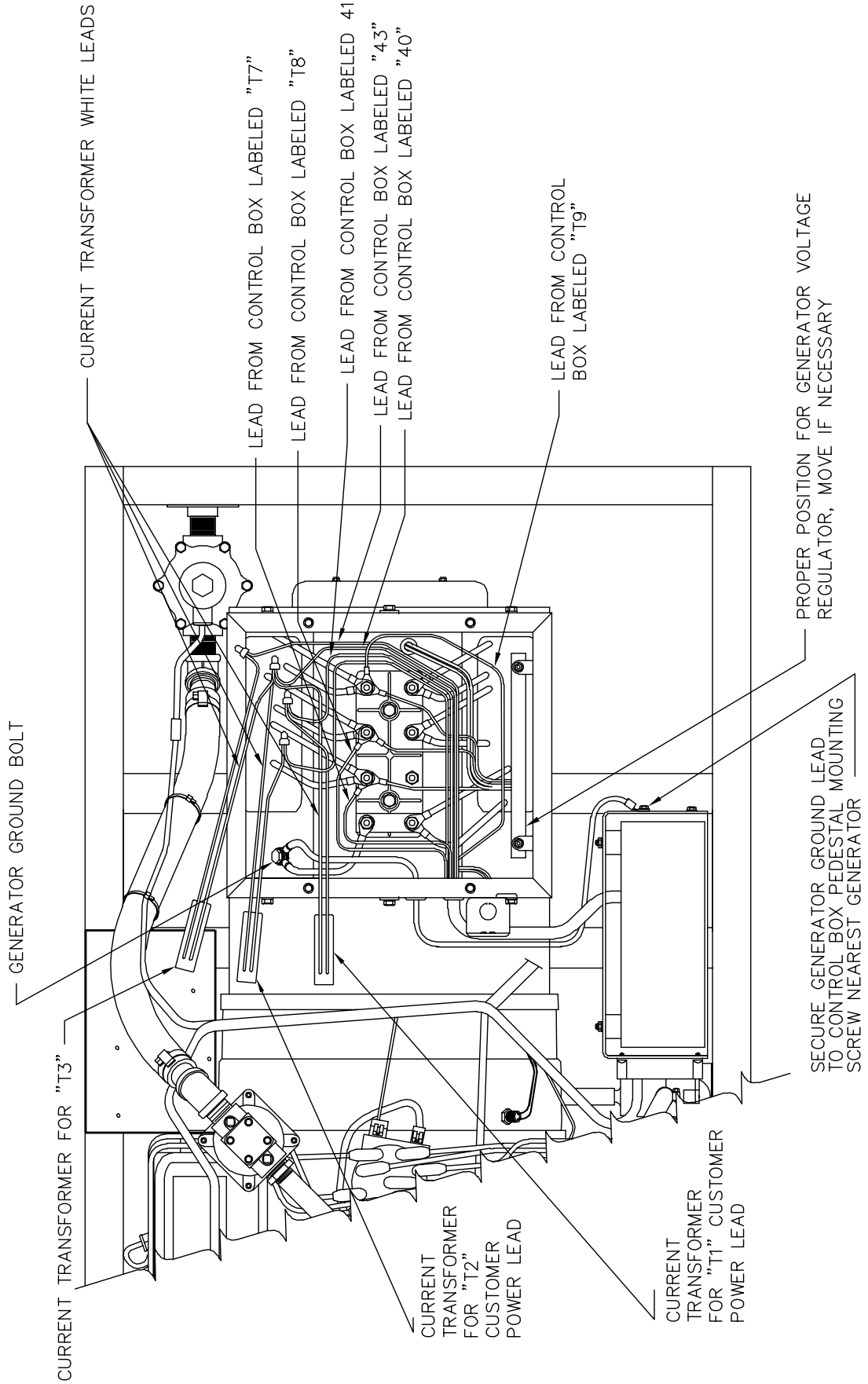

# AC WIRING ASSEMBLY PSS65-18/B

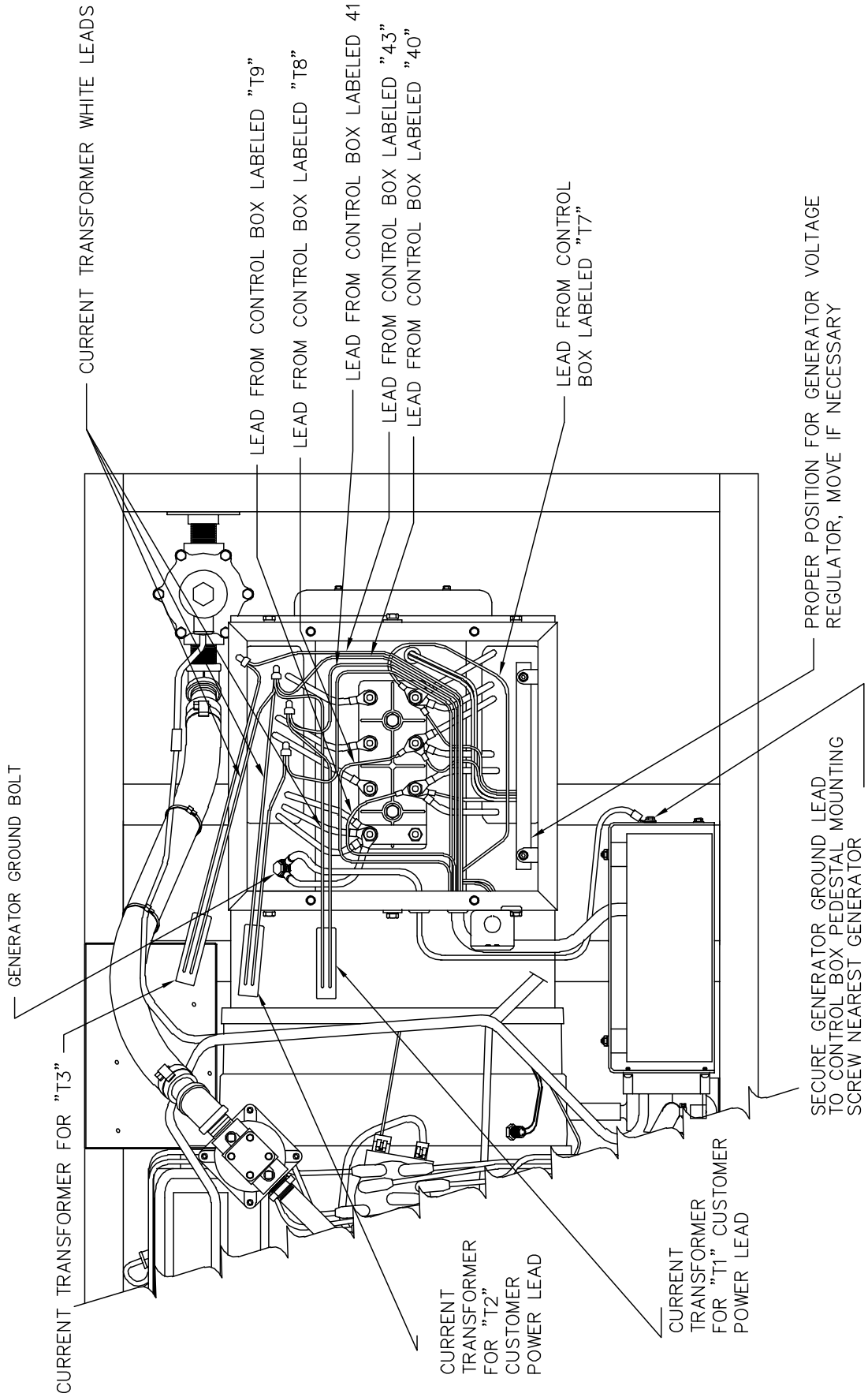

# VAPOR FUEL SYSTEM ASSEMBLY PSS65/B

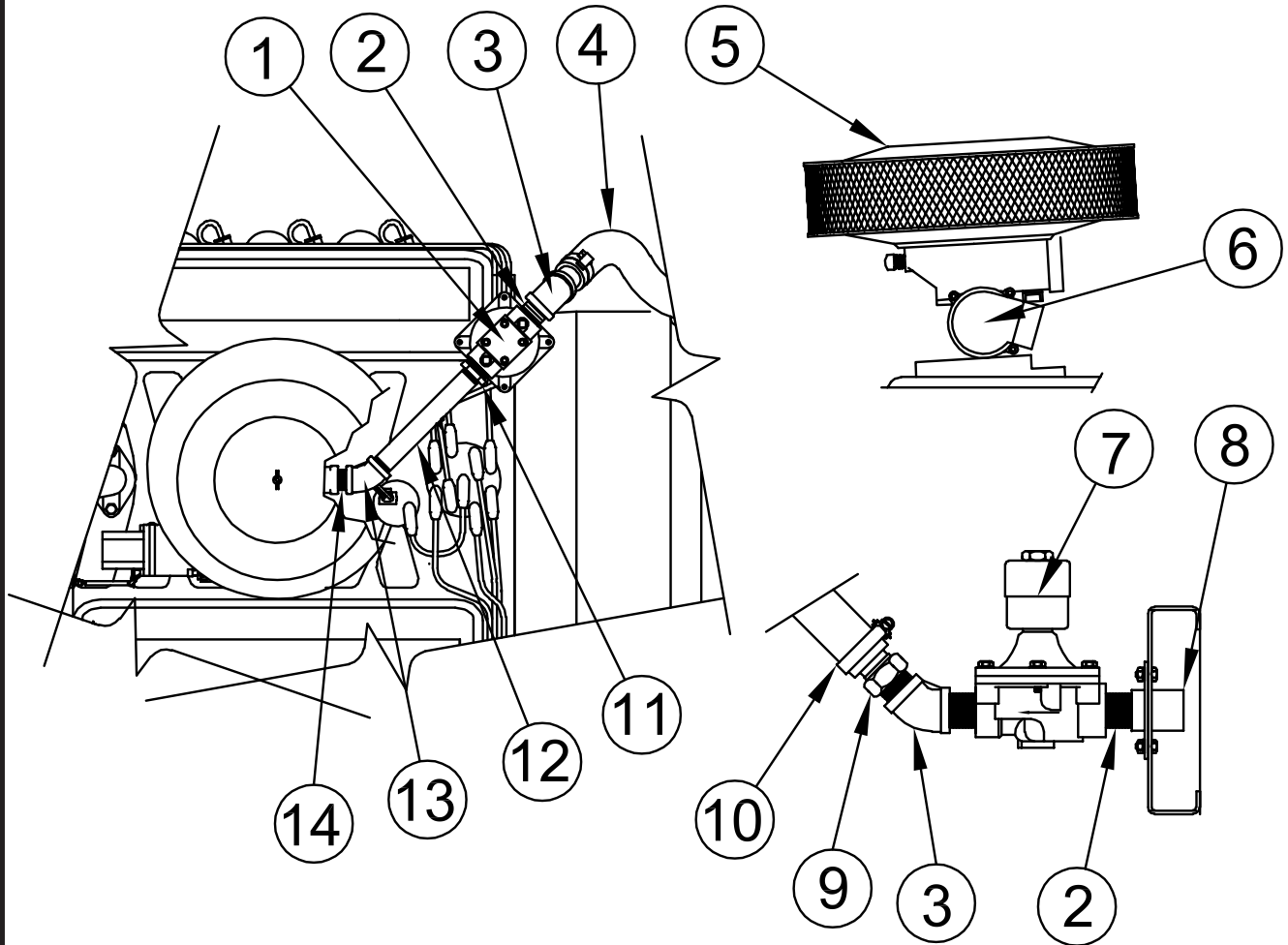

REF #	PART NUMBER	QTY	DESCRIPTION
1	81017-000	1	Regulator
2	81079-000	3	1" Pipe Nipple
3	23996-000	2	1" X 45° Pipe Elbow
4	81103-000	4 FT	1-1/4" I.D. Hose
5	F1-9	1*	Air Filter
6	38900362	1**	"L" Series Governor
7	42942-001	1	Solenoid
8	99065-000	1	Fuel Inlet Weldment
9	92388-006	2	Hose Fitting
10	81018-001	2	Hose Clamp
11	81077-000	1	3/4" to 1" Reducer
12	54074-007	1	3/4" X 8" Pipe Nipple
13	56896-000	1	3/4" X 45° Pipe Elbow
14	22626-000	1	3/4" Pipe Nipple

\* Impco Part #

\*\* PSI Part Number

PSI (Power Solutions Inc.) Phone: (630)-350-9400



# LP LIQUID WITHDRAWAL ASSEMBLY

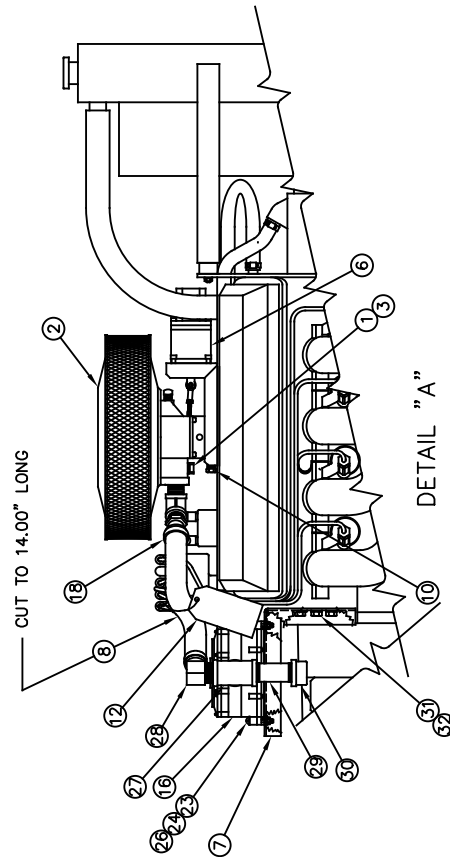
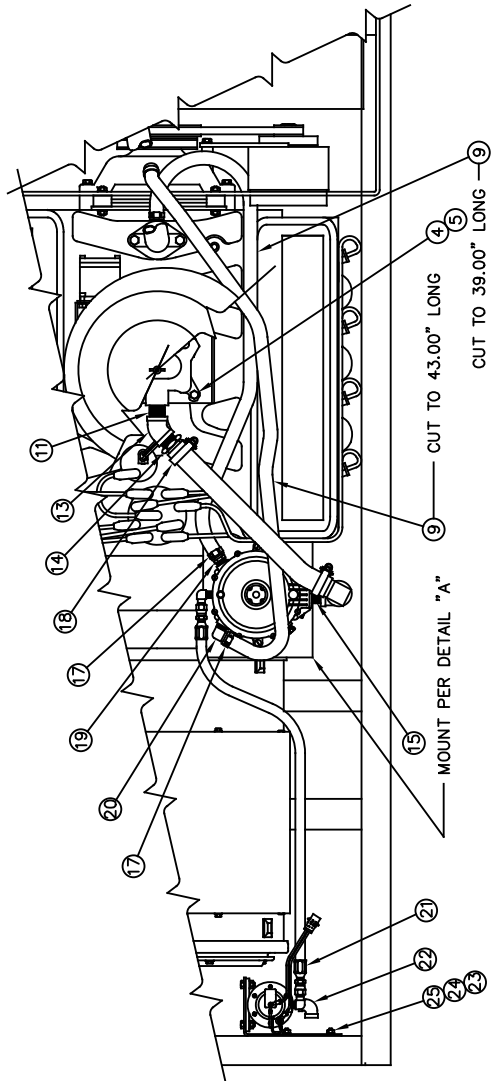

ITEM	PART NO	QUAN.	DESCRIPTION
32	A-90570-000	2	7/16" SPLIT LOCKWASHER
31	93617-001	2	7/16-14 X 3/4" LONG HEX HEAD BOLT
30	44109-000	1	1" NPT PIPE CAP
29	A-81079-002	1	1" NPT X 3-1/2" LONG PIPE NIPPLE
28	A-92382-005	1	1" NPT TO 1" I.D. HOSE ZINC 90° ELBOW
27	93018-000	1	1" NPT BLACK IRON PIPE TEE
26	639-000	2	1/4-20 X 1-1/2 ROUND HEAD SCREW
25	638-000	6	1/4-20 HEX NUT
24	479-000	6	1/4 SPLIT LOCKWASHER
23	476-000	4	1/4-20 X 5/8" HEX HEAD BOLT
22	A-99707-000	1	FUEL INLET VALVE ASSEMBLY
21	B-92940-006	1	GAS HOSE ASSEMBLY
20	A-92382-000	1	3/8" PIPE X 5/8" HOSE 90° BRASS ELBOW FITTING
19	A-92388-000	1	3/8" PIPE TO 5/8" HOSE BRASS FITTING
18	A-50245-000	2	HOSE CLAMP, RANGE 1" TO 2"
17	A-81018-004	2	HOSE CLAMP, RANGE 13/16 TO 1-3/4
16	A-81635-000	1	GAS CONVERTER
15	A-81079-000	1	1" NPT X 1-1/2" LONG PIPE NIPPLE
14	A-92388-004	1	FITTING 3/4" PIPE TO 1" HOSE
13	56896-000	1	3/4" BLACK IRON 45° ELBOW
12	A-56597-000	1	FUEL TAG
11	22626-000	1	3/4" NPT X 1.3/8 LONG PIPE NIPPLE
10	23064-000	1	1/4" NPT PIPE PLUG
9	A-56107-000	6.84 FT	5/8" I.D. HOSE
8	A-49409-000	1.17 FT	1" I.D. HOSE
7	B-93088-002	1	CONVERTER MOUNTING BRACKET
6	B-99411-004	1	GOVERNOR ACTUATOR PARTS INSTALLATION DETAILS
5	480-000	8	5/16 SPLIT LOCKWASHER
4	1116-000	8	5/16-18 X 1" LONG HEX HEAD BOLT
3	A-99366-000	1	INTAKE MANIFOLD ADAPTER
2	A-92261-001	1	AIR CLEANER
1	A-92260-002	1	CARBURETOR

# LP LIQUID WITHDRAWAL ASSEMBLY

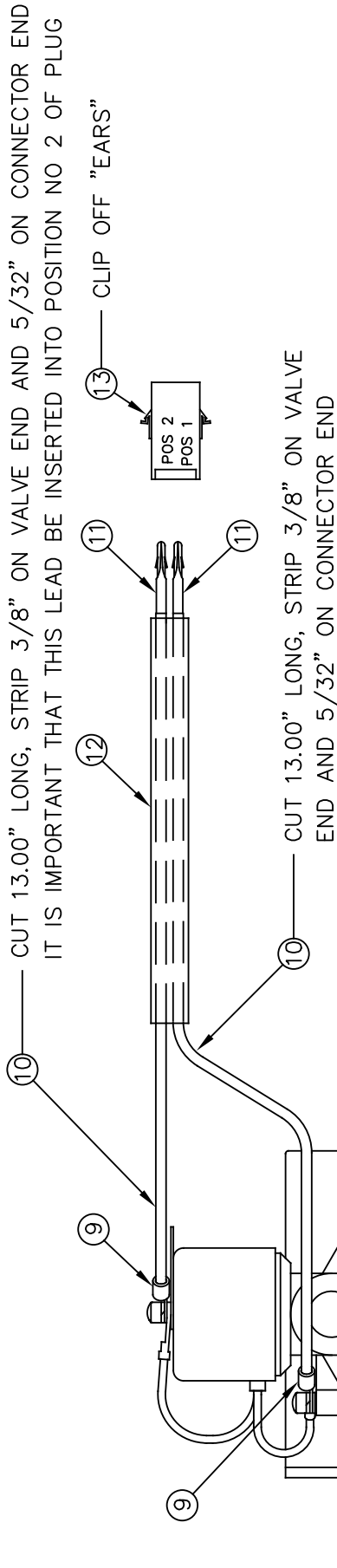

13	A-61641-000	1	PLUG
12	A-45956-000	12	IN. SLEEVING
11	A-61643-000	2	MALE TERMINAL
10	A-10468-000	2.1	FT LEAD WIRE
9	A-4158-000	2	TERMINAL LUG
8			
7	638-000	2	1/4-20 HEX NUT
6	479-000	2	1/4 SPLIT LOCKWASHER
5	466-000	2	1/4-20 X 3/4 HEX HEAD BOLT
4	A-81375-003	1	1/4 NPT X 1-1/2" LONG PIPE NIPPLE
3	92533-000	1	1/4" NPT 90° ELBOW
2	A-99085-002	1	FUEL VALVE MOUNTING BRACKET
1	A-81976-000	1	FUEL VALVE
ITEM	PART NO	QUAN.	DESCRIPTION

# BATTERY TENDER ASSEMBLY

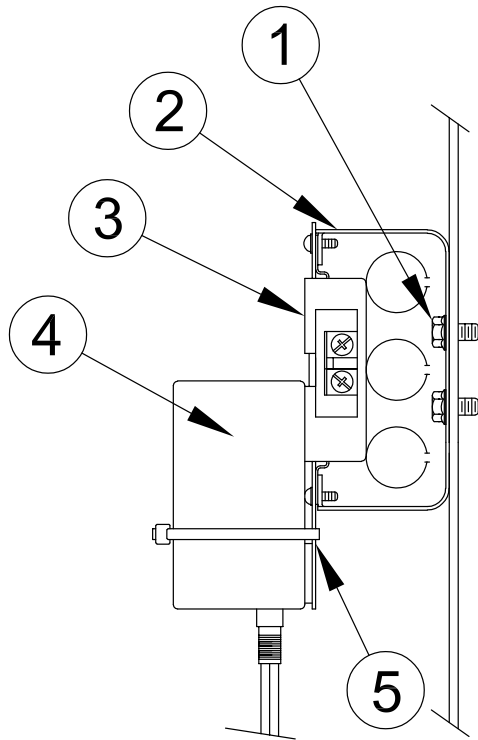

REF #	PART NUMBER	QTY	DESCRIPTION
1	52644-000	2	Self-tapping Screw
2	92789-000	1	Conduit Box
3	24749-000	1	Duplex Receptacle
4	16287-000	1	Battery Tender
5	59026-001	1	Recpt. Cover Plate

# EXHAUST ASSEMBLY

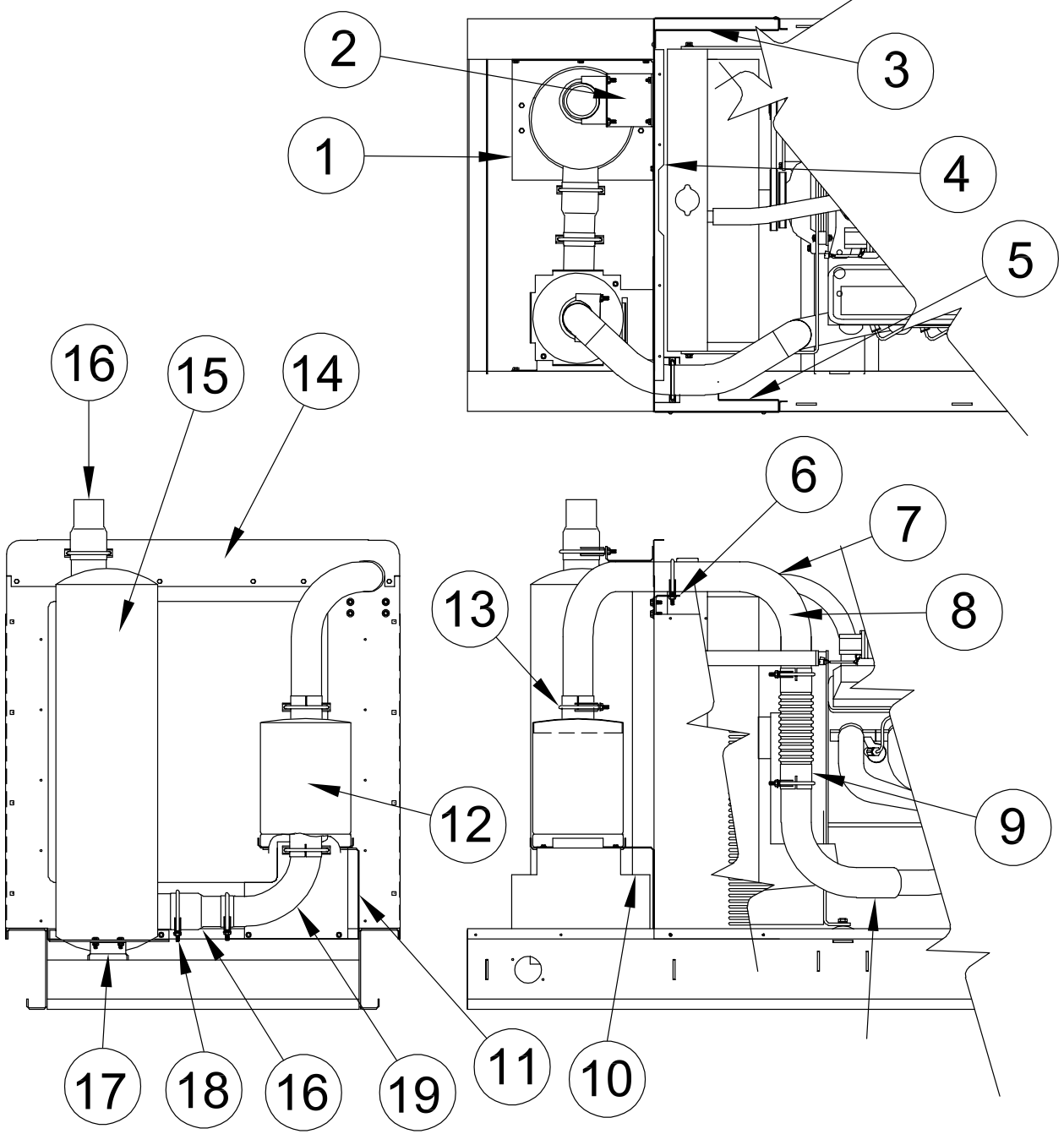

REF #	PART NUMBER	QTY	DESCRIPTION
1	99336-002	1	Muffler Support Tray
2	99336-001	1	Top Muffler Support
3	99378-002	1	Right Front Housing Baffle
4	92421-000	8 FT	1.5" Adhesive Backed Foam
5	99378-000	1	Left Front Housing Baffle
6	99335-002	1	Muffler Support
7	99518-000	20 FT	High Temperature Tape
8	99677-002	1	3" Formed Exhaust Pipe
9	16016-004	1	Flex Exhaust
10	99336-003	1	Resonator Support Bracket
11	99336-004	1	Resonator Support Brace
12	99688-000	1	Resonator
13	93489-001	6	3" Muffler Clamp
14	99334-001	1	Top Housing Front
15	97409-002	1	Muffler
16	97759-007	2	3.5" I.D to 3" O.D. Reducer
17	99337-002	1	Muffler Support Bracket
18	93489-000	2	3.5" Muffler Clamp
19	99502-003	1	3" 90° Elbow

# HOUSING ASSEMBLY

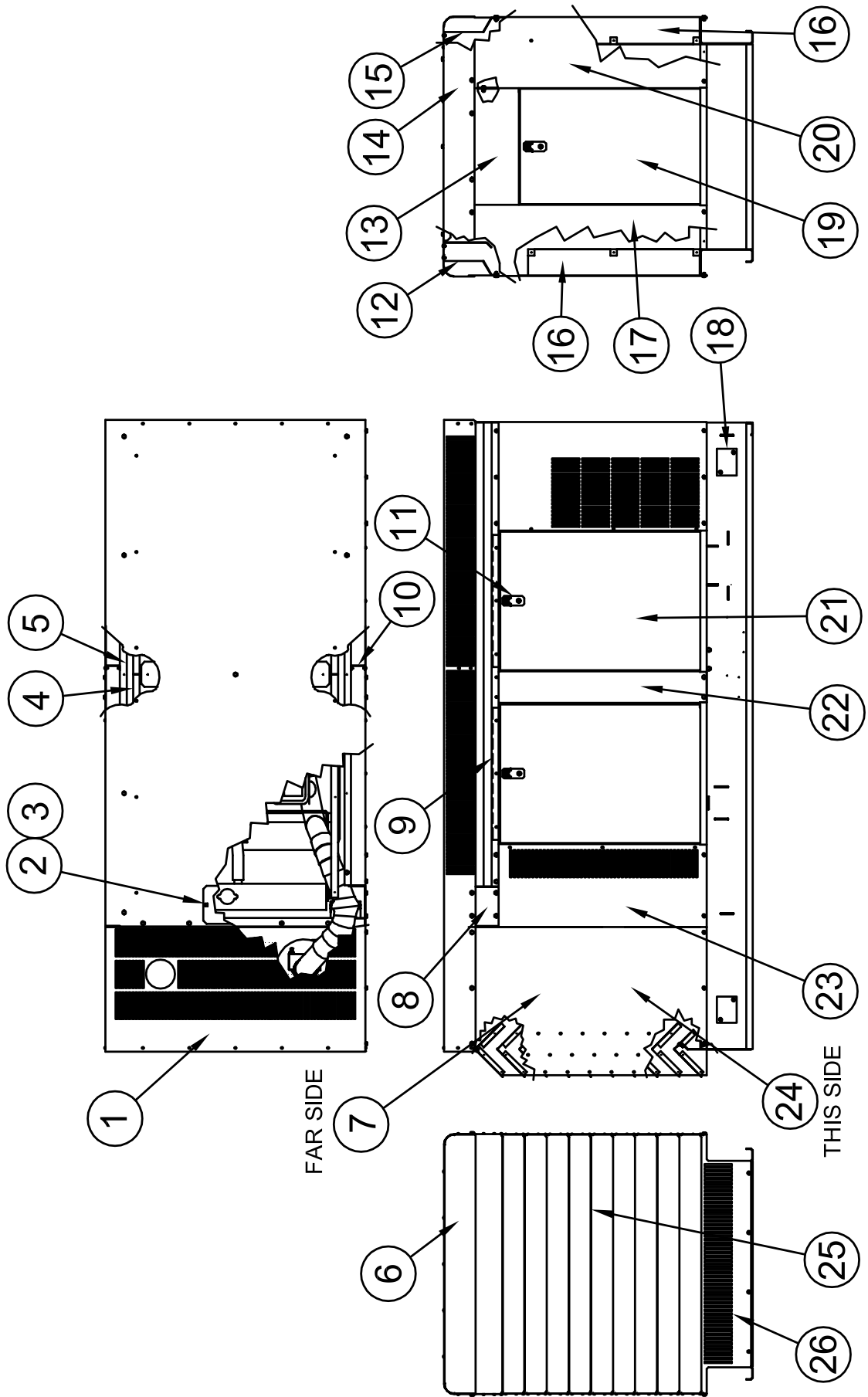

REF #	PART NUMBER	QTY	DESCRIPTION
1	99341-001	1	Roof
2	62912-000	33 FT	Neoprene Strip
3	62026-003	1	Radiator Cap Cover Plate
4	99327-003	1	Side Sill Baffle
5	99327-001	2	Side Sill Baffle
6	99368-001	1	Roof End Panel
7	99329-004	1	Right Extension Panel
8	99325-007	1	Side Sill Extension
9	99333-001	4	Door Jam
10	99339-000	2	Roof Brace
11	95229-004	5	Door Latch
12	99325-002	1	Left Side Sill
13	99326-001	1	Top Rear Sill
14	99368-000	1	Roof End Panel
15	99325-006	1	Right Side Sill
16	99320-001	2	Corner Post Baffle
17	99319-002	1	Left Rear Corner Post
18	99060-000	1	Cover Plate
19	15680-009	1	Rear Door
20	99319-003	1	Right Rear Corner Post
21	15680-015	4	Side Door
22	99323-001	2	Mullion
23	99324-001	1	Housing Front
24	99329-005	1	Left Extension Panel
25	99631-001	8	Louver
26	99331-001	1	Front Extension Panel

## DECALS

REF #	PART NUMBER	QTY	DESCRIPTION
NI	15750-001	1	Ground Decal
NI	97813-000	3	Auto Start Warning
NI	15209-000	1	Warning Decal
NI	56596-000	1	Fuel Decal
NI	56597-000	1	Fuel Decal
NI	63941-001	1	Hot Surface Decal
NI	64891-001	1	Electrical Code Decal
NI	63941-003	1	Battery Warning Decal
NI	Not Illustrated		

# AC WIRING SCHEMATICS

## PSS65-3/B

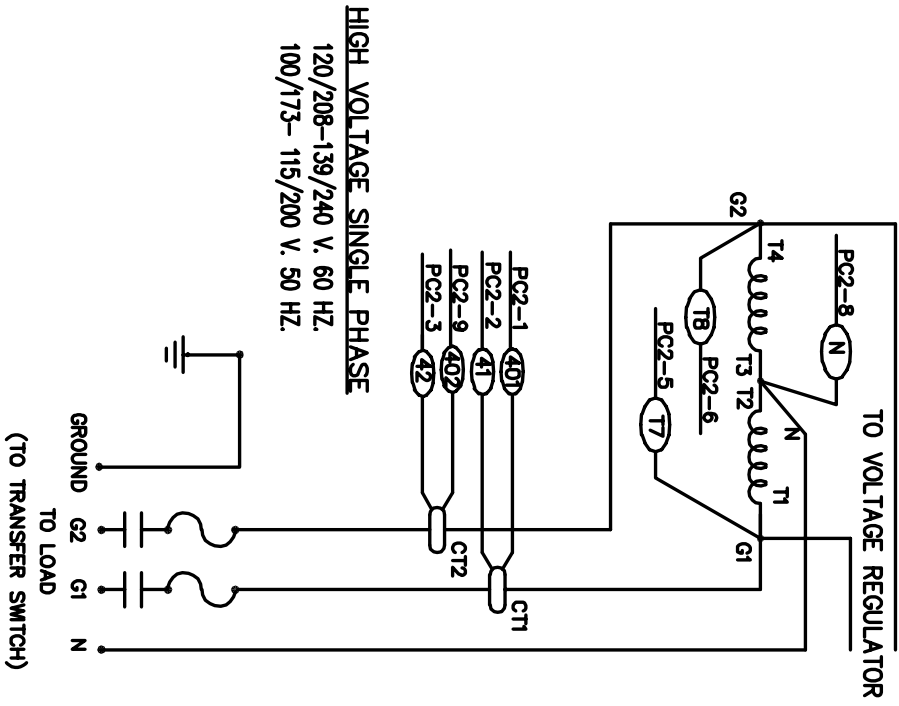

## PSS65-18/B

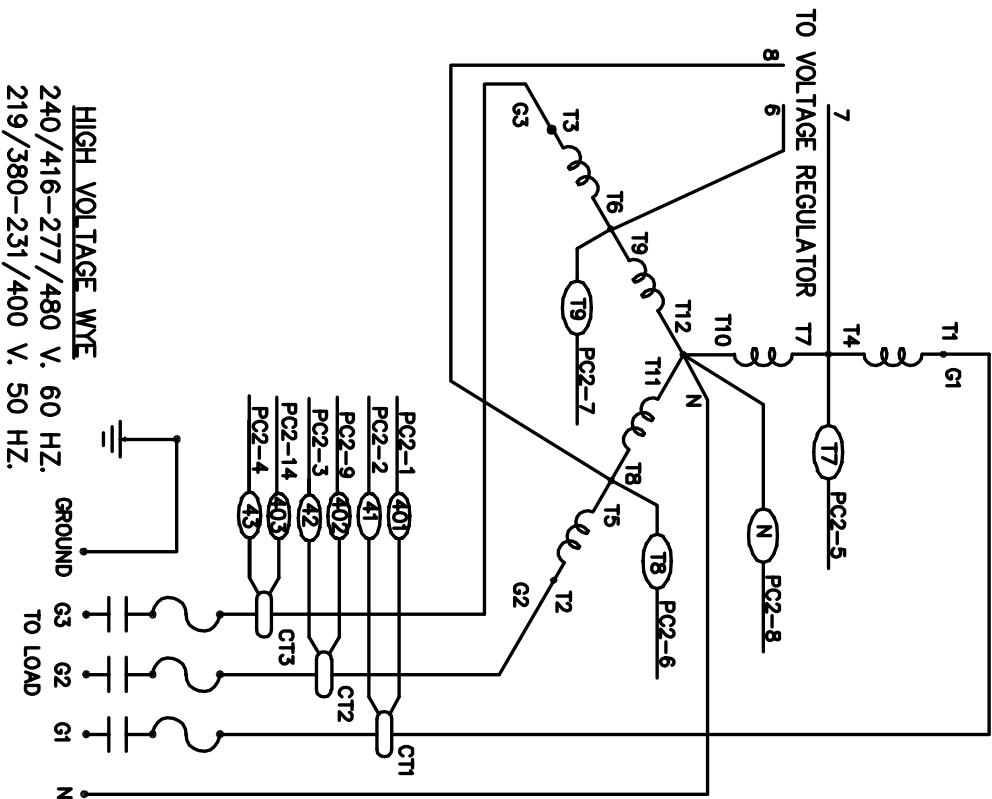



# AC WIRING SCHEMATICS

## PSS65-4/B

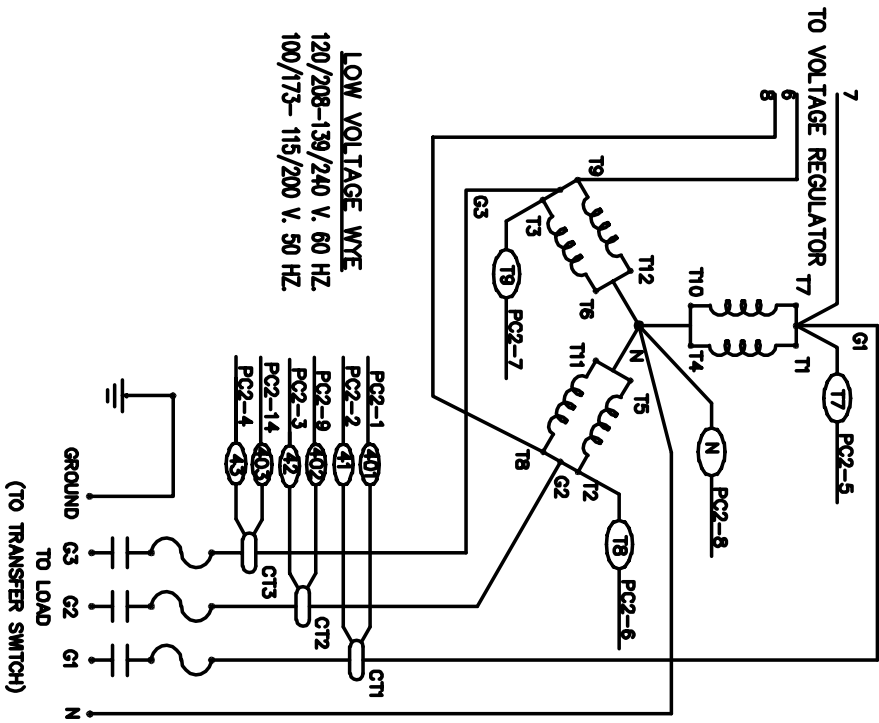

## PSS65-17/B

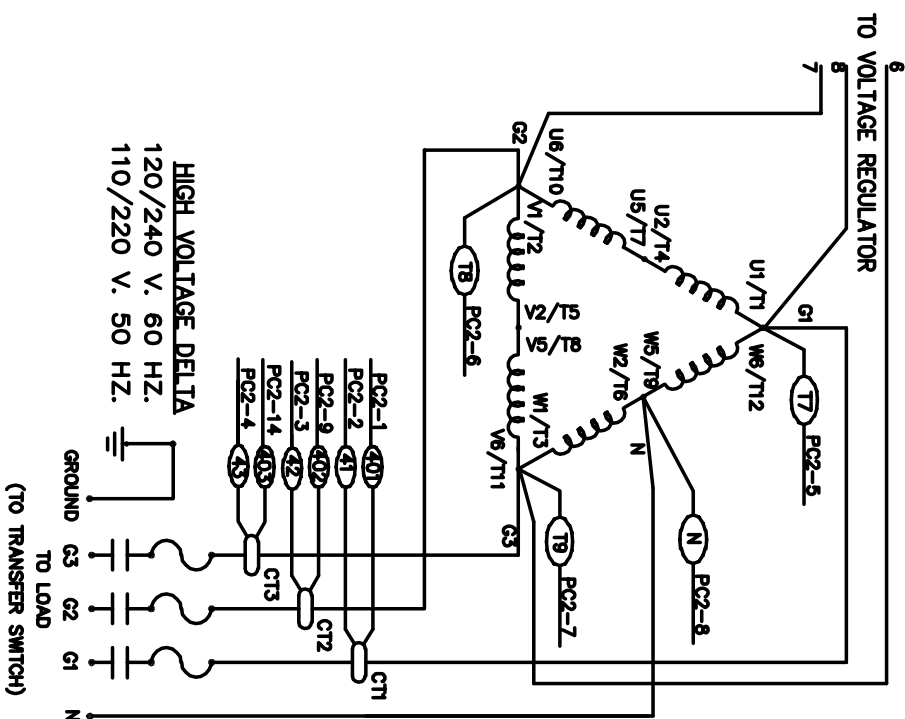

# "LCS" SERIES GOVERNOR (ORIGINAL DESIGN)

## DC WIRING SCHEMATIC

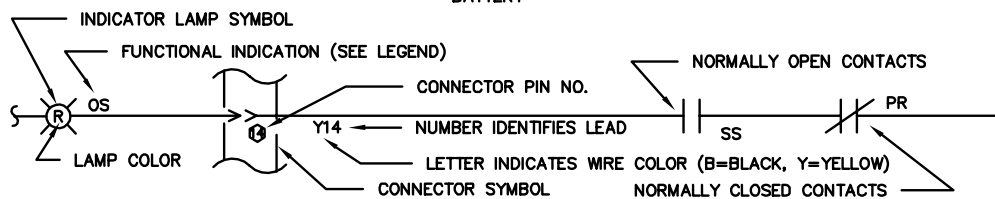
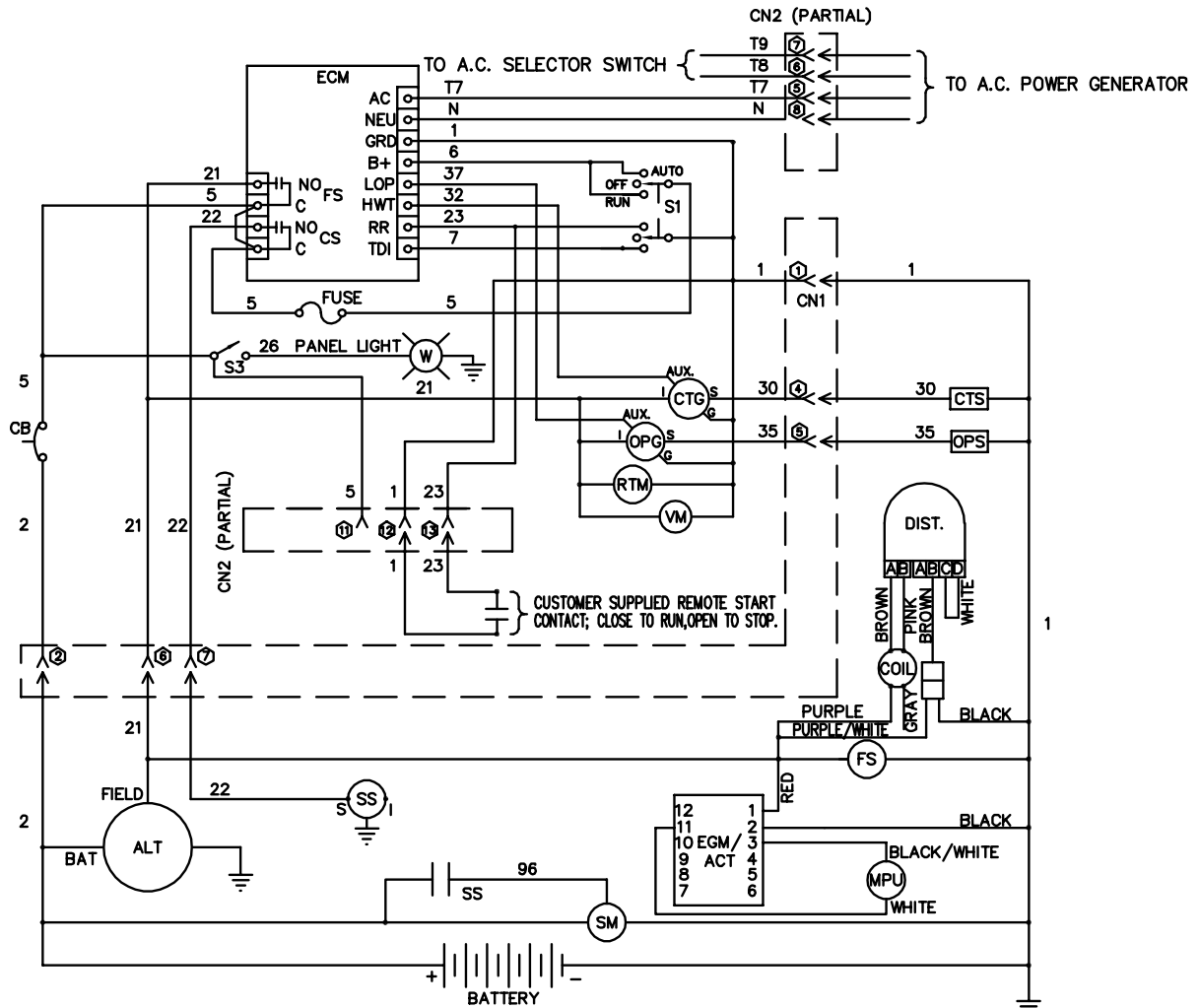

### LEGEND

ALT	ALTERNATOR	OPG	OIL PRESSURE GAUGE
ACT	BATTERY CHARGER	OPS	OIL PRESSURE SENDER
BC	CIRCUIT BREAKER	OS	OVERSPEED INDICATOR LAMP
CB	CIRCUIT BREAKER	PR	PROTECTIVE RELAY, STARTER
CN1,CN2	WIRING HARNESS CONNECTORS	RTM	RUNNING TIME METER
CTG	COOLANT TEMPERATURE GAUGE	S1	ENGINE START MODE SWITCH
CTS	COOLANT TEMPERATURE SENDER	S3	PANEL ILLUMINATION LIGHT SWITCH
ECM	ENGINE CONTROL MODULE	S4	ENGINE SHUTDOWN INDICATOR LAMP
EGM/ACT	ELECTRONIC GOVERNOR MODULE / ACTUATOR	SS	ENGINE STARTER MOTOR SOLENOID
FS	FUEL SOLENOID	SM	ENGINE STARTER MOTOR
GND	GROUND (CHASSIS OR FRAME)	VM	D.C. VOLTMETER
MPU	MAGNETIC PICKUP UNIT		

# “L” SERIES GOVERNOR (WITH NEW GOVERNOR REPLACEMENT)

## DC WIRING SCHEMATIC

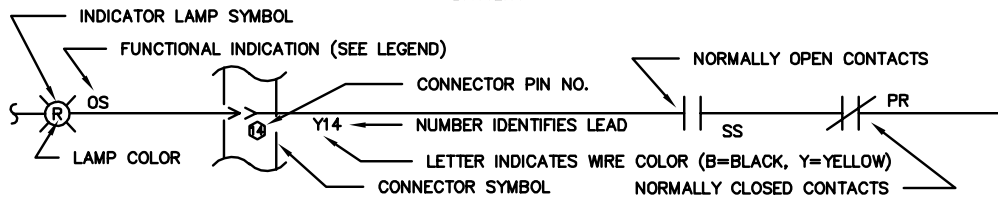
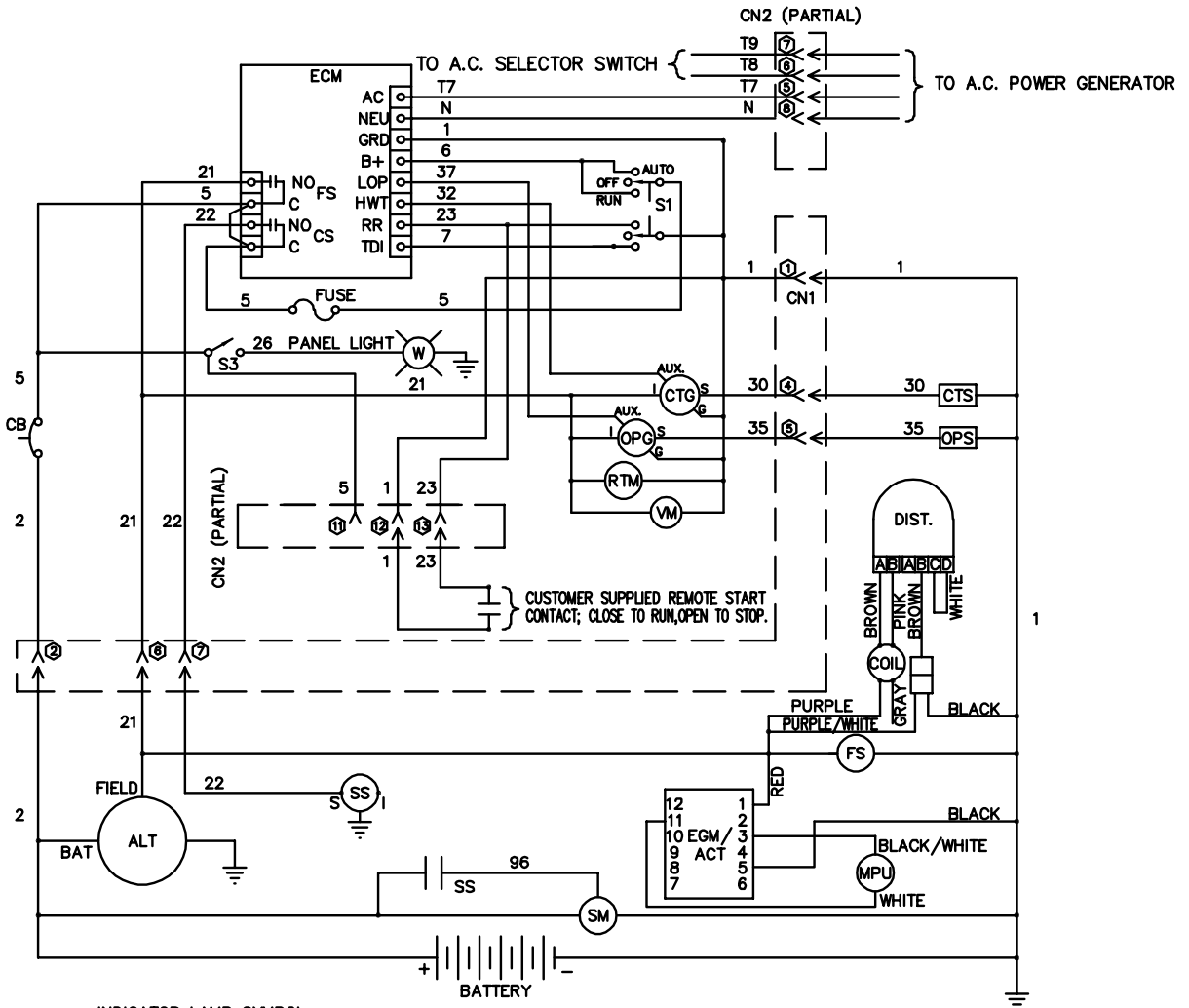

### LEGEND

ALT	ALTERNATOR	OPG	OIL PRESSURE GAUGE
ACT	ACTUATOR	OPS	OIL PRESSURE SENDER
BC	BATTERY CHARGER	OS	OVERSPEED INDICATOR LAMP
CB	CIRCUIT BREAKER	PR	PROTECTIVE RELAY, STARTER
CN1,CN2	WIRING HARNESS CONNECTORS	RTM	RUNNING TIME METER
CTG	COOLANT TEMPERATURE GAUGE	S1	ENGINE START MODE SWITCH
CTS	COOLANT TEMPERATURE SENDER	S3	PANEL ILLUMINATION LIGHT SWITCH
ECM	ENGINE CONTROL MODULE	S4	ENGINE SHUTDOWN INDICATOR LAMP
EGM/ACT	ELECTRONIC GOVERNOR MODULE / ACTUATOR	SS	ENGINE STARTER MOTOR SOLENOID
FS	FUEL SOLENOID	SM	ENGINE STARTER MOTOR
GND	GROUND (CHASSIS OR FRAME)	VM	D.C. VOLTMETER
MPU	MAGNETIC PICKUP UNIT		