



ILLUSTRATED PARTS LIST

PSS27LS/A & /B

PSS27LS/A & /B

PSS27LS/A & /B

PSS27LS/A & /B

2001-2002

WINCO INC.
225 S. CORDOVA AVE.
LE CENTER, MN 56057
(507) 357-6821
SERVICE DEPT.
(507) 357-6831
wincogen.com

GENERATOR ASSEMBLY

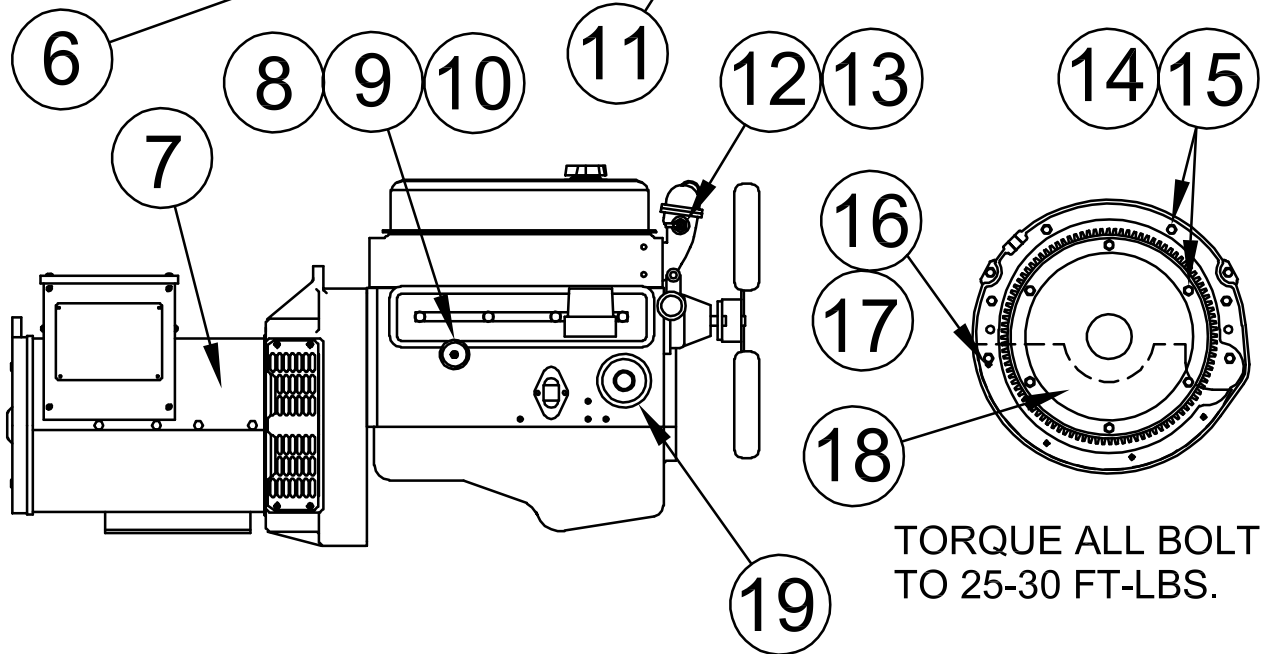
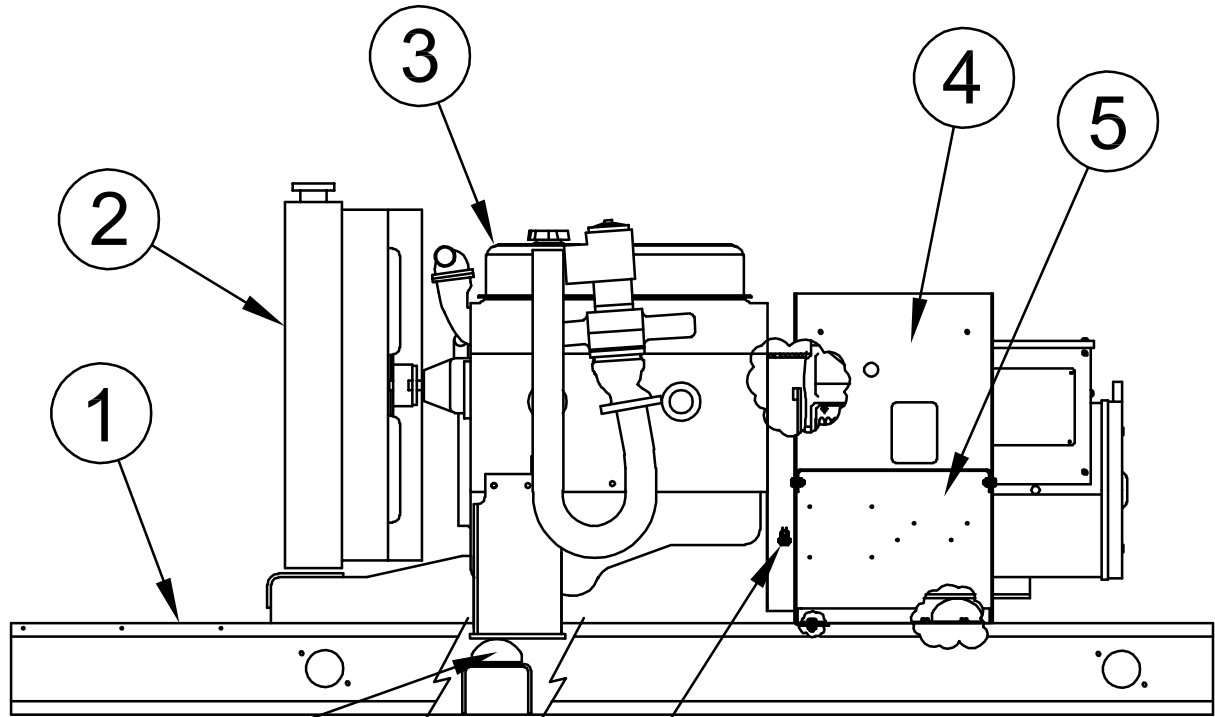

TORQUE ALL BOLTS
TO 25-30 FT-LBS.

REF #	PART NUMBER	QTY	DESCRIPTION
1	99381-008	1	Base Assembly
2	Provided by GM	1	Radiator
3	SEE TABLE	1	Engine GM 3.0 Liter
4	99057-002	1	Control Box Support Bracket
5	99057-004	1	Control Box Support Pedestal
6	98956-001	4	Shock Mount
7	SEE TABLE	1	Generator
8	99267-001	1	Oil Pressure Sender
9	22455-000	1	1/8" Coupling
10	92386-001	1	1/8" Pipe Nipple
11	350101-5	1	Magnetic Pick-up
12	99265-000	1	Temperature Sender
13	56372-000	1	1/2" M X 3/8" F Reducer
14	481-001	12	3/8" Lock Washer
15	96000-004	12	3/8"-16 X 1 1/2" Bolt
16	479-000	4*	1/4" Lock Washer
17	476-000	10*	1/4"-20 X 5/8" Bolt
18	350647	1*	Flywheel Cover
19	PF-25	1**	Oil Filter
NI	R46TS	4**	Spark Plug
NI	Not Illustrated		
*	PSS27LS/A Only		
**	AC Delco Part #		

MODEL #	PART #	DESCRIPTION
PSS27LS-3/A PSS27LS-4/A PSS27LS-17/A PSS27LS-18/A	350002-13	GM Engine 3.0 Liter Non SAE
PSS27LS-3/BNG PSS27LS-4/BNG PSS27LS-17/BNG PSS27LS-18/BNG	350775-1	GM Engine 3.0 Liter Non SAE with Electronic Governor

PSS27LS-3/BLP PSS27LS-4/BLP PSS27LS-17/BLP PSS27LS-18/BLP	350775-2	GM Engine 3.0 Liter Non SAE with Electronic Governor
PSS27LS-3/BLPG PSS27LS-4/BLPG PSS27LS-17/BLPG PSS27LS-18/BLPG	350775-3	GM Engine 3.0 Liter Non SAE with Electronic Governor

MODEL #	STAMFORD NEWAGE MODEL #	WINCO PART #
PSS27LS-3/BNG PSS27LS-3/BLP PSS27LS-3/BLPG	BCI184F 4-LEAD	350638-21
PSS27LS-4/BNG PSS27LS-4/BLP PSS27LS-4/BLPG PSS27LS-17/BNG PSS27LS-17/BLP PSS27LS-17/BLPG PSS27LS-18/BNG PSS27LS-18/BLP PSS27LS-18/BLPG	BCI184F 12-LEAD	350638-2

ELECTRICAL ASSEMBLY

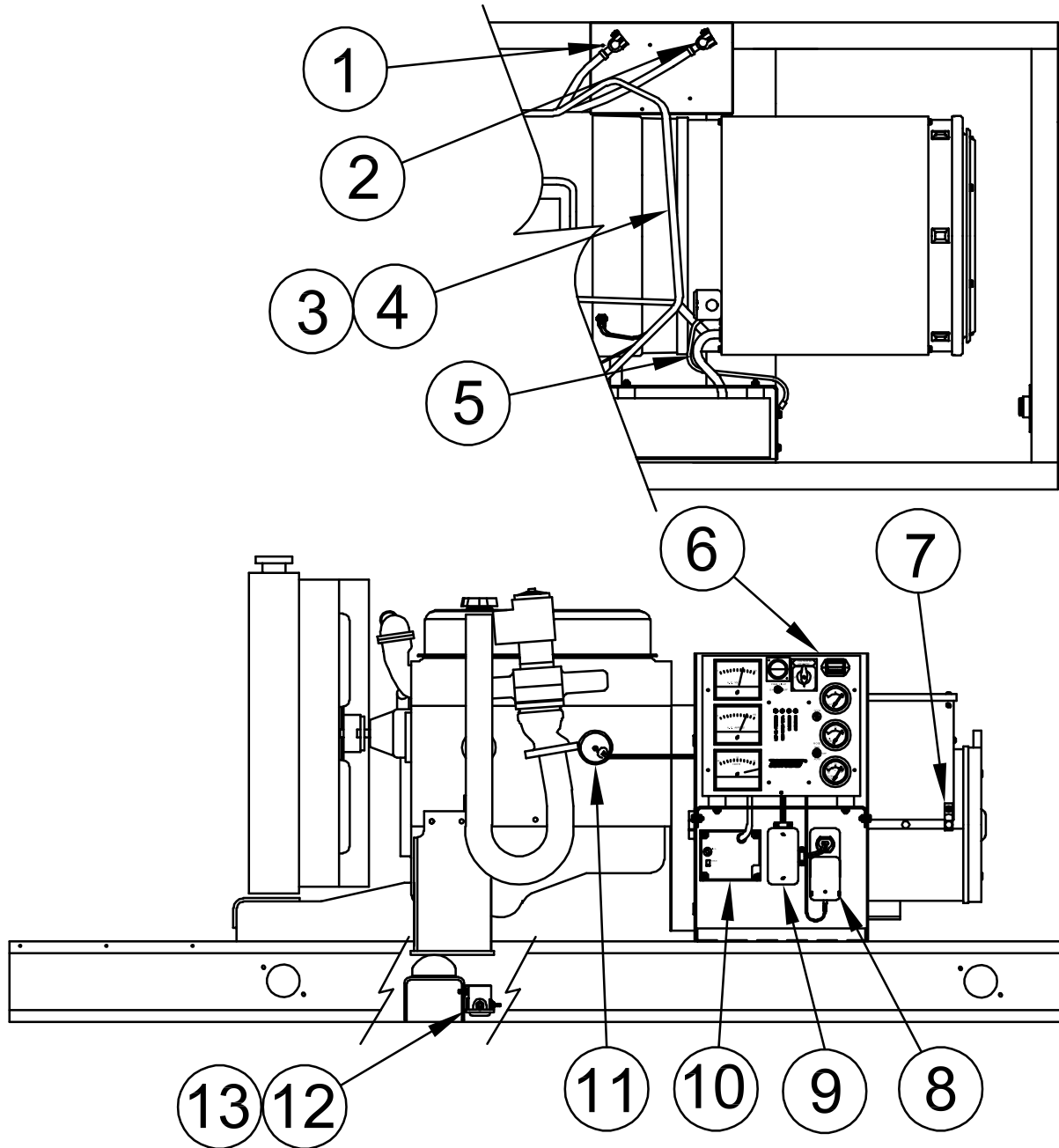

REF #	PART NUMBER	QTY	DESCRIPTION
1	53220-056	1	Positive (+) Battery Cable
2	53220-057	1	Negative (-) Battery Cable
3	99723-001	1	ECM Harness Assy. PSS27LS/A
4	99724-001	Ref.	ECM Harness Install. PSS27LS/A
3	99723-002	1	ECM Harness Assy. PSS27LS/B
4	99724-002	Ref.	ECM Harness Install. PSS27LS/B
5	Reference	1	AC Harness Installation
6	SEE TABLE	1	Control Box Assembly
7	48042-000	1	Ground Lug
8	99691-006	1	Battery Tender Assembly
9	15816-000	1*	Temperature Sensor
10	99673-001	1**	Governor Control
11	82505-004	1	Block Heater
12	80980-000	1	Start Solenoid
13	55440-000	2	Self-tapping Screw
*	Located inside the handy-box.		
**	PSS27LS/A only		

MODEL #	ASSEMBLY PART #
PSS27LS-3/A & /B	99685-004
PSS27LS-4/A & /B PSS27LS-17/A & /B	99685-008
PSS27LS-18/A & /B	99685-009

ENGINE CONTROL ASSEMBLY

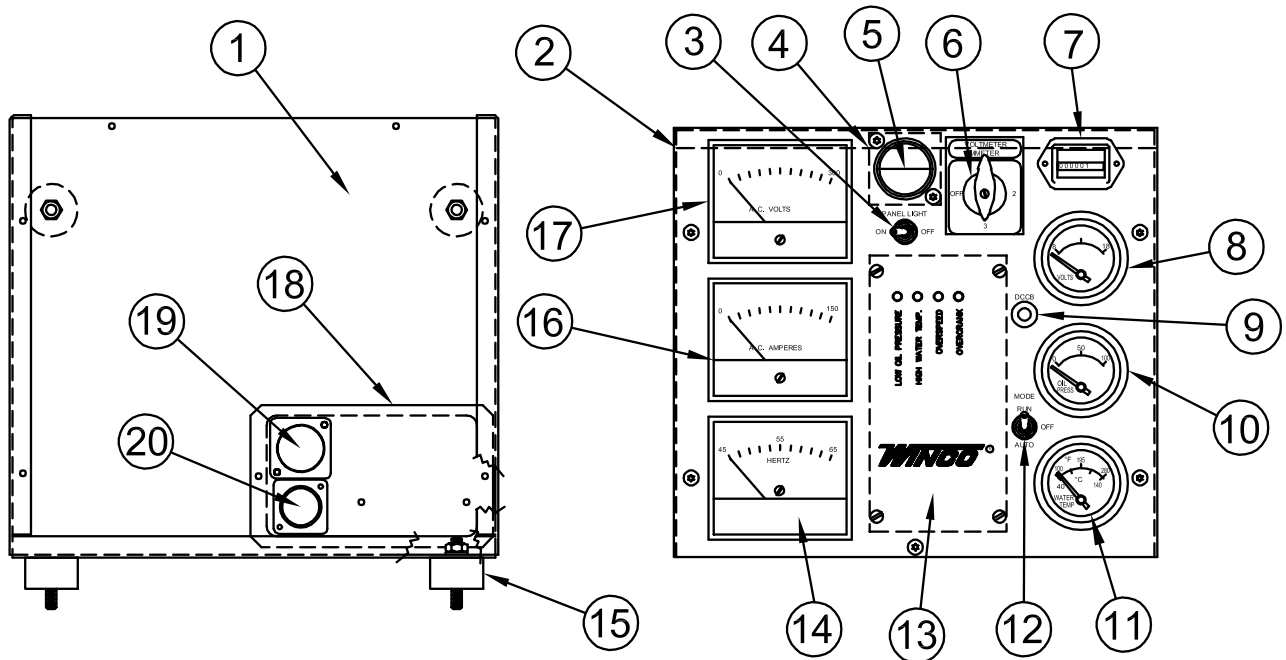

REF #	PART NUMBER	QTY	DESCRIPTION
1	99056-000	1	Rear Panel
2	99055-001	1	Front Panel
3	71215-001	1	SPST Toggle Switch
4	95807-000	1	License Light
5	99297-000	1	Backing Plate
6	SEE TABLE	1	Voltmeter, Ammeter Switch
7	58166-006	1	Running Time Meter
8	99268-000	1	DC Voltmeter
9	91286-000	1	15 Amp Breaker
10	99266-000	1	Oil Pressure Gauge
11	99264-000	1	Temperature Gauge
12	71216-001	1	DPDT Toggle Switch
13	64813-400	1	Engine Control Module
14	99272-002	1	Frequency Meter
15	71605-003	4	Shock Mount
16	SEE TABLE	1	Ammeter
17	SEE TABLE	1	Voltmeter
18	99343-000	1	Connector Backing Plate
19	96925-002	1	Connector
20	96925-005	1	Connector

MODEL #	PART NUMBER	DESCRIPTION
PSS27LS-3/B	99003-001	VOLTMETER, AMMETER SWITCH
PSS27LS-4/B PSS27LS-17/B PSS27LS-18/B	99003-000	VOLTMETER, AMMETER SWITCH

MODEL #	PART NUMBER	DESCRIPTION
PSS27LS-3/B	99271-002	AMMETER
PSS27LS-4/B PSS27LS-17/B	99271-001	AMMETER
PSS27LS-18/B	99271-008	AMMETER

MODEL #	PART NUMBER	DESCRIPTION
PSS27LS-18/B	99270-002	VOLTMETER
PSS27LS-3/B PSS27LS-4/B PSS27LS-17/B	99270-003	VOLTMETER

BATTERY TENDER ASSEMBLY

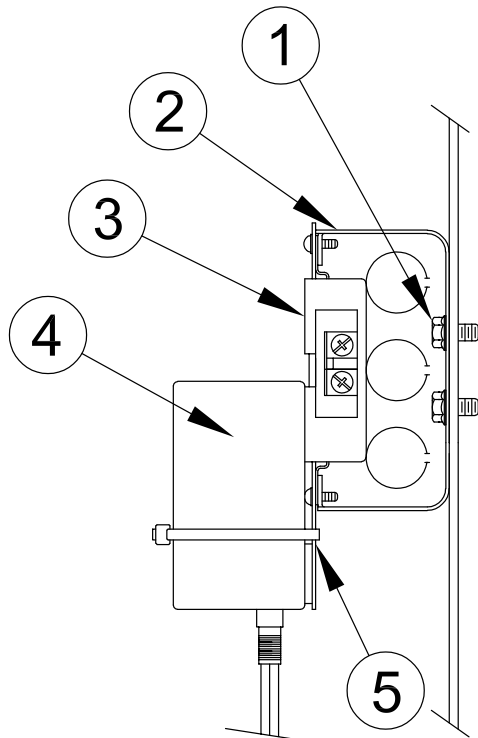

REF #	PART NUMBER	QTY	DESCRIPTION
1	52644-000	2	Self-tapping Screw
2	92789-000	1	Conduit Box
3	24749-000	1	Duplex Receptacle
4	16287-000	1	Battery Tender
5	59026-001	1	Recpt. Cover Plate

CONTROL PANEL WIRING DIAGRAM SINGLE PHASE

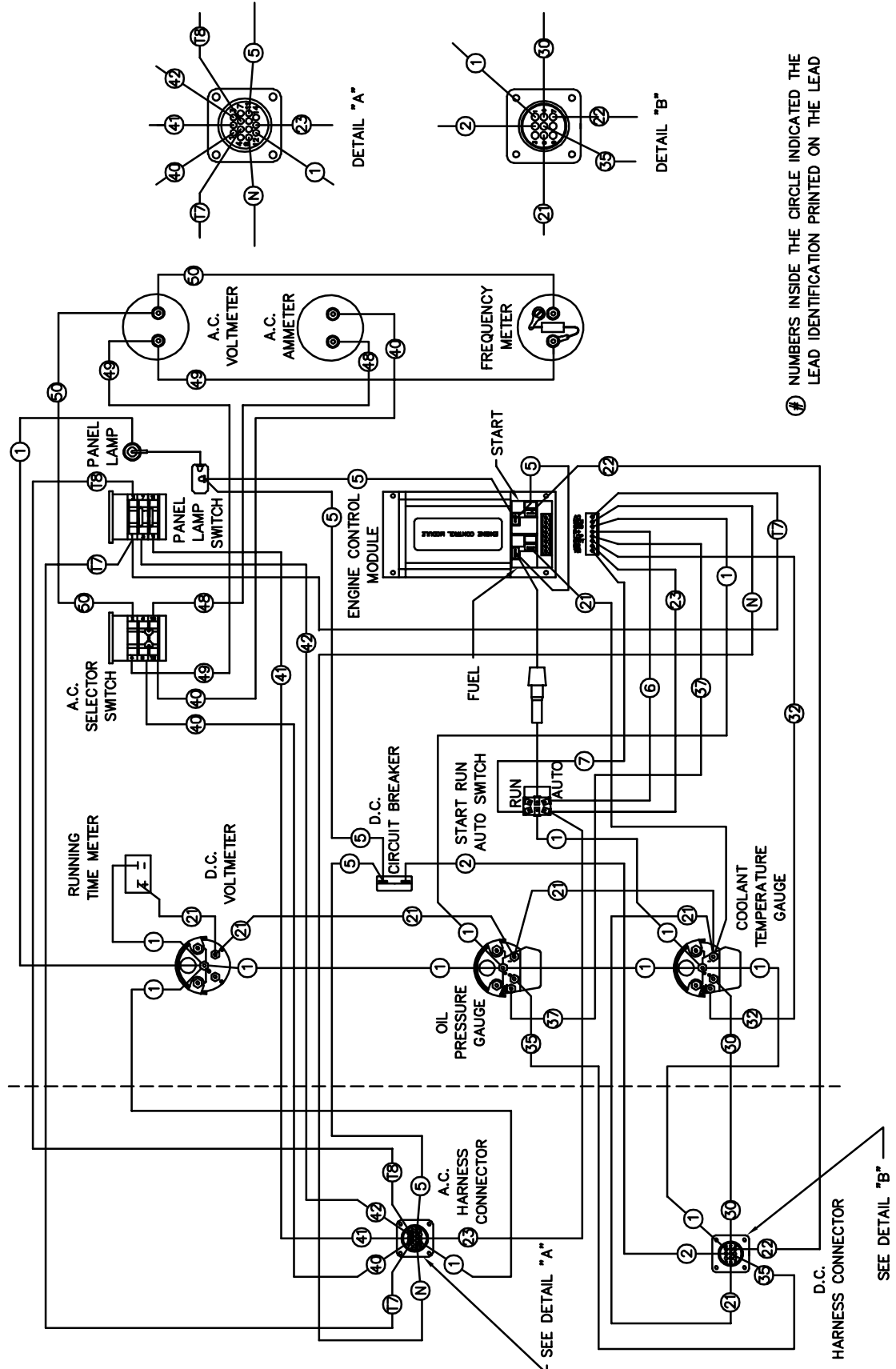

NUMBERS INSIDE THE CIRCLE INDICATED THE LEAD IDENTIFICATION PRINTED ON THE LEAD

CONTROL PANEL WIRING DIAGRAM THREE PHASE

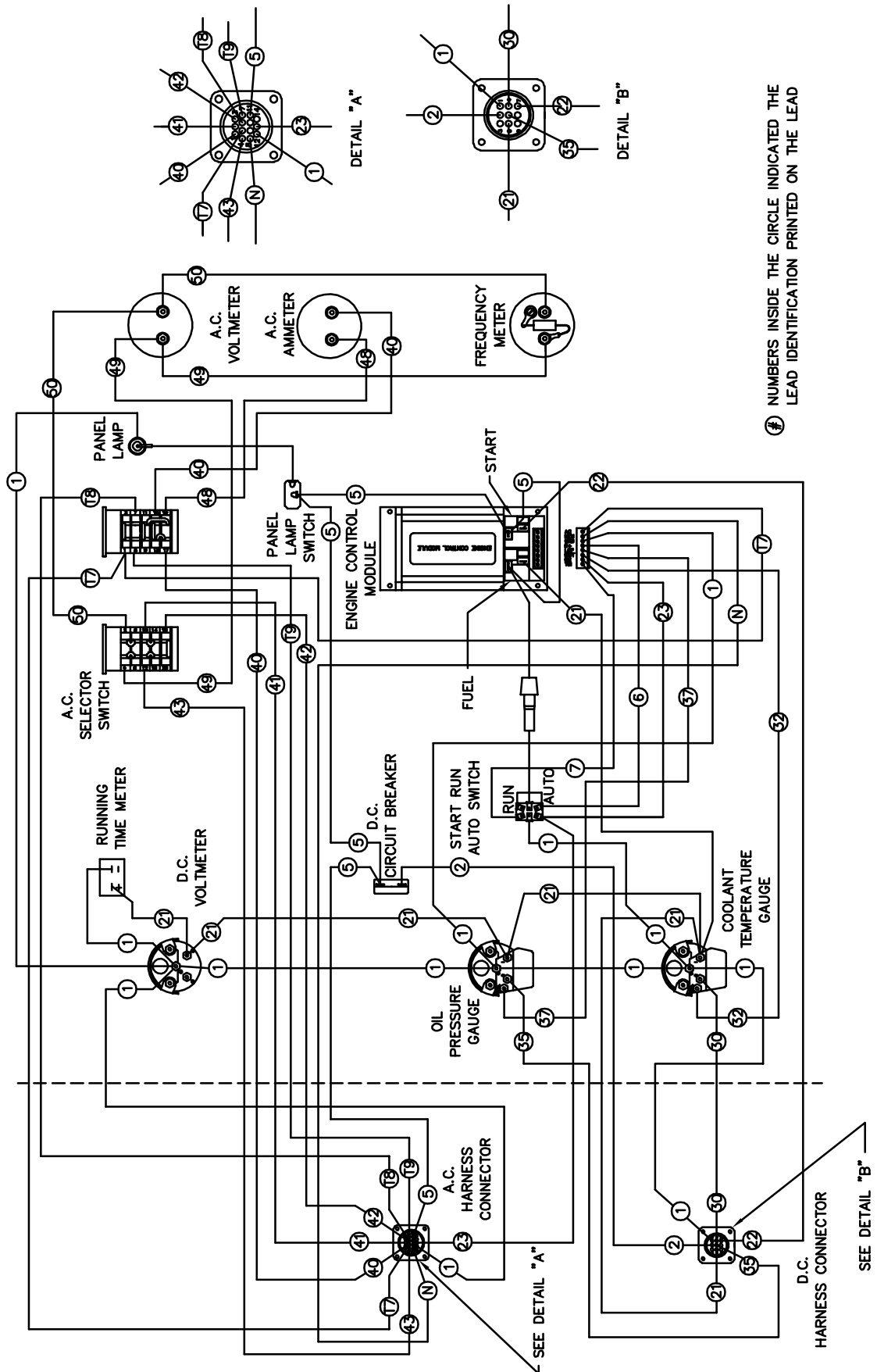

Ⓢ NUMBERS INSIDE THE CIRCLE INDICATED THE LEAD IDENTIFICATION PRINTED ON THE LEAD

SEE DETAIL "A"

SEE DETAIL "B"

AC WIRING INSTALLATION PSS27LS-3/A & /B

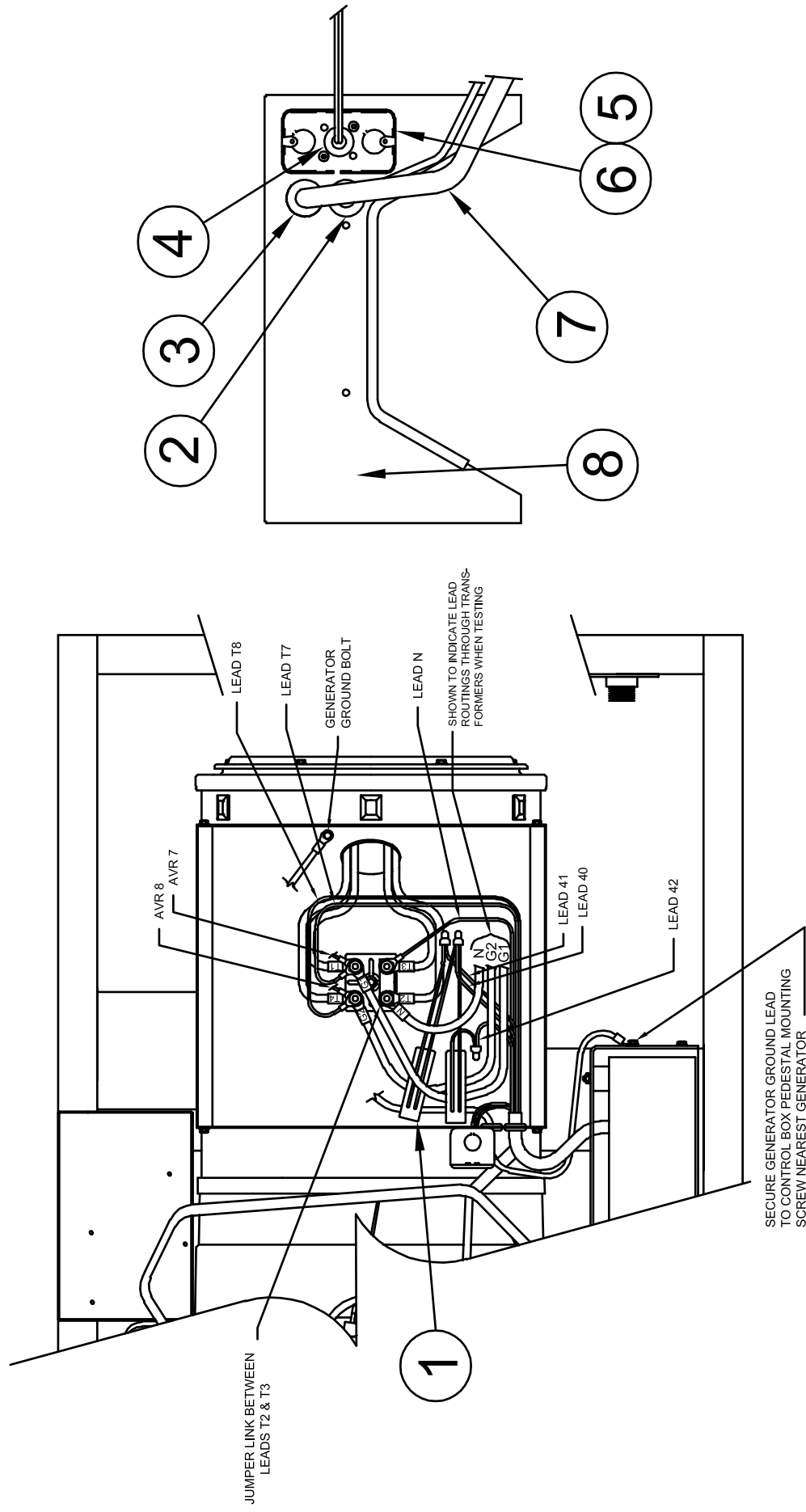

REF #	PART NUMBER	QTY	DESCRIPTION
1	SEE TABLE	2 or 3	Current Transformer
2	23917-000	1	Grommet
3	62486-000	1	Grommet
4	40730-000	1	Grommet
5	92789-000	1	Conduit Box
6	59026-000	1	Conduit Box Cover
7	SEE TABLE	1	AC Harness Assembly
8	99731-001	1	Panel
NI	350818	1	Voltage Regulator SX460
NI	Not Illustrated		

MODEL #	PART #	DESCRIPTION	QUANTITY
PSS27LS-3/A & /B	80124-004	150 to 5 Amp Current Transformer	2
PSS27LS-4/A & /B PSS27LS-17/A & /B	80124-003	100 to 5 Amp Current Transformer	3
PSS27LS-18/A & /B	80124-001	50 to 5 Amp Current Transformer	3

MODEL #	PART #
PSS27LS-3/A & /B	99347-002
PSS27LS-4/A & /B PSS27LS-17/A & /B PSS27LS-18/A & /B	99347-003

AC WIRING INSTALLATION PSS27LS-4/A & /B

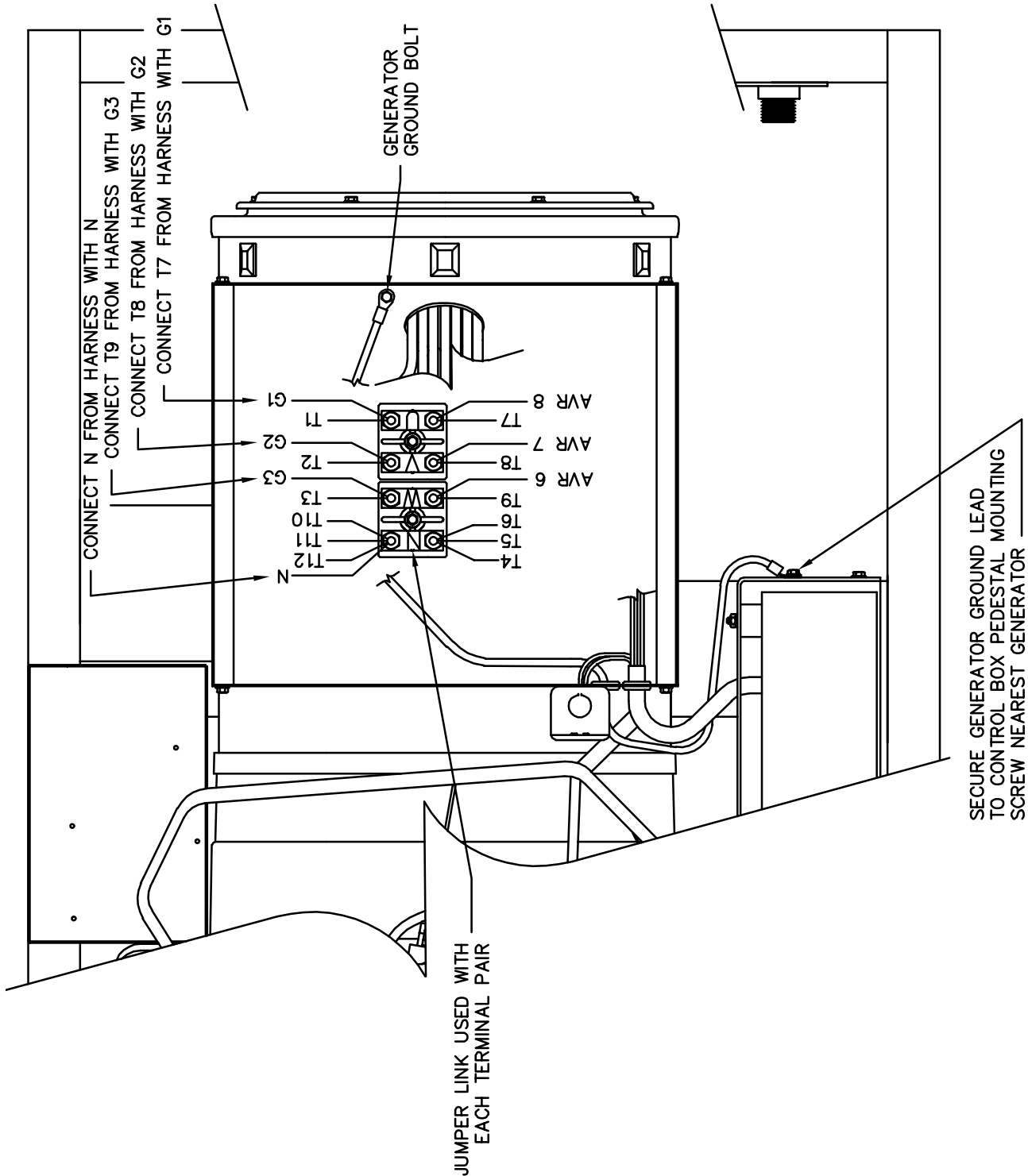

AC WIRING INSTALLATION PSS27LS-17/A & /B

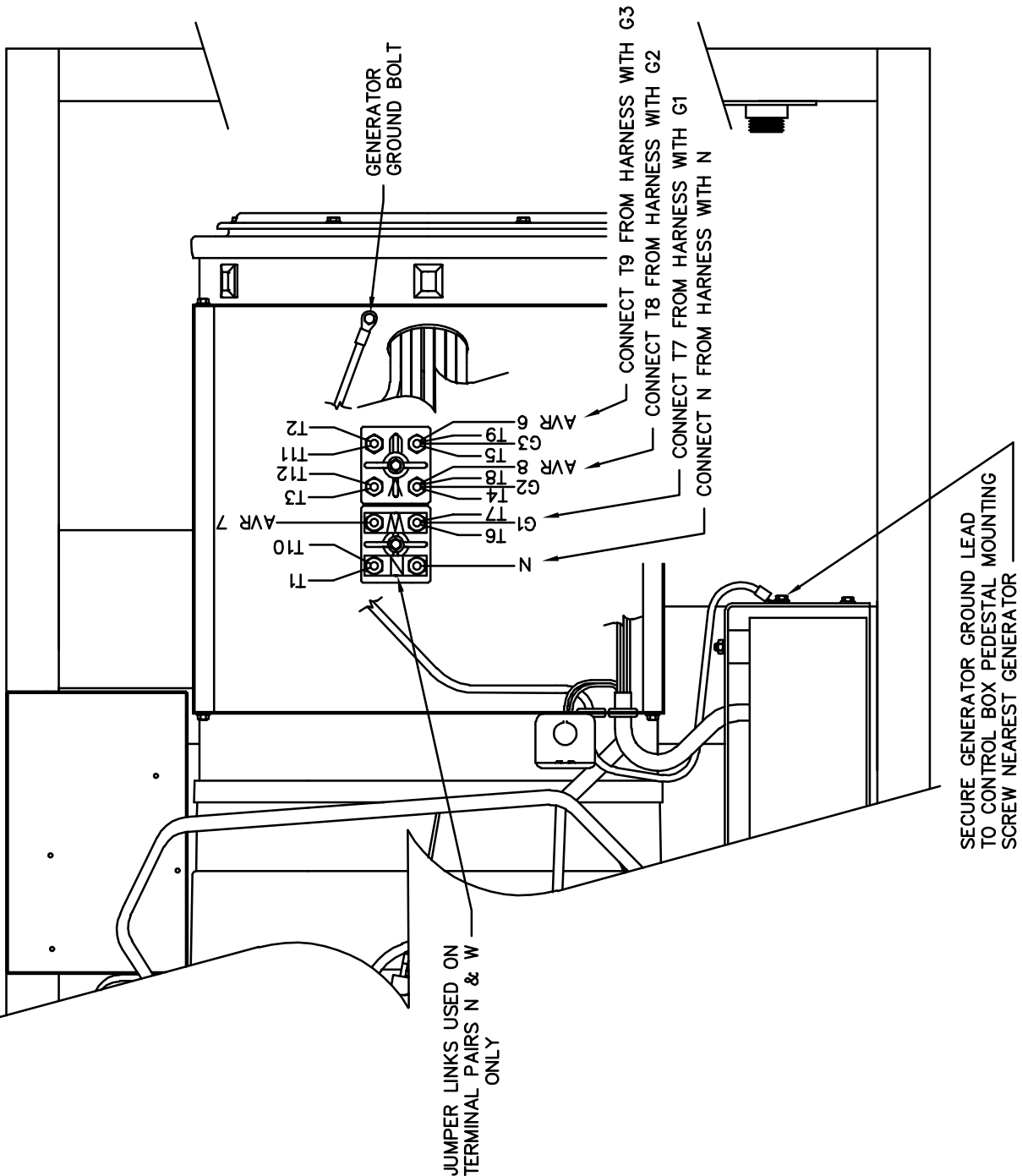

AC WIRING INSTALLATION PSS27LS-18/A & /B

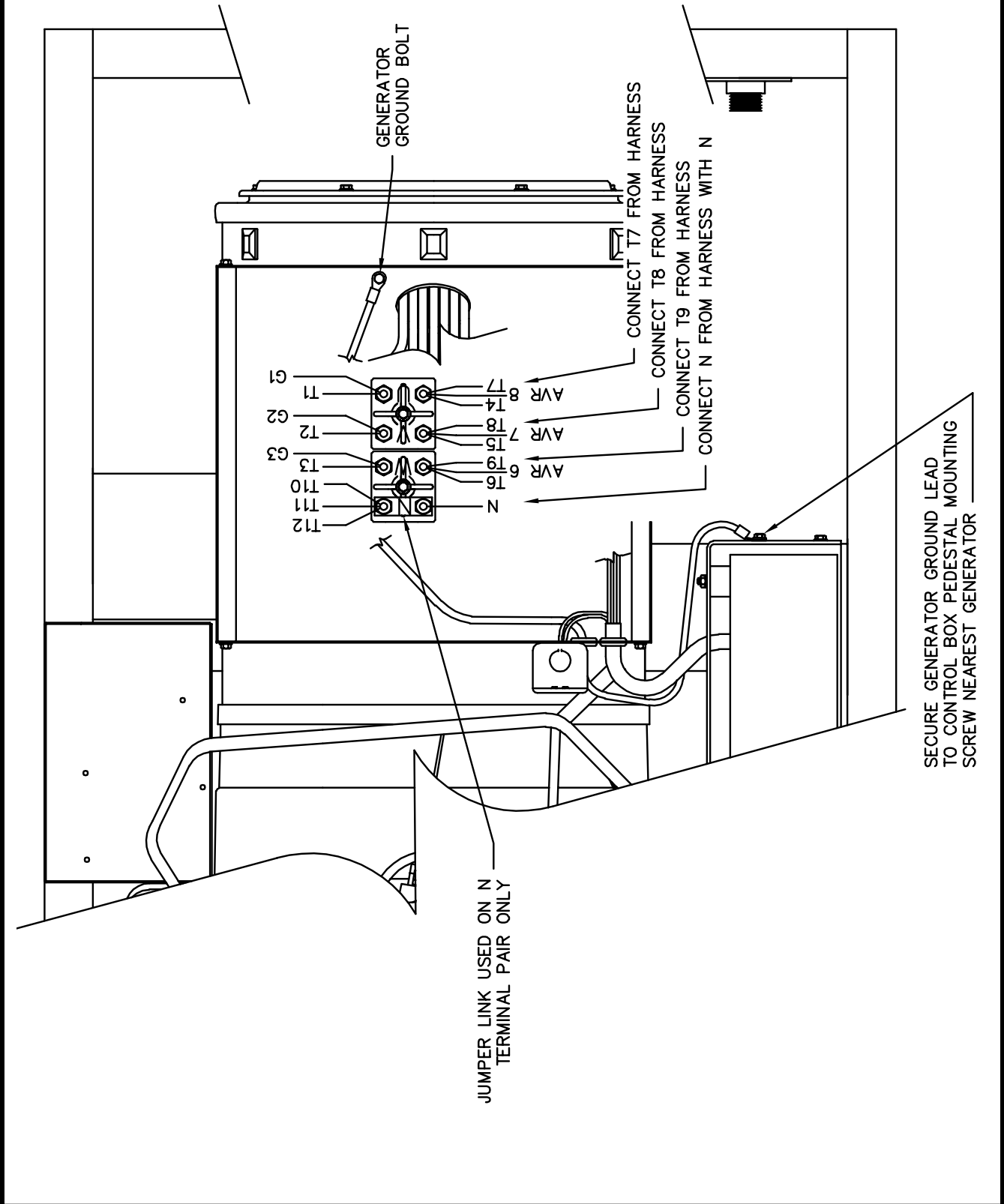

VAPOR FUEL SYSTEM ASSEMBLY PSS27LS/A

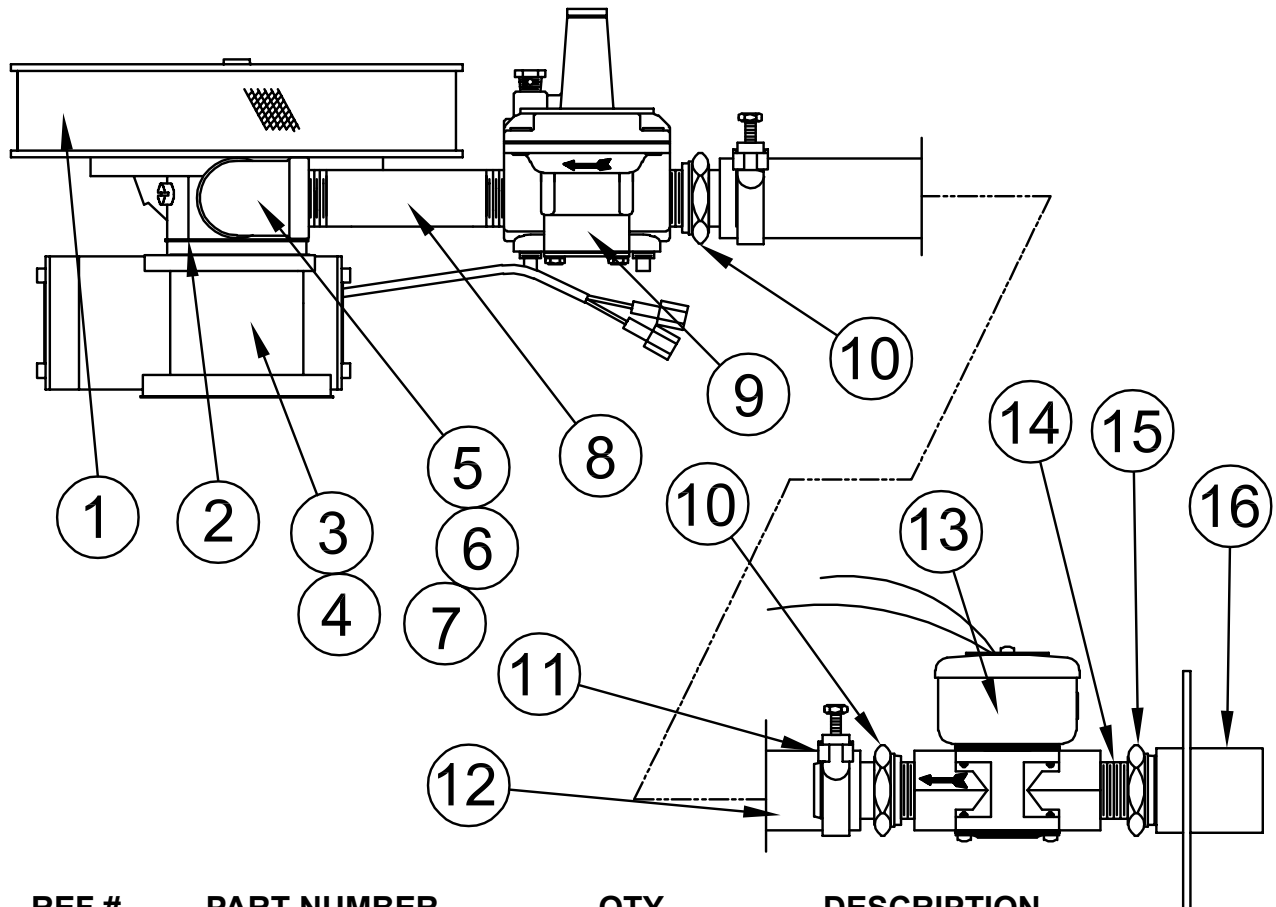

REF #	PART NUMBER	QTY	DESCRIPTION
1	F1-8	1*	Air Filter
2	350495	1	Fuel Mixer
3	350486	1	Governor Actuator
4	350136	1	1 1/2" Flange Gasket
5	50244-000	1	3/4" 90° Pipe Elbow
6	81075-000	1	1/2" F X 3/4" M Bushing
7	22768-000	1	1/2" Pipe Nipple
8	46819-000	1	3/4" X 3" Pipe Nipple
9	50248-000	1	Regulator
10	92388-004	2	3/4" NPT X 1" Hose Fitting
11	49409-006	42"	Hose
12	50245-000	2	Clamp
13	42942-000	1	Solenoid
14	22626-000	1	3/4" Pipe Nipple
15	81077-000	1	1" M X 3/4" F Bushing
16	99065-000	1	Fuel Inlet Weldment
*	Impco Part #		

VAPOR FUEL SYSTEM ASSEMBLY PSS27LS/B

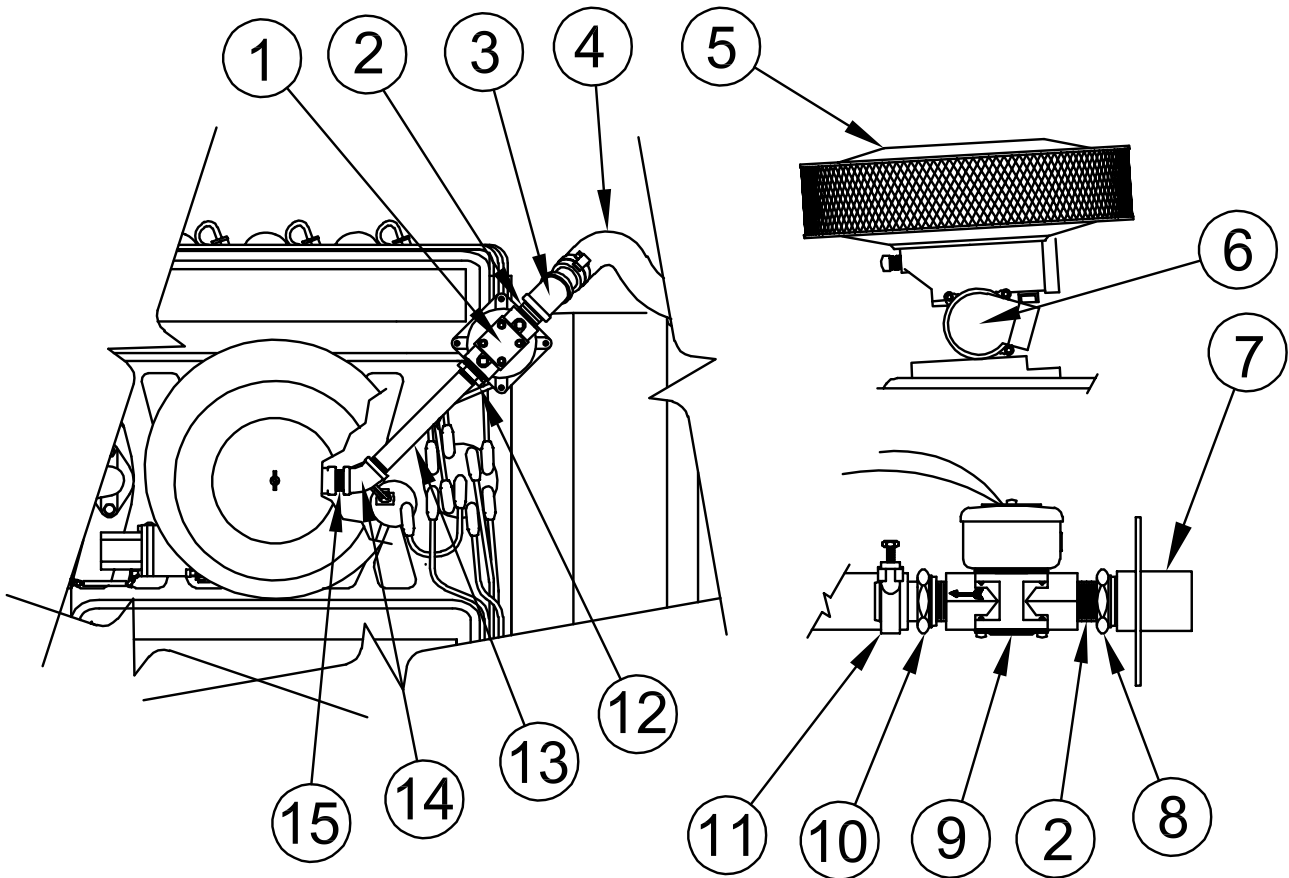

REF #	PART NUMBER	QTY	DESCRIPTION
1	50248-000	1	Regulator
2	22626-000	2	3/4" Pipe Nipple
3	56596-000	1	3/4" 45° Pipe Elbow
4	49409-015	50.5"	Hose
5	F1-8	1*	Air Filter
6	99526-005	1	"L" Series Governor
7	99065-000	1	Fuel Inlet Weldment
8	81077-000	1	1" M X 3/4" F Busing
9	42942-000	1	Solenoid
10	92388-004	2	3/4" X 1" Hose Fitting
11	50245-000	2	Hose Clamp
12	81075-000	1	3/4" X 1/2" Reducer
13	54074-001	1	3/4" X 3 1/2" Pipe Nipple
14	40072-000	1	1/2" 45° Pipe Elbow
15	22768-000	1	1/2" Pipe Nipple
*	Impco Part #		

LP LIQUID WITHDRAWAL ASSEMBLY

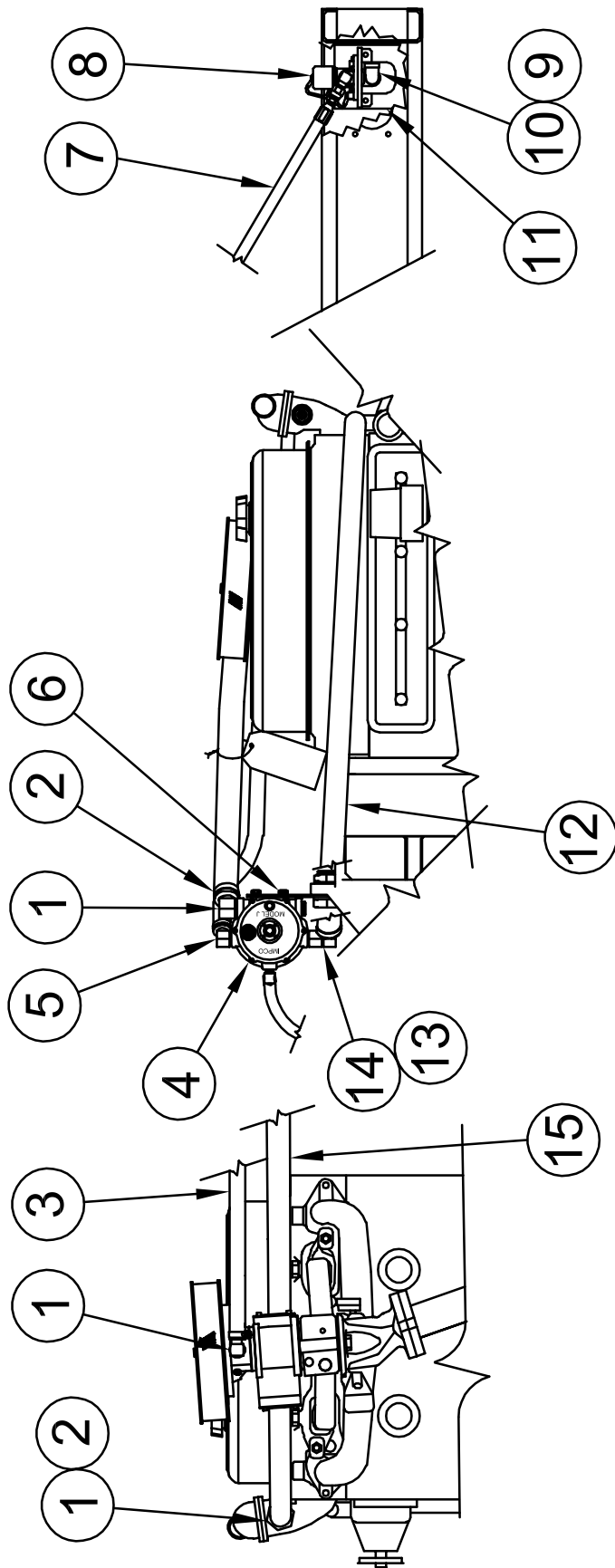

REF #	PART NUMBER	QTY	DESCRIPTION
1	92382-001	3	90° Elbow 1/2" NPT X 5/8" Hose
2	81018-005	5	Hose Clamp
3	93689-001	19"	5/8" I.D. Hose
4	81636-000	1	Converter-Regulator
5	92382-000	1	90° Elbow 3/8" NPT X 5/8" Hose
6	99364-001	1	Mounting Bracket
7	92940-005	1	Hose Assembly
8	99475-000	1	Solenoid
9	92533-000	1	90° 1/4" Pipe Elbow
10	81375-003	1	1/4" X 1 1/2" Pipe Nipple
11	99085-001	1	Fuel Cover Plate
12	93689-000	35"	3/4" I.D. Hose
13	92388-003	1	Hose Fitting
14	93734-000	1	1/2" X 3/8" Reducing Elbow
15	93689-001	28"	5/8" I.D. Hose

DECALS

REF #	PART NUMBER	QTY	DESCRIPTION
NI	15750-001	1	Ground Decal
NI	97813-000	3	Auto Start Warning
NI	15209-000	1	Warning Decal
NI	56596-000	1	Fuel Decal
NI	56597-000	1	Fuel Decal
NI	63941-001	1	Hot Surface Decal
NI	64891-001	1	Electrical Code Decal
NI	63941-003	1	Battery Warning Decal
NI	Not Illustrated		

EXHAUST ASSEMBLY

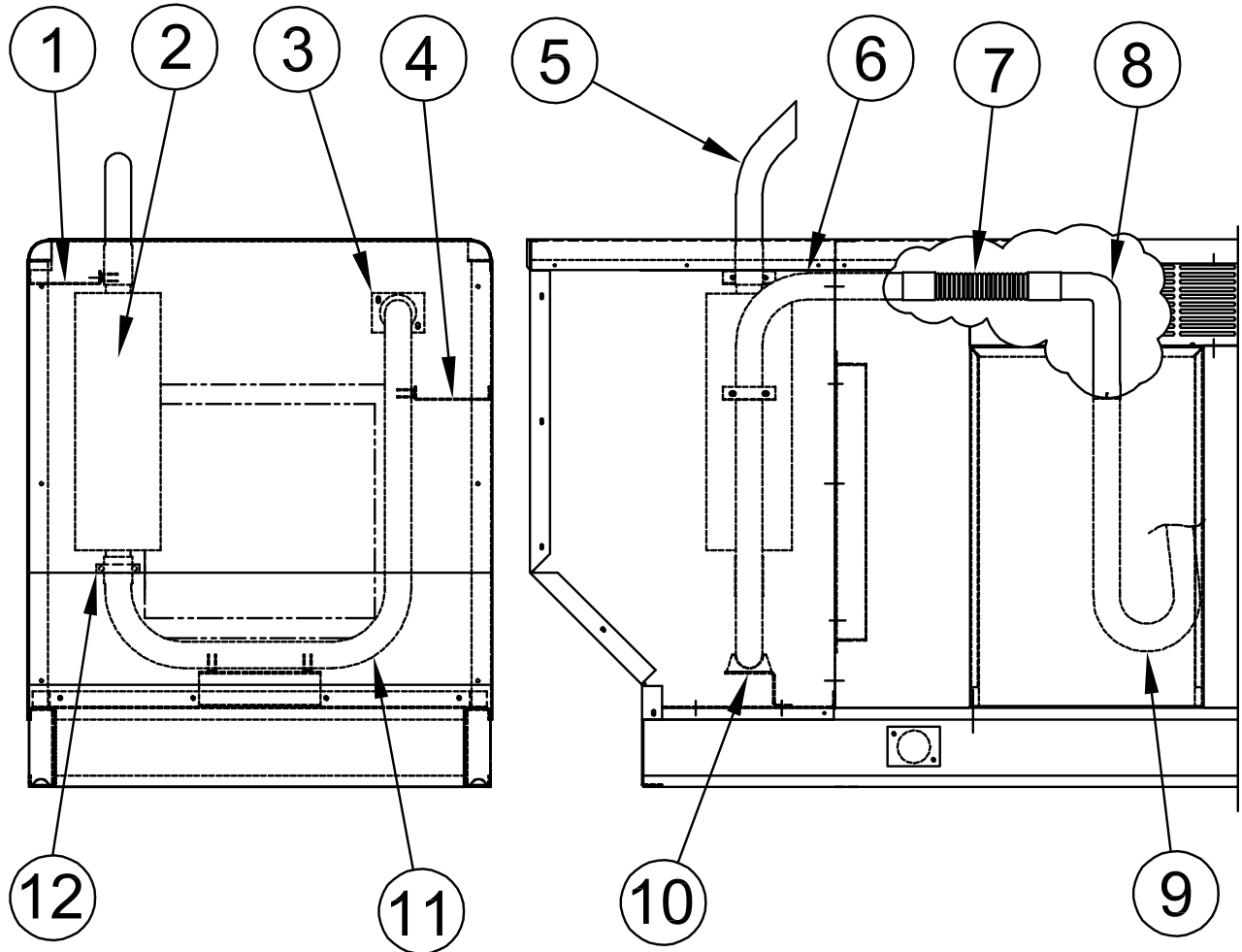

REF #	PART NUMBER	QTY	DESCRIPTION
1	99291-001	1	Exhaust Pipe Support
2	80519-001	1	Muffler
3	99060-001	1	Cover Plate
4	99291-003	1	Exhaust Pipe Support
5	99299-000	1	Tail Pipe
6	97761-007	1	90° Elbow 2"
7	64743-001	1	Flex Exhaust
8	97761-006	1	90° Elbow 2"
9	97274-000	25 FT	High Temperature Tape
10	99234-000	1	Exhaust Support
11	99298-001	1	Exhaust Pipe
12	93489-003	8	Muffler Clamp

HOUSING ASSEMBLY

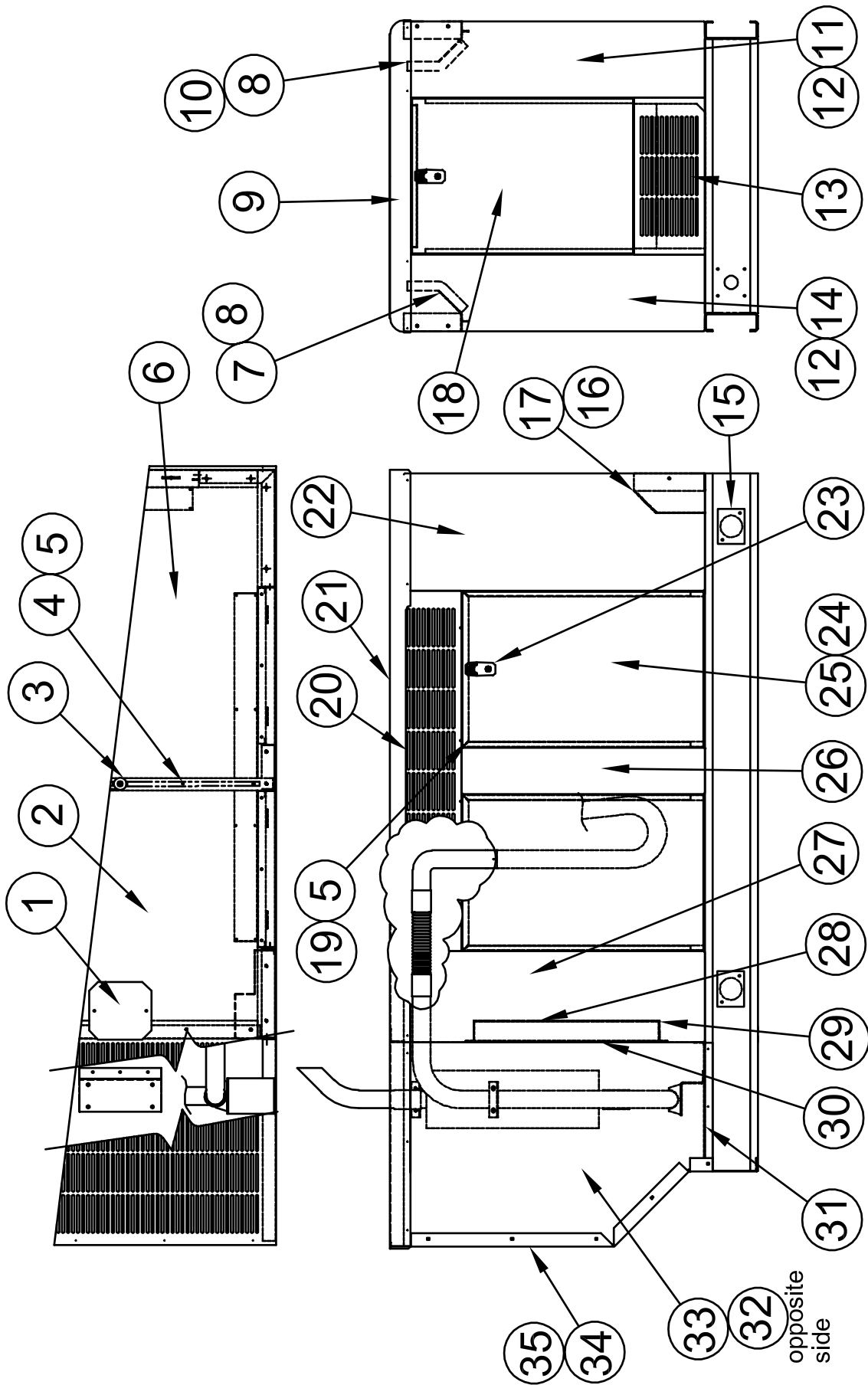

REF #	PART NUMBER	QTY	DESCRIPTION
1	62026-003	1	Cover Plate
2	99393-419	1	Foam Piece Front Roof
3	62825-011	1	Spacer
4	99225-001	1	Roof Support
5	62912-000	39.09 FT	Foam Strip
6	99393-405	1	Foam Piece Rear Roof
7	99393-420	1	Foam Piece
8	99103-001	2	Backing Plate
9	99391-000	1	Roof End
10	99393-408	1	Foam Piece
11	99067-001	1	Right Rear Corner Post
12	99393-410	2	Foam Piece
13	99100-000	1	Sill
14	99067-000	1	Left Rear Corner Post
15	99060-000	4	Cover Plate
16	99103-000	1	Backing Plate
17	99393-404	1	Foam Piece
18	15680-013	1	Back Door
19	99224-000	4	Door Jamb
20	99098-000	2	Sill
21	99086-005	1	Roof
22	99393-411	2	Foam Piece
23	95229-004	5	Door Latch
24	15680-009	4	Side Door
25	99393-412	4	Door Foam
26	99066-000	2	Mullion
27	99071-004	1	Housing Front
28	99708-000	2	Radiator Side Flange
29	99708-001	2	Radiator End Flange
30	92421-000	6.88 FT	1 1/2" Foam Strip
31	99223-000	1	Air Chamber Floor
32	99392-005	1	Right Side Extension
33	99392-004	1	Left Side Extension
34	99083-001	1	Front Panel
35	99393-406	1	Foam Piece

PSS27LS-3/B

HIGH VOLTAGE SINGLE PHASE

120/208-139/240 V. 60 HZ.

100/173- 115/200 V. 50 HZ.

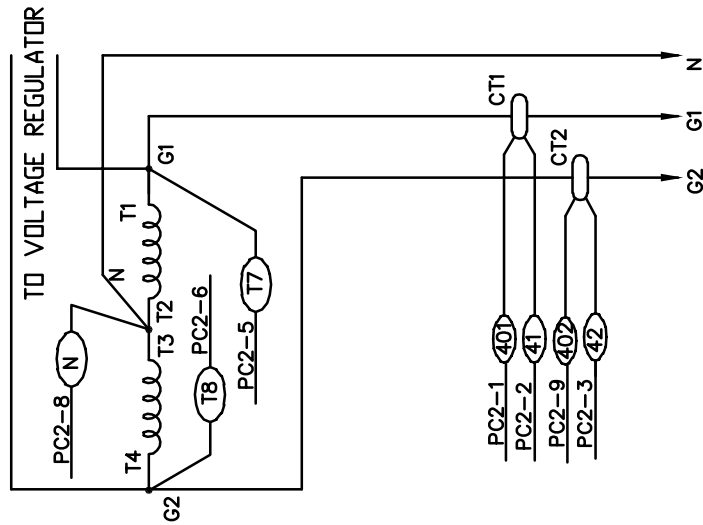

TO LOAD
(LINE CIRCUIT BREAKER,
TRANSFER SWITCH, ETC.)

AC WIRING SCHEMATICS

PSS27LS-18/B

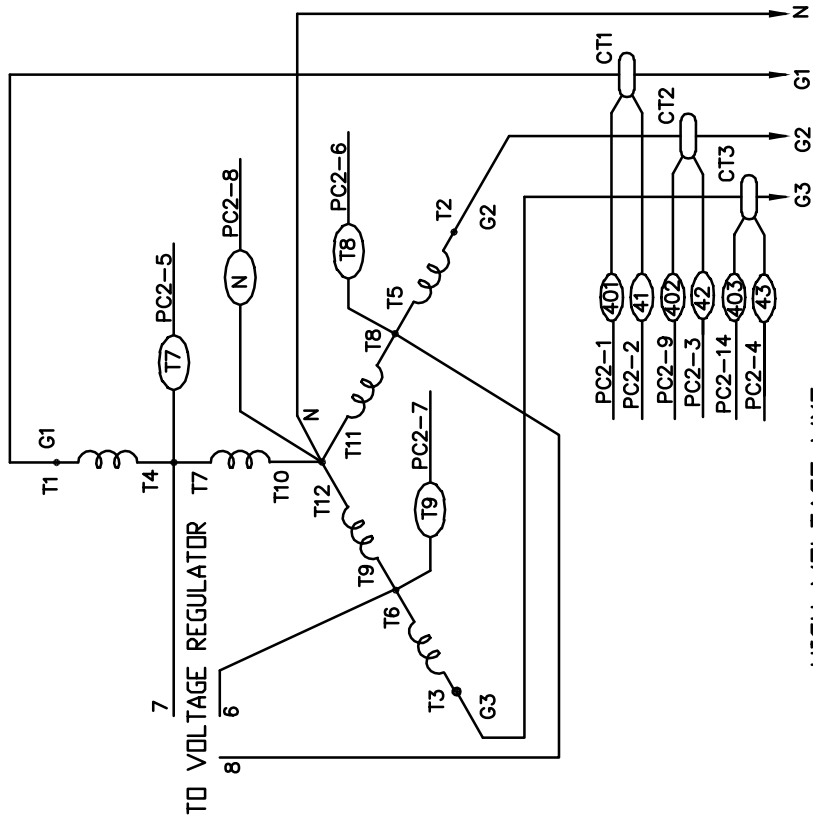

HIGH VOLTAGE WYE

240/416-277/480 V. 60 HZ.

219/380-231/400 V. 50 HZ.

TO LOAD
(LINE CIRCUIT BREAKER,
TRANSFER SWITCH, ETC.)

PSS27LS-4/B

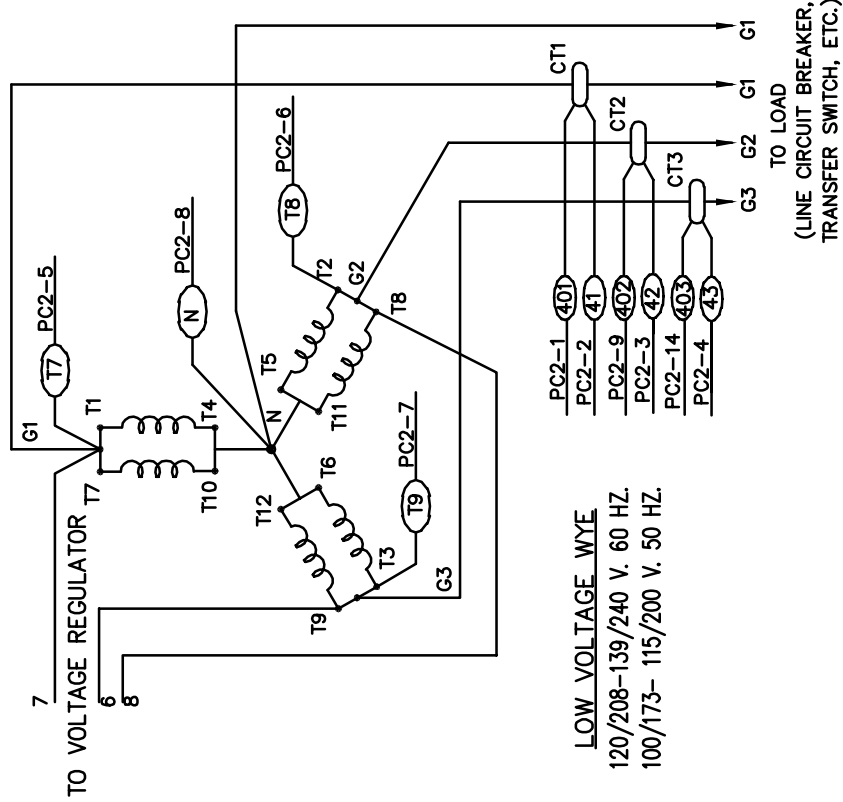

PSS27LS-17/B

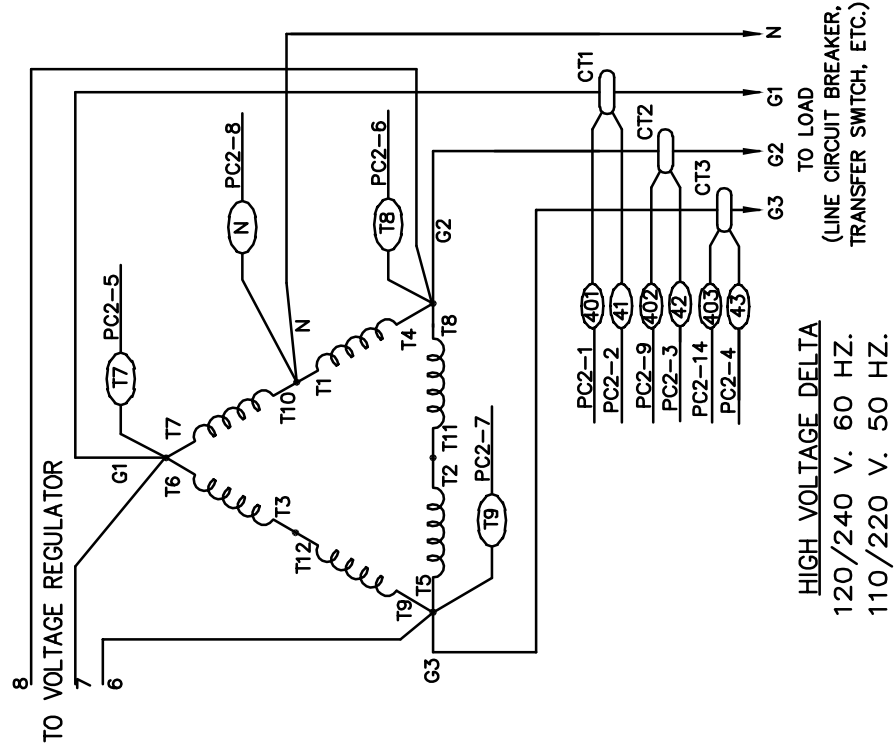

"BARBER COLMAN" SERIES GOVERNOR (PSS27LS/A)

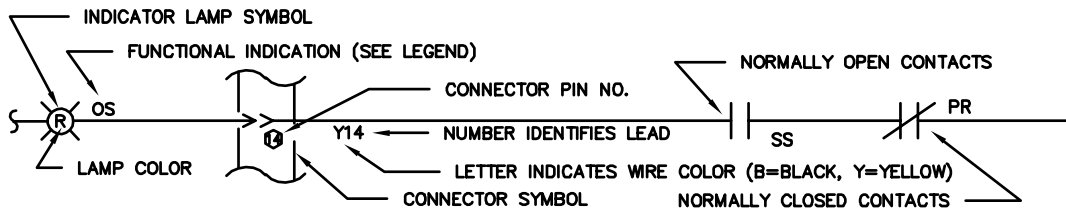
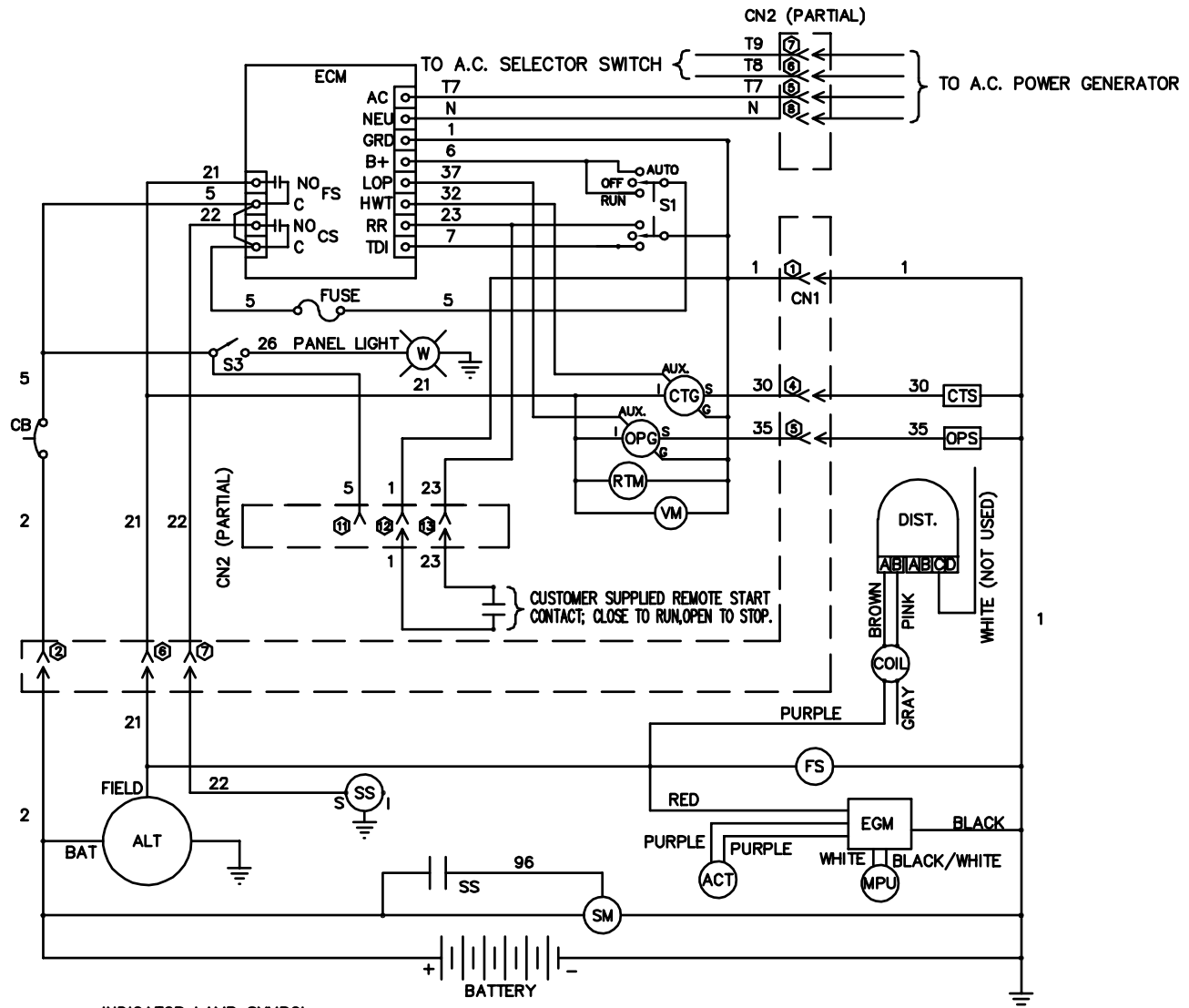

LEGEND

ALT	ALTERNATOR	MPU	MAGNETIC PICKUP UNIT
ACT	ELECTRONIC GOVERNOR ACTUATOR	OPG	OIL PRESSURE GAUGE
BC	BATTERY CHARGER	OPS	OIL PRESSURE SENDER
CB	CIRCUIT BREAKER	OS	OVERSPEED INDICATOR LAMP
CN1,CN2	WIRING HARNESS CONNECTORS	PR	PROTECTIVE RELAY, STARTER
CTG	COOLANT TEMPERATURE GAUGE	RTM	RUNNING TIME METER
CTS	COOLANT TEMPERATURE SENDER	S1	ENGINE START MODE SWITCH
ECM	ENGINE CONTROL MODULE	S3	PANEL ILLUMINATION LIGHT SWITCH
EGM	ELECTRONIC GOVERNOR MODULE	S4	ENGINE SHUTDOWN INDICATOR LAMP
FS	FUEL SOLENOID	SS	ENGINE STARTER MOTOR SOLENOID
GND	GROUND (CHASSIS OR FRAME)	SM	ENGINE STARTER MOTOR
		VM	D.C. VOLTMETER

DC WIRING SCHEMATIC

"LCS" SERIES GOVERNOR (ORIGINAL DESIGN PSS27LS/B)

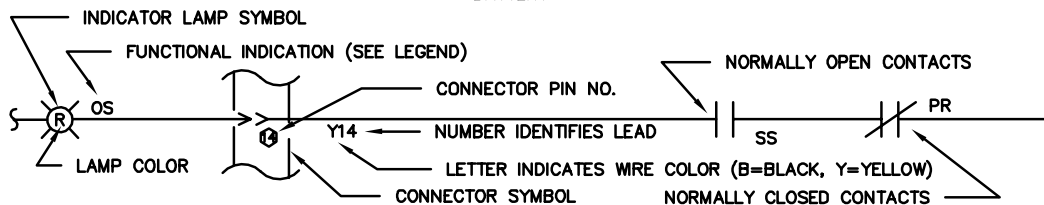
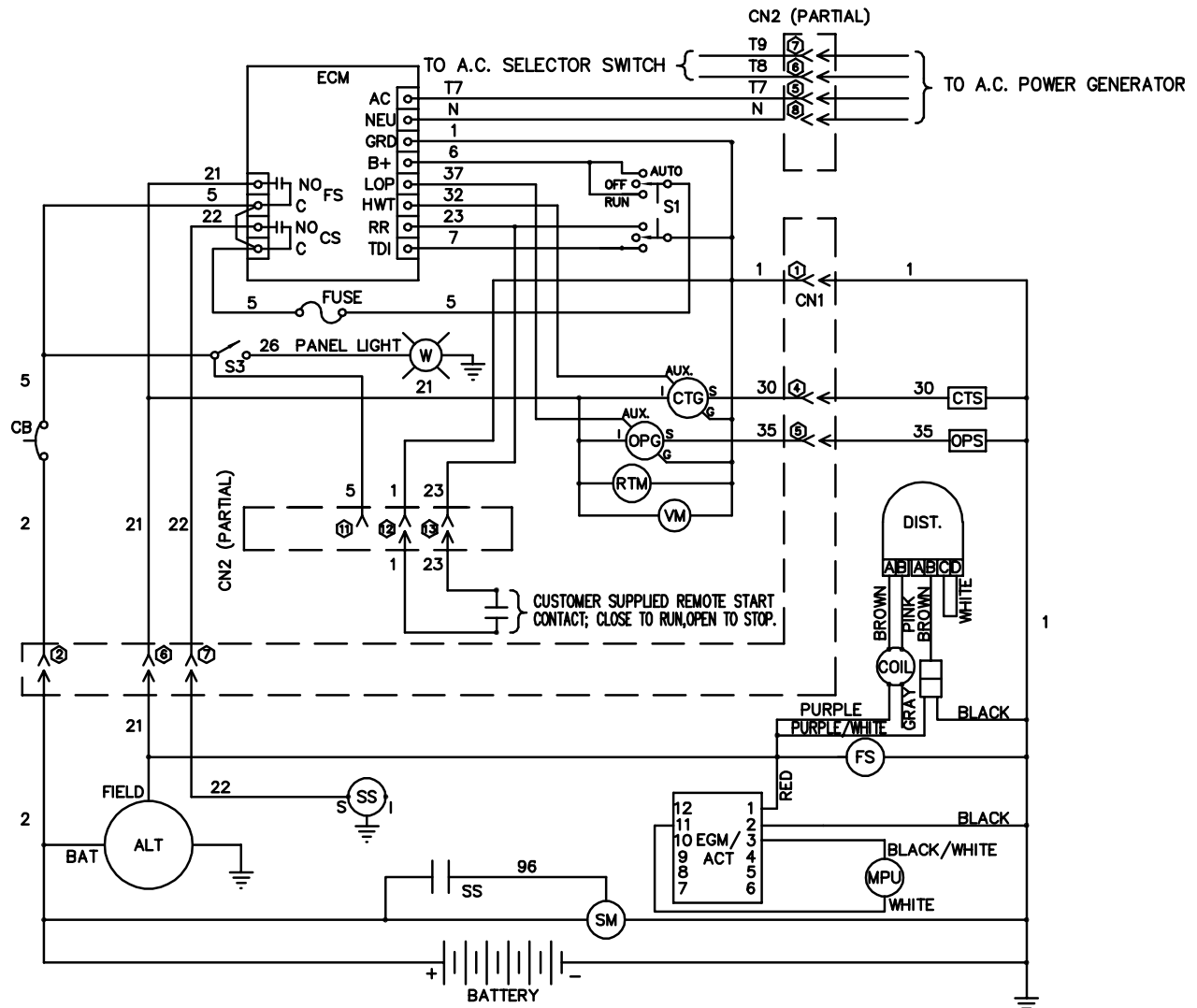

LEGEND

ALT	ALTERNATOR	OPG	OIL PRESSURE GAUGE
ACT	BATTERY CHARGER	OPS	OIL PRESSURE SENDER
BC	CIRCUIT BREAKER	OS	OVERSPEED INDICATOR LAMP
CB	CIRCUIT BREAKER	PR	PROTECTIVE RELAY, STARTER
CN1,CN2	WIRING HARNESS CONNECTORS	RTM	RUNNING TIME METER
CTG	COOLANT TEMPERATURE GAUGE	S1	ENGINE START MODE SWITCH
CTS	COOLANT TEMPERATURE SENDER	S3	PANEL ILLUMINATION LIGHT SWITCH
ECM	ENGINE CONTROL MODULE	S4	ENGINE SHUTDOWN INDICATOR LAMP
EGM/ACT	ELECTRONIC GOVERNOR MODULE / ACTUATOR	SS	ENGINE STARTER MOTOR SOLENOID
FS	FUEL SOLENOID	SM	ENGINE STARTER MOTOR
GND	GROUND (CHASSIS OR FRAME)	VM	D.C. VOLTMETER
MPU	MAGNETIC PICKUP UNIT		

DC WIRING SCHEMATIC

“L” SERIES GOVERNOR (WITH NEW GOVERNOR REPLACEMENT)

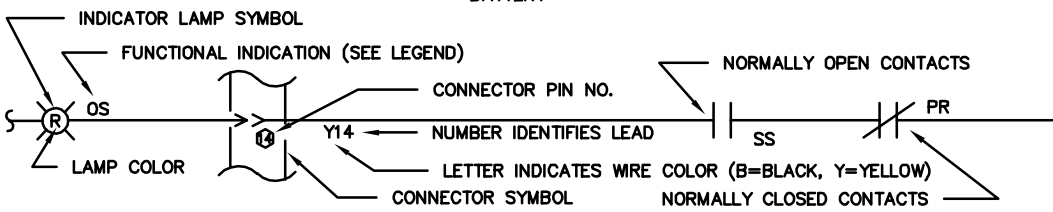
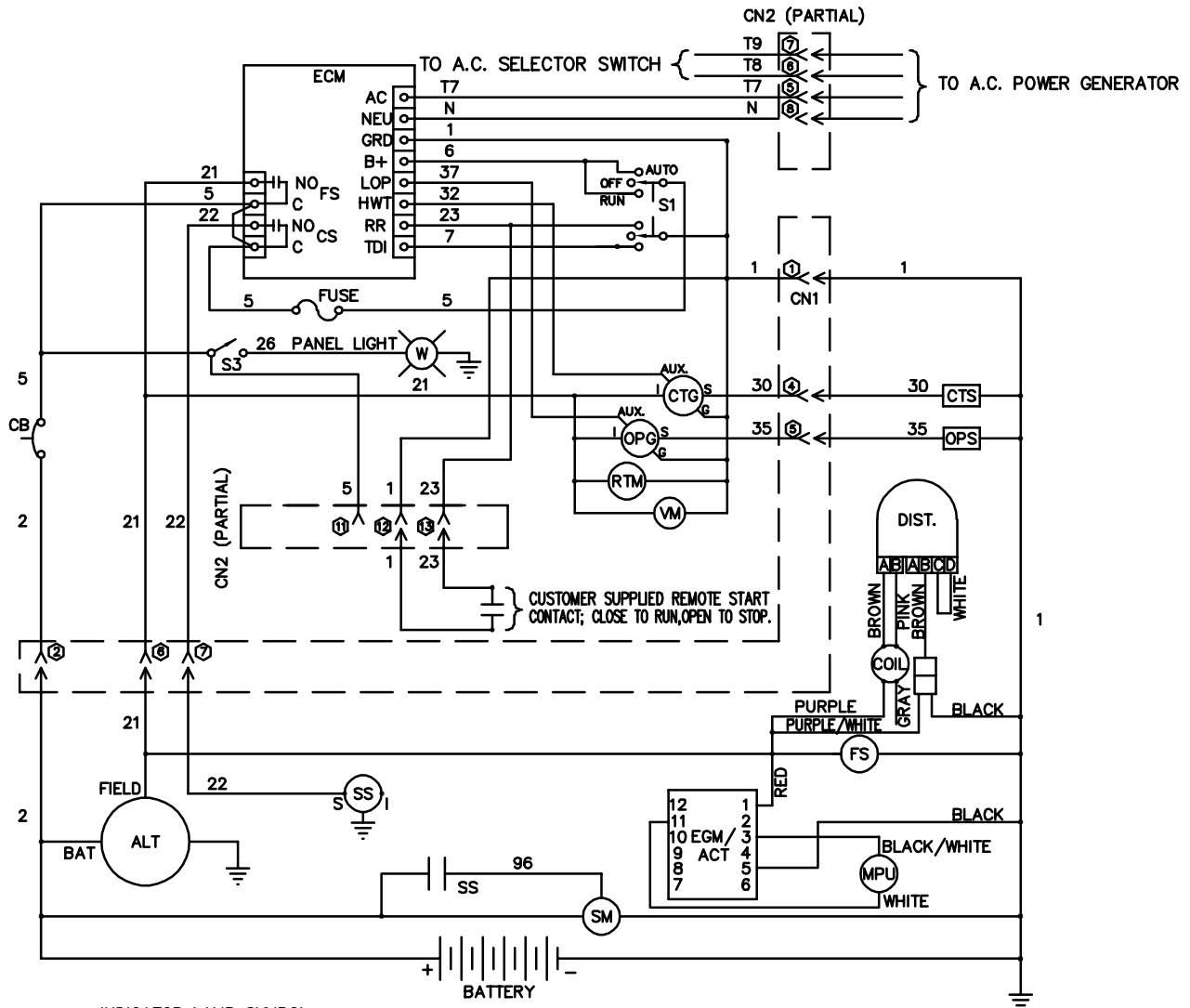

LEGEND

- | | | | |
|---------|---------------------------------------|-----|---------------------------------|
| ALT | ALTERNATOR | OPG | OIL PRESSURE GAUGE |
| ACT | ACTUATOR | OPS | OIL PRESSURE SENDER |
| BC | BATTERY CHARGER | OS | OVERSPEED INDICATOR LAMP |
| CB | CIRCUIT BREAKER | PR | PROTECTIVE RELAY, STARTER |
| CN1,CN2 | WIRING HARNESS CONNECTORS | RTM | RUNNING TIME METER |
| CTG | COOLANT TEMPERATURE GAUGE | S1 | ENGINE START MODE SWITCH |
| CTS | COOLANT TEMPERATURE SENDER | S3 | PANEL ILLUMINATION LIGHT SWITCH |
| ECM | ENGINE CONTROL MODULE | S4 | ENGINE SHUTDOWN INDICATOR LAMP |
| EGM/ACT | ELECTRONIC GOVERNOR MODULE / ACTUATOR | SS | ENGINE STARTER MOTOR SOLENOID |
| FS | FUEL SOLENOID | SM | ENGINE STARTER MOTOR |
| GND | GROUND (CHASSIS OR FRAME) | VM | D.C. VOLTMETER |
| MPU | MAGNETIC PICKUP UNIT | | |

DC WIRING SCHEMATIC