



ILLUSTRATED PARTS LIST

ULPSS60-3/A

ULPSS60-4/A

ULPSS60-17/A

ULPSS60-18/A

**WITH BASLER DGC-2020
ENGINE CONTROL**



225 S. CORDOVA AVE.
LECENTER, MN 56057
507-357-6821
SERVICE DEPT.
507-357-6831

GENERATOR ASSEMBLY

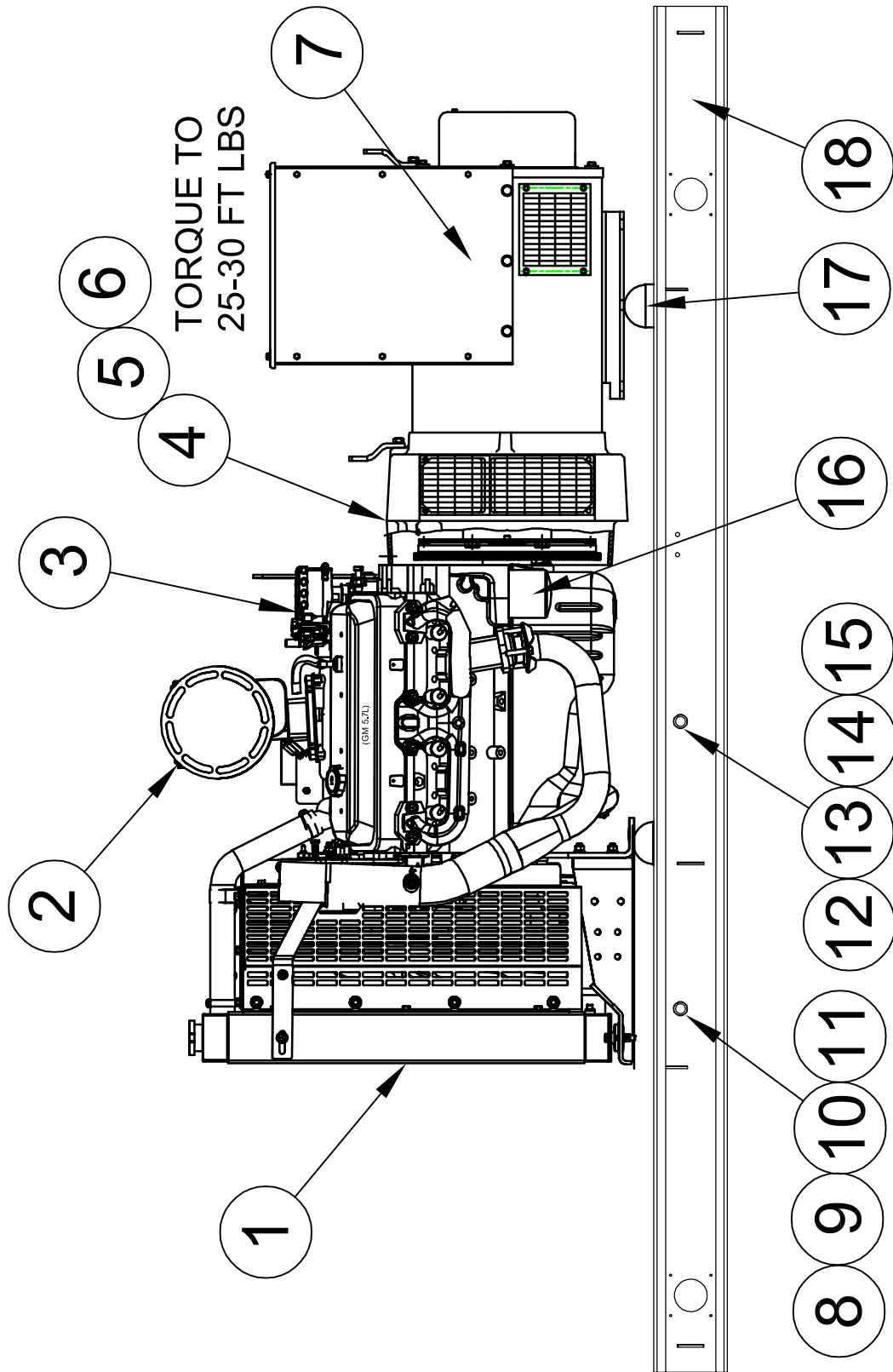

REF #	PART NUMBER	QTY	DESCRIPTION
1	Reference	1*	Radiator
2	F1-15	1**	Air Filter
3	351987-3	1	Engine GM 5.7 L
4	96000-004	12	3/8-16 X 1 1/2" Bolt
5	96000-002	8	3/8-16 X 2" Bolt
6	481-001	20	3/8" Lock Washer
7	SEE TABLE	1	Generator, Stamford Newage
8	93824-003	1	Petcock Valve
9	55505-000	1 FT	3/8" Hose
10	94319-008	2	Hose Fitting
11	93084-000	2	1/2" Pipe Plug
12	98906-009	1	Oil Drain Valve
13	99778-000	1	Adapter
14	55505-000	20"	3/8" Hose
15	62625-001	15"	Insulated Slewing
16	PF454	1***	Oil Filter, AC Delco
17	98956-001	4	Shock Mount
18	99309-061	1	Base Assembly
NI	99317-001	1	Battery Tray
NI	53220-013	1	Negative (-) Battery Cable
NI	53220-058	1	Positive (+) Battery Cable
NI	350818-2	1	Voltage Regulator AS440 UL
NI	R42LTS or R44LTS	8***	Spark Plug
NI	Not Illustrated		
*	GM Part		
**	Impco Part #		
***	AD Delco Part #		

MODEL #	STAMFORD NEWAGE MODEL #	WINCO PART #
ULPSS60-3/A	UCI224F1J 4-LEAD	351928-41
ULPSS60-4/A ULPSS60-17/A ULPSS60-18/A	UCI224F1L 12-LEAD	351928-4

ENGINE CONTROL ASSEMBLY

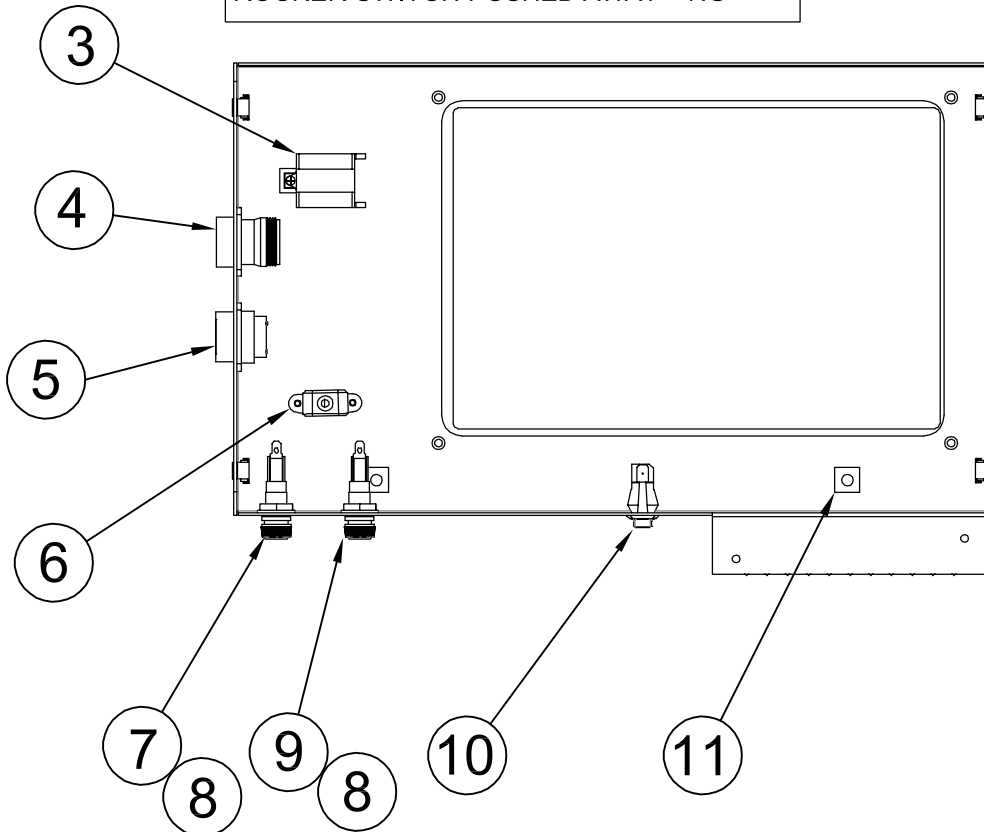
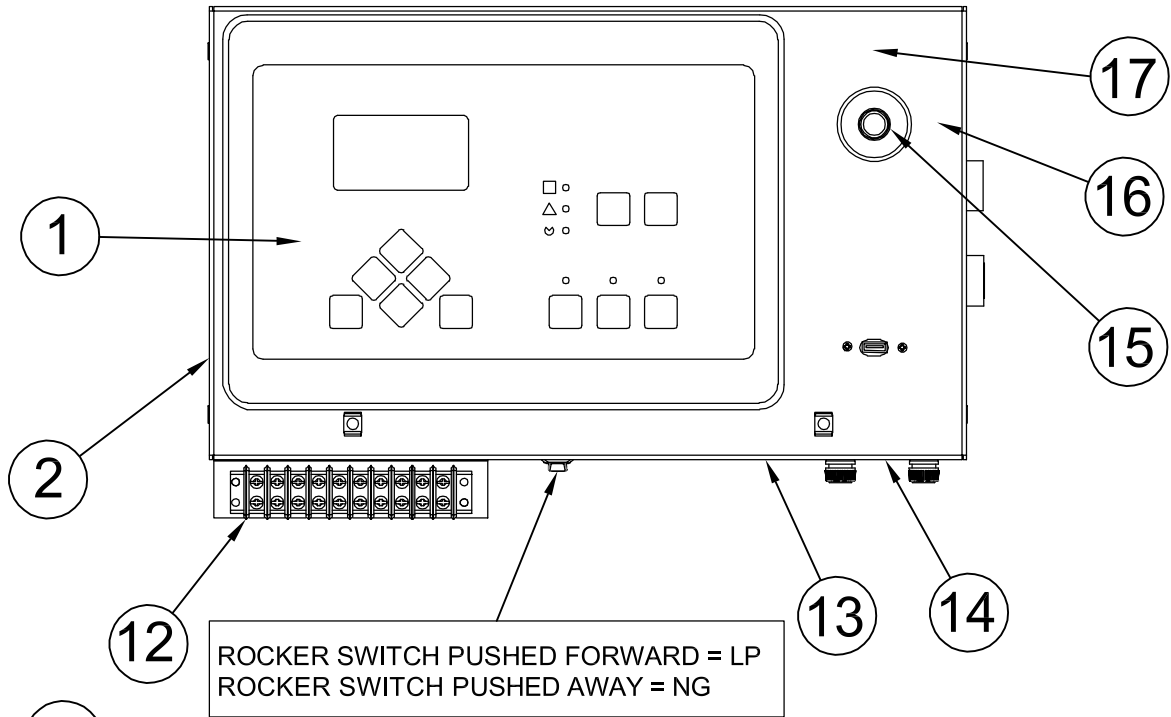

REF #	PART NUMBER	QTY	DESCRIPTION
1	351855-1	1	Basler DGC-2020 Control
2	99826-191	1	Basler Mount
3	99783-002	1	Emergency Stop Switch Contact
4	96925-006	1	16 Pin Connector
5	96925-002	1	14 Pin Connector
6	92884-000	1	USB Cable
7	95064-006	1	10 Amp Fuse
8	2489-001	2	Fuse Holder
9	95064-000	1	3 Amp Fuse
10	64089-000	1	Rocker Switch
11	92495-000	6	Tinnerman Nut
12	80623-006	1	10 Point Terminal Block
13	15983-008	1	3 Amp Fuse Decal
14	15983-006	1	10 Amp Fuse Decal
15	99783-001	1	Push-Pull Switch
16	63941-006	1	Emergency Stop Decal
17	63941-004	1	UL Warning Decal
NI	300542	1	3V Lithium Battery
NI	Not Illustrated		

BLOCK HEATER ASSEMBLY

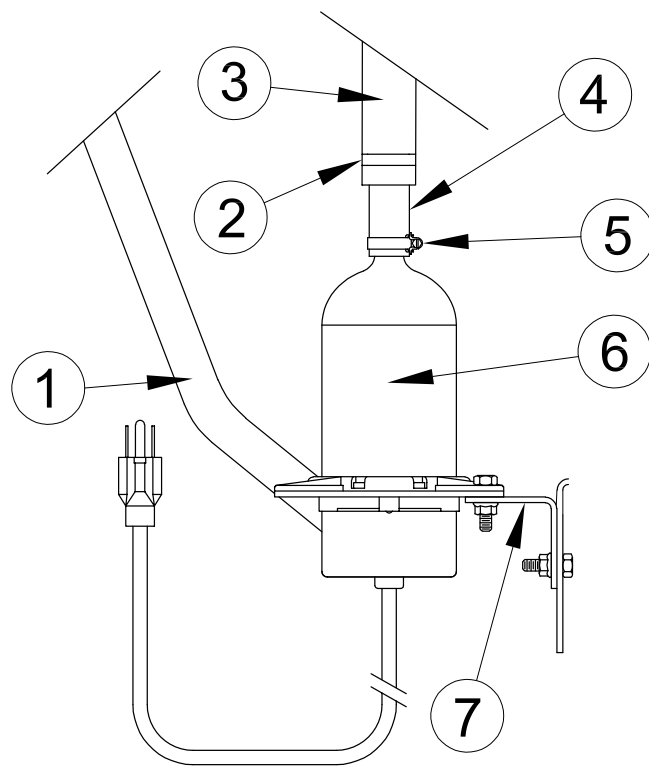

REF #	PART NUMBER	QTY	DESCRIPTION
1	93689-001	32"	5/8" Hose
2	Reference	4	Zip Tie
3	62625-002	3 FT	Insulated Sleeving
4	93689-001	26"	5/8" Hose
5	81018-005	4	Hose Clamp
6	80781-003	1	1000W 120V Tank Heater
7	Reference	1	Mounting Bracket

CONTROL CABINET ASSEMBLY

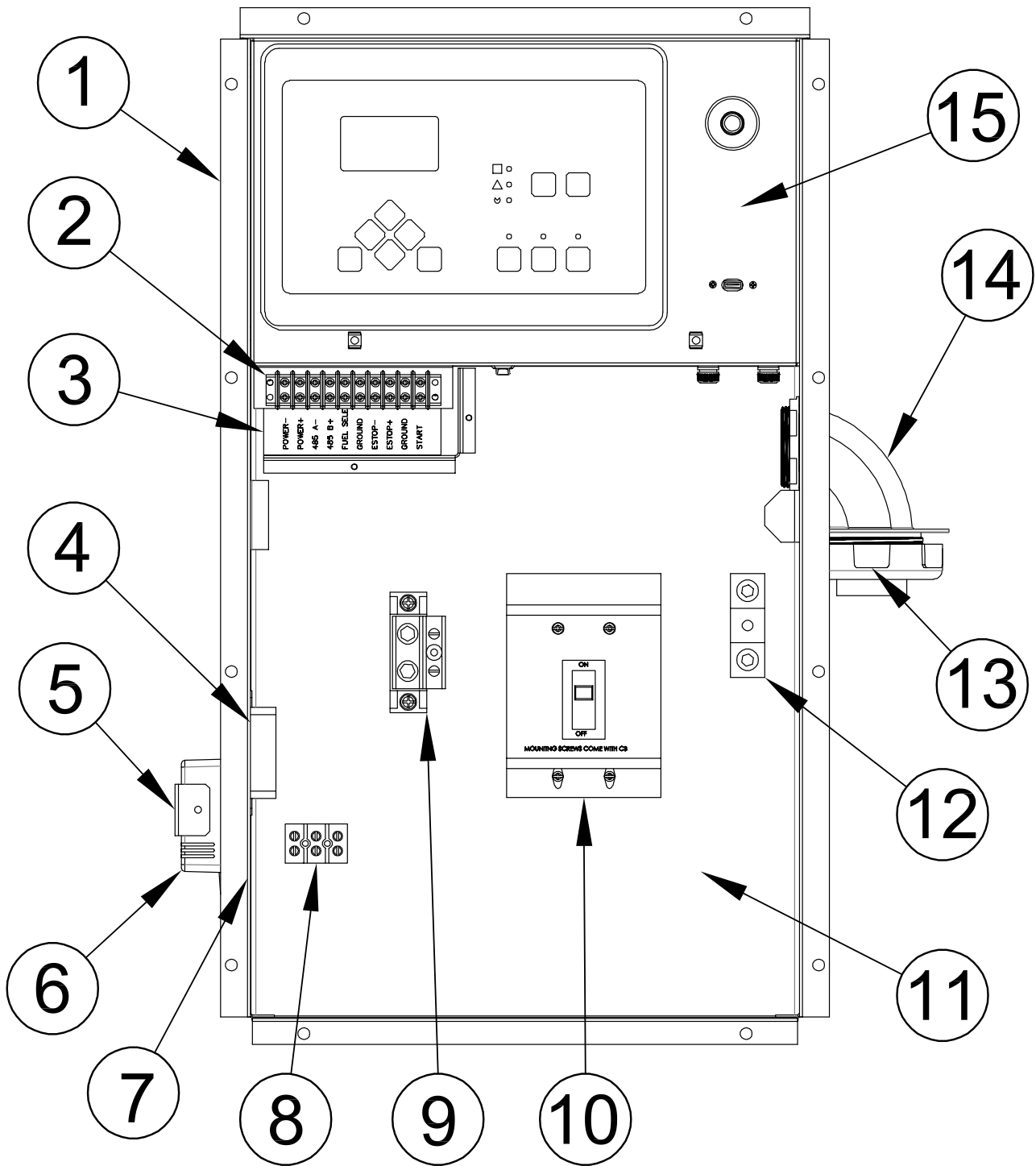

REF #	PART NUMBER	QTY	DESCRIPTION
1	99826-160	1	Control & Breaker Panel
2	63940-006	1	10 Point Terminal Block
3	99826-192	1	Terminal Block Box
4	24749-000	1	Duplex Receptacle
5	300308-410	1	Battery Tender Hold Down
6	16287-000	1	Battery Tender
7	15102-002	1	2 1/2" Hole Plug
8	51795-000	1	3 Point Terminal Block
9	350124-2	1	Neutral Block
10	SEE TABLE	1	Circuit Breaker
11	SEE TABLE	1	Breaker Cover Panel
12	58060-000	1	Ground Block
13	16522-001	2	2" Flexible Conduit Fitting
14	16523-000	1	2" Flexible Conduit
15	99777-022	1	Control Box Assembly

MODEL #	PART #	DESCRIPTION
ULPSS60-3/A	81094-007 99826-165	250 Amp 240Volt Breaker Circuit Breaker Panel
ULPSS60-4/A	81096-005 99826-165	200 Amp 240 Volt Breaker Circuit Breaker Panel
ULPSS60-17/A	81096-004 99826-165	175 Amp 3 Pole 240 Volt Breaker Circuit Breaker Panel
ULPSS60-18/A	81098-028 99826-167	90 Amp 3 Pole 600 Volt Breaker Circuit Breaker Panel

EXHAUST ASSEMBLY

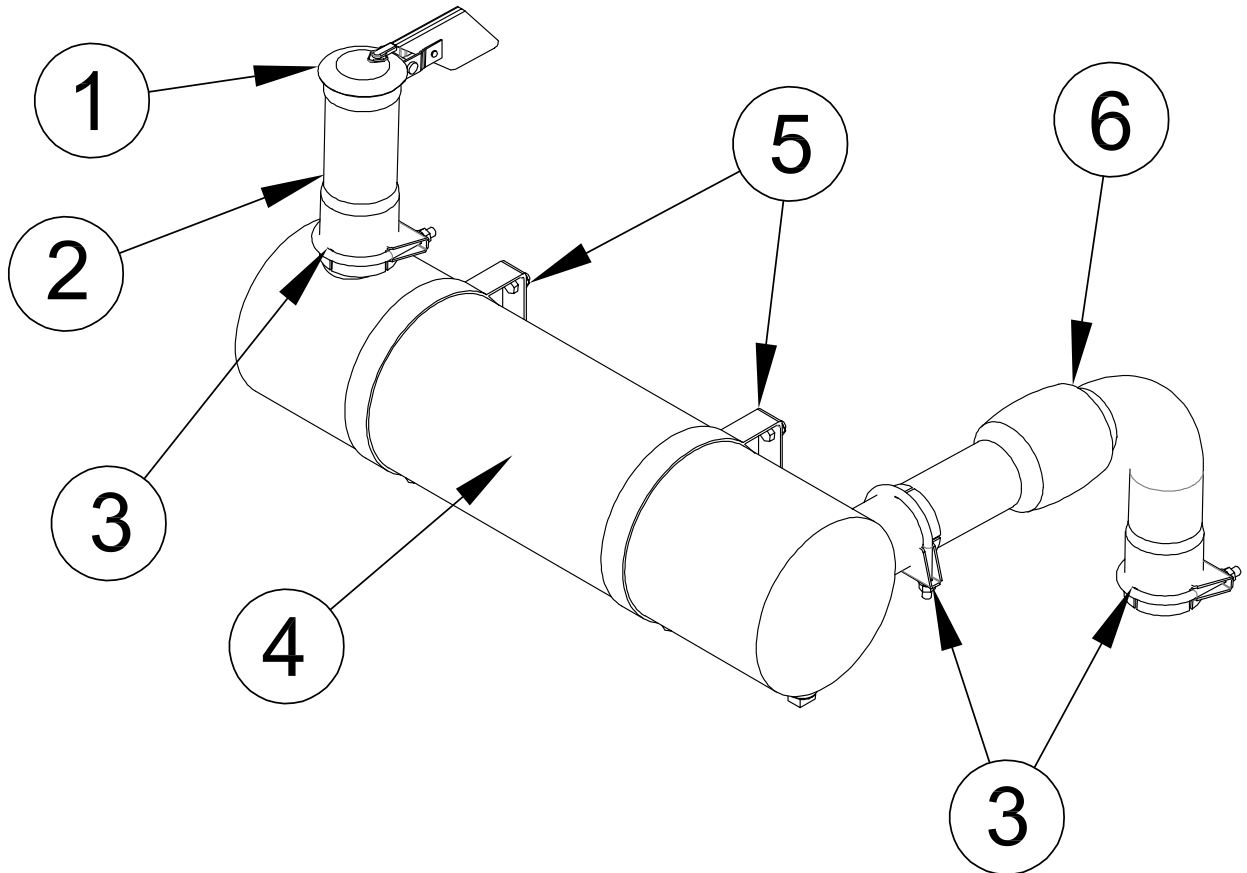

REF #	PART NUMBER	QTY	DESCRIPTION
1	53111-008	1	3" Rain Cap
2	99298-024	1	Exhaust Tail Pipe
3	93489-001	3	Muffer Clamp 3/8" X 3"
4	80519-011	1	Muffer
5	350264-7	2	Muffer Bracket
6	99502-011	1	Exhaust Flex

VAPOR FUEL SYSTEM ASSEMBLY

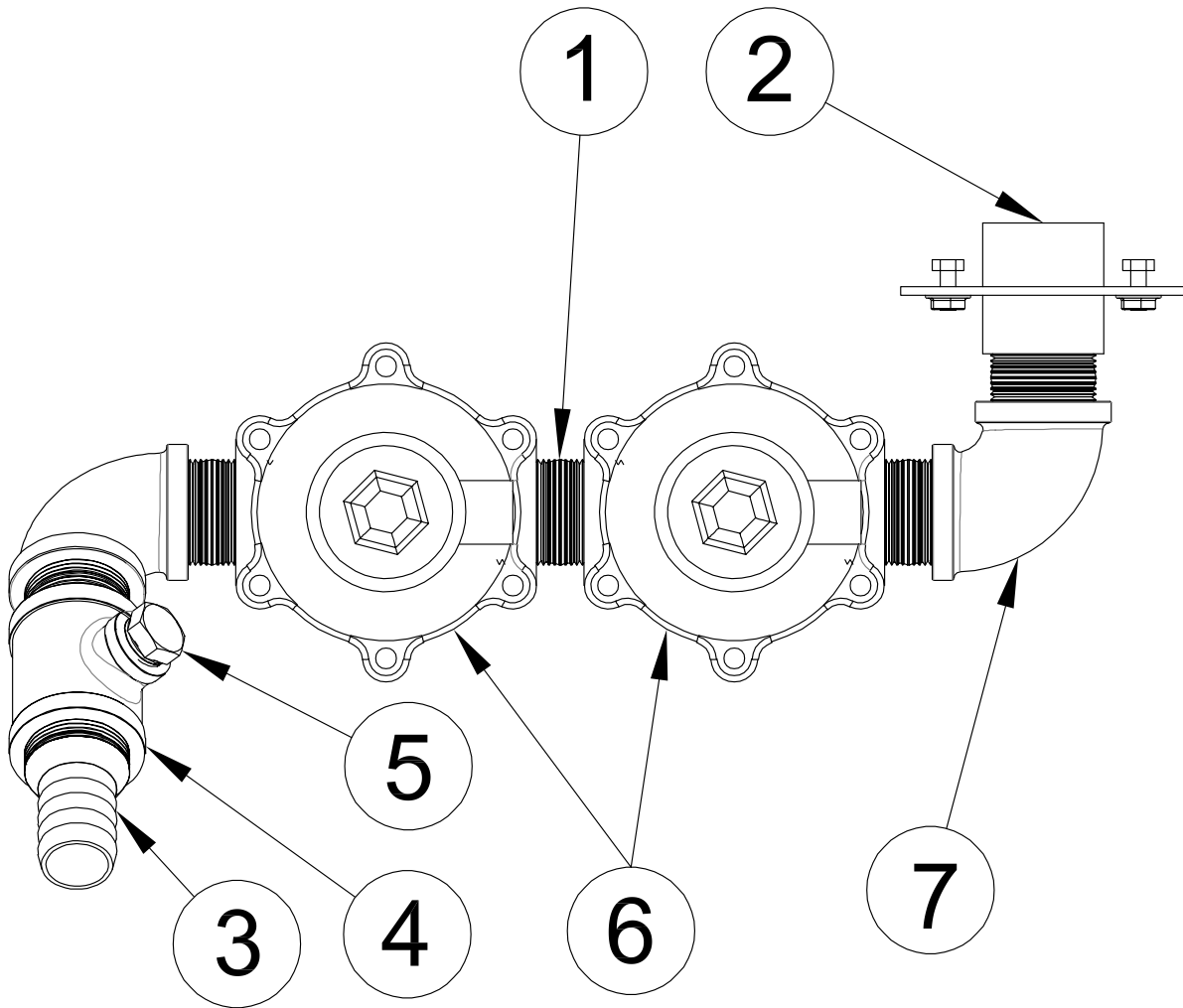

REF #	PART NUMBER	QTY	DESCRIPTION
1	22762-000	5	Pipe Nipple
2	99065-005	1	Fuel Inlet Weldment
3	92388-008	2	Hose Fitting
4	94906-001	1	Pipe Tee
5	97269-000	1	Pipe Plug
6	42942-125	2	Solenoid
7	92042-000	3	90° Pipe Elbow
NI	81018-004	2	Hose Clamp
NI	81103-000	1	1.25" I.D. Hose
NI	Not Illustrated		

GENERATOR MODIFICATION ASSEMBLY

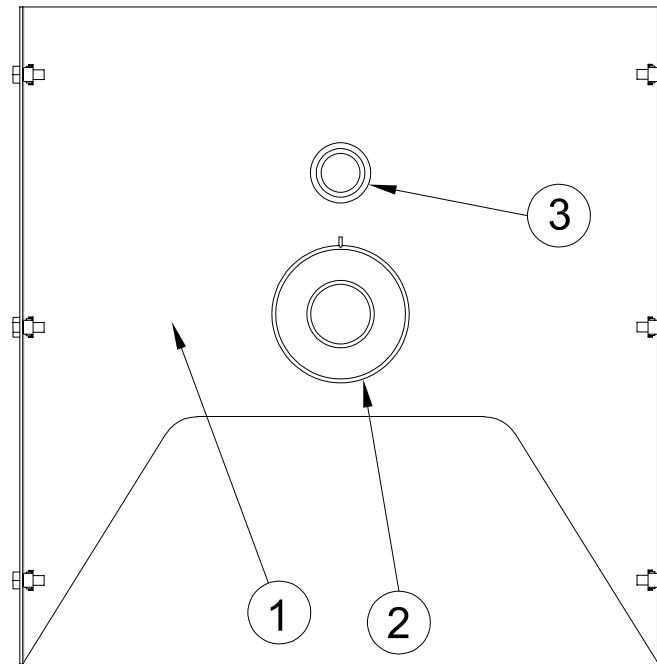

REF #	PART NUMBER	QTY	DESCRIPTION
1	64702-000	1	Front Panel
2	SEE TABLE	2 or 3	Current Transformer
3	62486-000	1	Grommet
NI	SEE TABLE	1	AC Harness

MODEL #	PART #	QTY	DESCRIPTION
ULPSS60-3/A	80124-008	2	500 to 5 Amp Current Transformer
ULPSS60-4/A ULPSS60-17/A ULPSS60-18/A	80124-008	3	500 to 5 Amp Current Transformer

MODEL #	PART #	QTY	DESCRIPTION
ULPSS60-3/A	99347-014	1	AC Harness
ULPSS60-4/A ULPSS60-17/A ULPSS60-18/A	99347-015	1	AC Harness

HOUSING ASSEMBLY

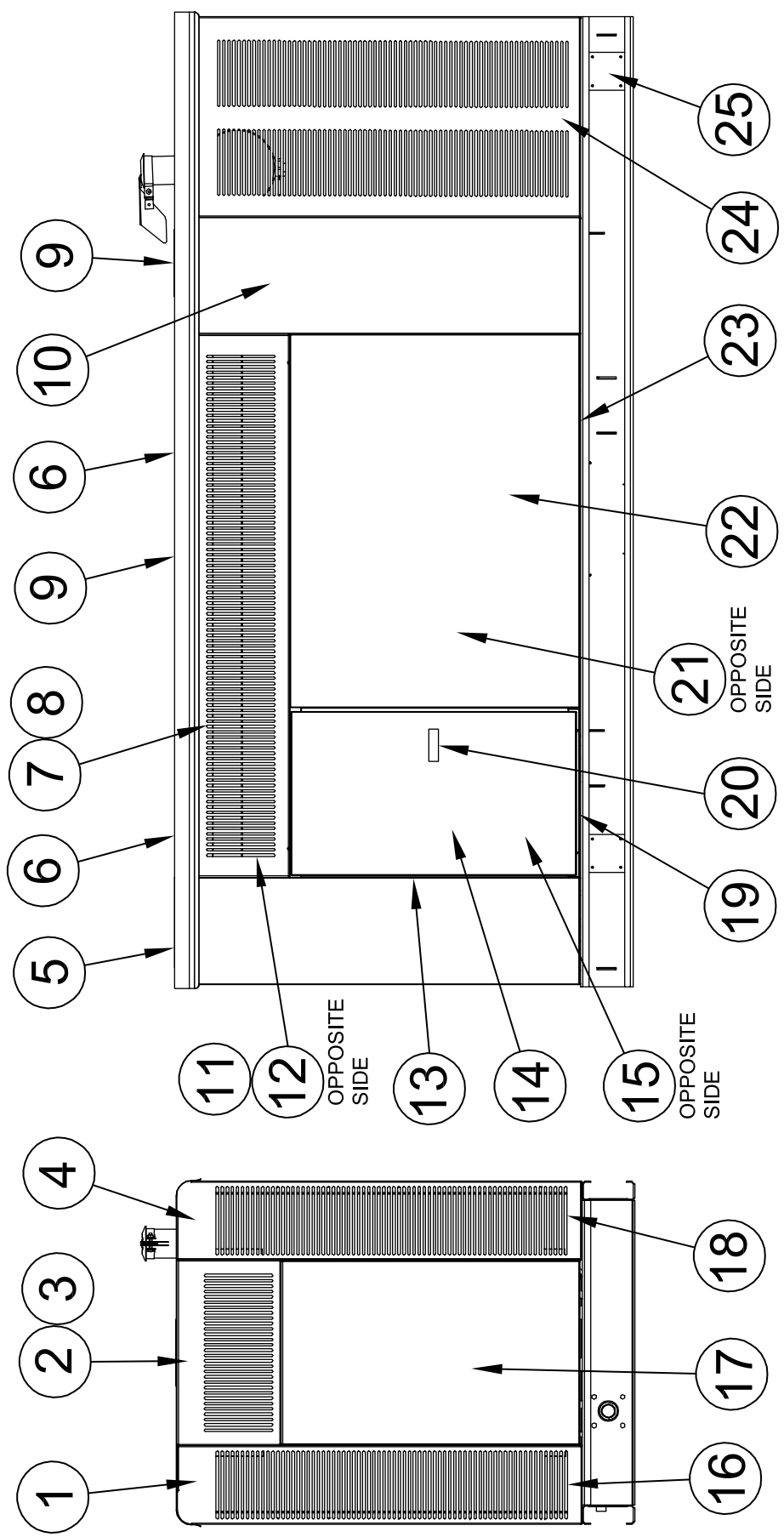

REF #	PART NUMBER	QTY	DESCRIPTION
1	99067-030	1	Left Rear Corner Panel
2	99100-062	1	Rear Sill
3	99378-054	1	Rear Sill Baffle
4	99067-029	1	Right Rear Corner Panel
5	99515-008	1	Roof
6	99225-003	2	Roof Support
7	99078-061	1	Right Side Sill
8	99378-056	1	Right Side Sill Baffle
9	99515-011	2	Roof Cover Plate
10	99071-034	1	Radiator Housing
11	99078-060	1	Left Side Sill
12	99378-055	1	Left Side Sill Baffle
13	98375-018	1	Hinge
14	15680-055	1	Right Side Door
15	99100-066	1	Left Side Rear Panel
16	99378-057	1	Left Rear Corner Baffle
17	99100-063	1	Rear Center Panel
18	99378-058	1	Right Rear Corner Baffle
19	99333-015	1	Door Stop
20	95229-005	1	Door Latch
21	99100-065	1	Left Side Panel
22	99100-064	1	Right Side Panel
23	65000-003	8	Thumb Screws
24	99071-028	1	Front Housing
25	99060-008	4	Lifting Hole Cover Plate

ACOUSTIC FOAM PIECES

REF #	PART NUMBER	QTY	DESCRIPTION
1	99393-406	2	Side Sill Foam
2	99393-409	1	Radiator Housing Foam
3	99393-405	2	Rear Baffle Foam
4	99393-403	1	Back Center Foam
5	99393-408	2	Front Side Foam
6	99393-407	2	Side Panel Foam
7	99393-401	1	Door Foam
8	99393-402	1	Rear Center Panel Foam
9	99393-404	1	Back Top Foam
10	99393-410	1	Roof Foam

ACOUSTIC FOAM PIECES

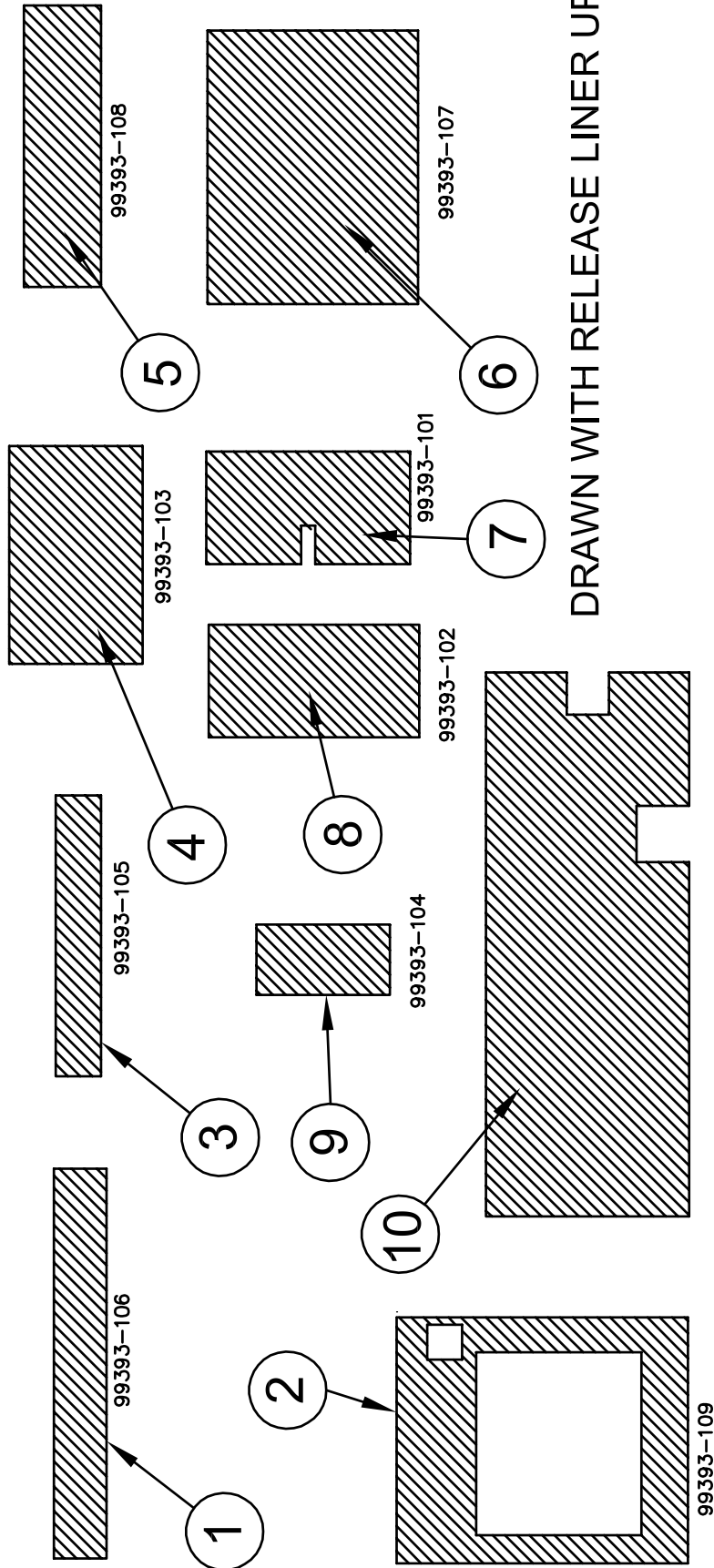

DRAWN WITH RELEASE LINER UP.

ULPSS60-4/A

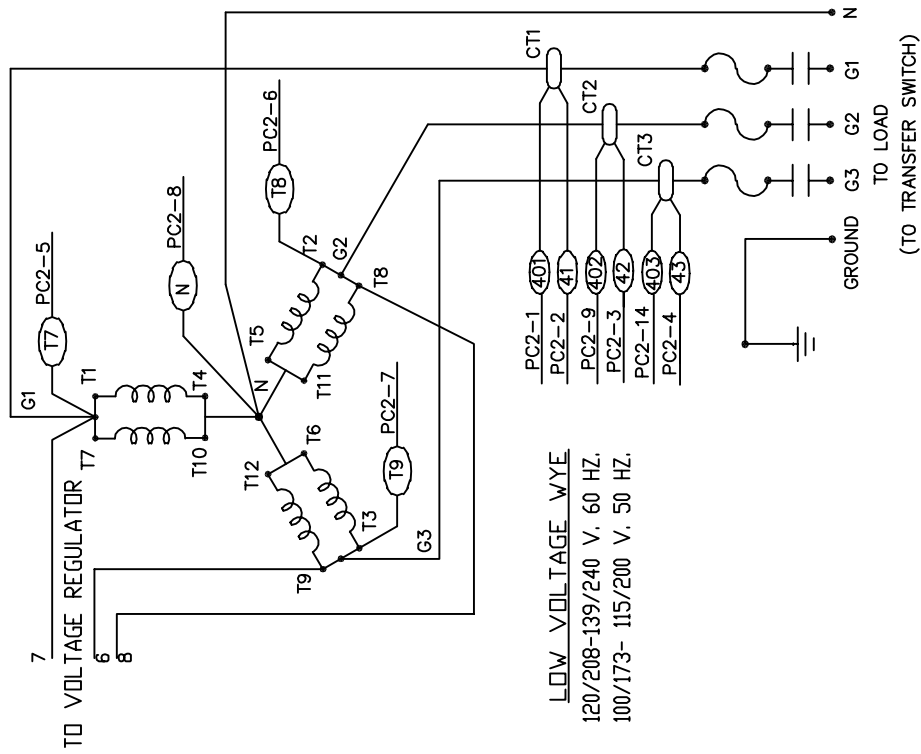

ULPSS60-17/A

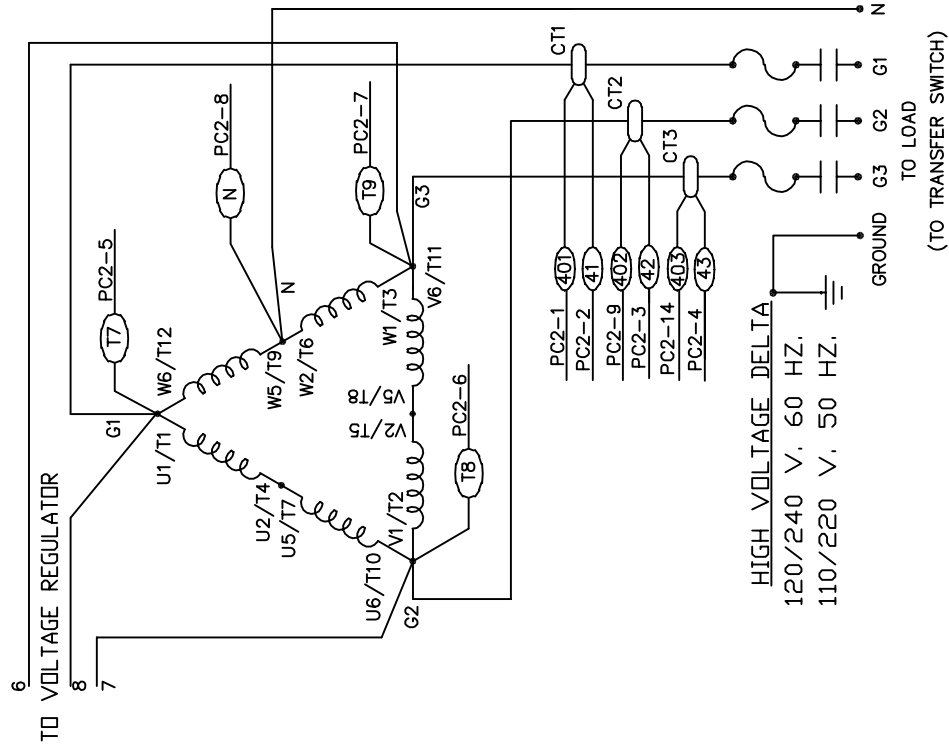

DC WIRING SCHEMATIC

