



WINPOWER CORPORATION

Model DR90H4-J Type II
 90 KW 112.5KVA .8 P.F. 60 HZ
 3 Phase 270.6Amps 4 Wire
 120/240 Volts 130°C Rise
 Wiring Diagram IF-5216-5
 Released: 1-11-77

<u>REF. NO.</u>	<u>PART NO.</u>	<u>PART DESCRIPTION</u>	<u>REQ'D/UNIT</u>
1	EC-17601	Engine Hercules D-4800T	
2	G-6408	Skid Assembly	2
	9268	Screw 5/8-11 x 1-1/2	2
	1189	Washer 5/8 Flat Steel	2
	4621	Nut 5/8-11 Hx	2
	1148	Washer 5/8 Lock	2
3	S-5814-1	Coupling Disc	2
	S-6896-1	Screw 3/8-16 x 3/4	7
	1185	Washer 3/8 Flat Steel	7
4	S-6878-3	Fan Spacer	4
	S-6896-4	Screw	4
5	G-6064	Fan Assembly	1
6	Not Applicable		
7	G-5824	Fan Guard	1
	3530	Screw 1/4-20 x 1-1/2	1
	5805	Nut 1/4-20	2
8	G-5737-23	Stator & Frame Assembly	1
9	G-5820-1	Frame Assembly	1
10	G-6887	Stator, Electrical	1
11	Not Applicable		
12	G-5506-1	Engine Adapter	1
13	G-6926	Revolving Electric Assembly	1
14	N-589	Shaft	1
15	G-5710	Heat Sink	1
16	EE-2123	Diode - Forward	1
17	EE-2122	Diode - Reverse	1
18	G-6913	Rotor Electric Assembly	1
19	G-5744	Exciter, Armature	1
20	I-825-2	Coupling Hub	1
	3887	Screw 1/2-13 x 1/2 Soc Hd	1
21	D-49	Bearing	1
22	G-5803	Exciter Frame Assembly	1
	S-6912	Exciter Frame	1
	3582	Screw 5/16-18 x 1-1/4 Hx Hd	12
	1116	Washer I.T.	12
	G-192-1	Field Pole Assembly	4
	J-587	Insulator	8
	H-1066	Field Coil Assembly	4
23	S-6797	Bearing Retainer	1
	S-6872	Bearing Spacer	1
	3522	Screw 1/4-20 x 1/2	2
	1114	Washer 1/4 I.T.	2
24	I-879	Bearing Housing	1
	3580-2	Screw 3/8-16 x 1-1/4 Gr 5	6
	1144	Washer, Split Lock	6
25	S-6945	Bracket	1
26			
27	EE-1201	Start Contactor	1
28	3547.01	Screw 5/16-18 x 1-1/4 Brass	2
29	J-592	Washer, Nylon	1
30	J-593	Washer 5/16 Nylon	1
31	Z-283	Nameplate, Positive Battery	1
32	Z-284	Nameplate, Negative Battery	1
	1034	Washer, Flat Brass	6
	4710	Nut 5/16-18 Brass	4
	1115	Washer 5/16-18 Brass	6
33	OP-23	Oil Pressure Switch 1/8 NPT	1
34	WT-22	Water Temperature Sender 1/4 NPT	1
35	OP-22	Oil Pressure Sender	1
36	WT-23	Water Temperature Switch 1/2 NPT	1
37	EN-18174	Tee 1/8M to 1/8F to 1/8F	1
38	EN-1802	Bushing 3/8M to 1/4F NPT	1
39			
40	OP-24	Oil Pressure Switch	1

PL-1812

OPTIONAL ON SOME MODELS

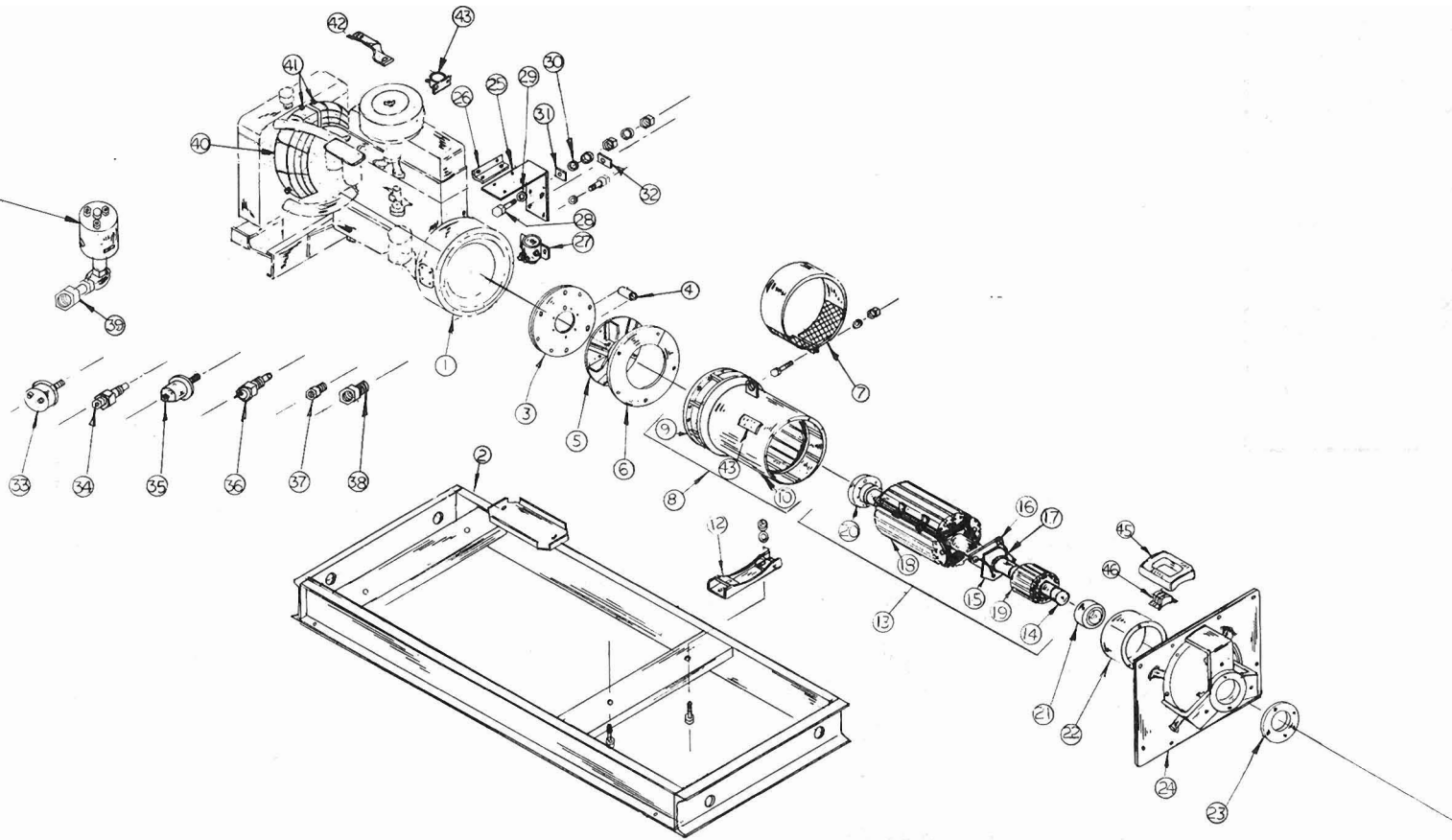

REF. NO.	PART NO.	PART DESCRIPTION	REQ'D/UNIT
1	G-6864	Panel Assy. Complete 20 in. Lam.	1
2	G-5739-3	Panel Cabinet Assembly	1
3	S-6854	Panel Side - Left	1
4	S-6856	Panel Side - Right	1
5	S-6857	Panel Bottom	1
	S-6853	Panel Top	1
	3522	Screw 1/4-20 x 1/2 H.H.	8
	1114	Washer 1/4 Int.	8
	5805	Nut 1/4-20 H.H.	8
6	G-5722-3	Terminal Board Assembly	1
7	J-578	Terminal Board	2
	3526	Screw 1/4-20 x 1 H.H.	4
	1114	Washer 1/4	4
	5805	Nut 1/4-20	4
8	S-6850	Bracket - Mounting	2
9	B-718	Link	10
	3670-1	Screw 1/2-13 x 2 Hex Brass	13
	1118	Washer 1/2 Int. T.T.	39
	1031	Washer 1/2 Flat Brass	39
	4716	Nut 1/2-13 Hex Brass	26
10	6100	Grommet	1
11	EE-646-1	Terminal Board 6-Pole	1
12	EE-646-2	Insulator	2
	2045	Screw #8-32	2
	5802	Nut #8-32	2
13	EE-653	Terminal Board 8-Pole	3
14	EE-653-8	Insulator	1
15	EE-653-2	Insulator	2
	2045	Screw #8-32	6
	5802	Nut #8-32	6
16	6221	Plug Button	1
17	EE-2214	Auto. Exciter Field Flasher	1
18	EE-471-2	Fuse 1 Amp.	1
	2005	Screw #6 x 1/2 lg.	2
	5801	Nut #6-32 H.H.	2
19	6905	Bushing	1
20	G-6865	Engine & Generator Sub. Assembly	1
21	S-6871	Panel Bottom	1
22	W-166-2	Shockmounts	4
23	EE-1750	Voltage Regulator	1
	2087	Screw 10-24 x 3/4 RHMS	4
	5803	Nut #10-24	8
24	EE-233	Push Button Switch	1
25	EE-181	Toggle Switch on-off-on	1
26	Z-1123	Nameplate - Adjust Volts	1
27	EE-1207-1	Socket - Relay	1
	2011	Screw #6-32 x 1-1/4 RHMS	2
	5801	Nut #6-32	2
28	EE-1207-2	Hold Down Clamp	1
29	EE-1220	Relay	1
	EE-1219	Socket	1
30	6100	Grommet	1
31	R-171	Resistor	1
32	EE-646-1	Terminal Block 6-Pole	2
33	EE-646-2	Insulator	2
34	EE-653	Terminal Block 8-Pole	2
35	EE-653-2	Insulator	1
36	EE-653-8	Insulator	1
	2045	Screw #8-32 x 1/2	6
	5802	Nut #8-32	6
37	G-5724	Front Panel Assembly	1
	2085	Screw #10-24 x 1/2 lg.	3
	5803	Nut #10-24	3
38	S-6870	Brace	1
	2085	Screw #10-24 x 1/2 lg.	2
	1019	Washer	2
39	EE-1811	Eng. Safety Circuit Breaker	1
	EE-1812-5	Circuit Breaker Heater	1
40	EE-1233	Relay-Latching	1
	EE-1233-1	Relay Socket	1
41	Z-1671	Nameplate-Engine Safety	1
42	EE-937-1	Failure Light	1
43	Z-2092	Nameplate Engine Shutdown	1
44	AM-12	Ammeter	1
45	OP-21	Oil Pressure Gauge	1
46	WT-21	Water Temperature	1
47	EE-151	Switch	3
48	Z-2093	Nameplate Stop Run	1
49	Z-920-1	Nameplate Off-On	1
50	EE-425	Fuse Holder	1
51	EE-445-2	Fuse Amp	1
52	Z-2116	Nameplate - Regulator	1
53	EE-924-1	Panel Lamp Holder	2
	EE-940-1	Lamp 12 Volt	2
54	G-5723	Panel Top Assembly	1
	2085	Screw #10-24 x 1/2	3
	5803	Nut #10-24	3
55	4957	Tinnerman	7
	2325	Screw 1/4-20 x 1/2 Truss Head	7
56	G-5819	Diode Assembly Blocking	1
	J-546	Shoulder Washer - Nylon	2
	J-583	Washer - Flat - Nylon	2
	2087	Screw #10-24 x 3/4	2
	5803	Nut #10-24	2
57	G-5183-3	Diode Assembly Blocking	1
58	4956	Tinnerman	1
	6224	Plug Button 23/32 Dia.	3
	6223	Plug Button 1" Dia.	3
	6218	Plug Button 1/2" Dia.	2
59	G-5724	Panel Front Assembly	1
	4957	Tinnerman	6
	3522	Screw 1/4-20 H.H.	6
	1183	Washer 1/4 Flat. Stl.	6
60	EE-1203	Relay	1
61	EE-1054	Time Delay Relay	1
62	G-6533-1	Voltmeter & Sel. Switch Assy.	1
63	VM-69-1	Voltmeter 0-300 Volt	1
64	EE-275-1	Selector Switch	1
65	S-6822-1	Meter Panel	1
66	S-6832	Basic Panel	3

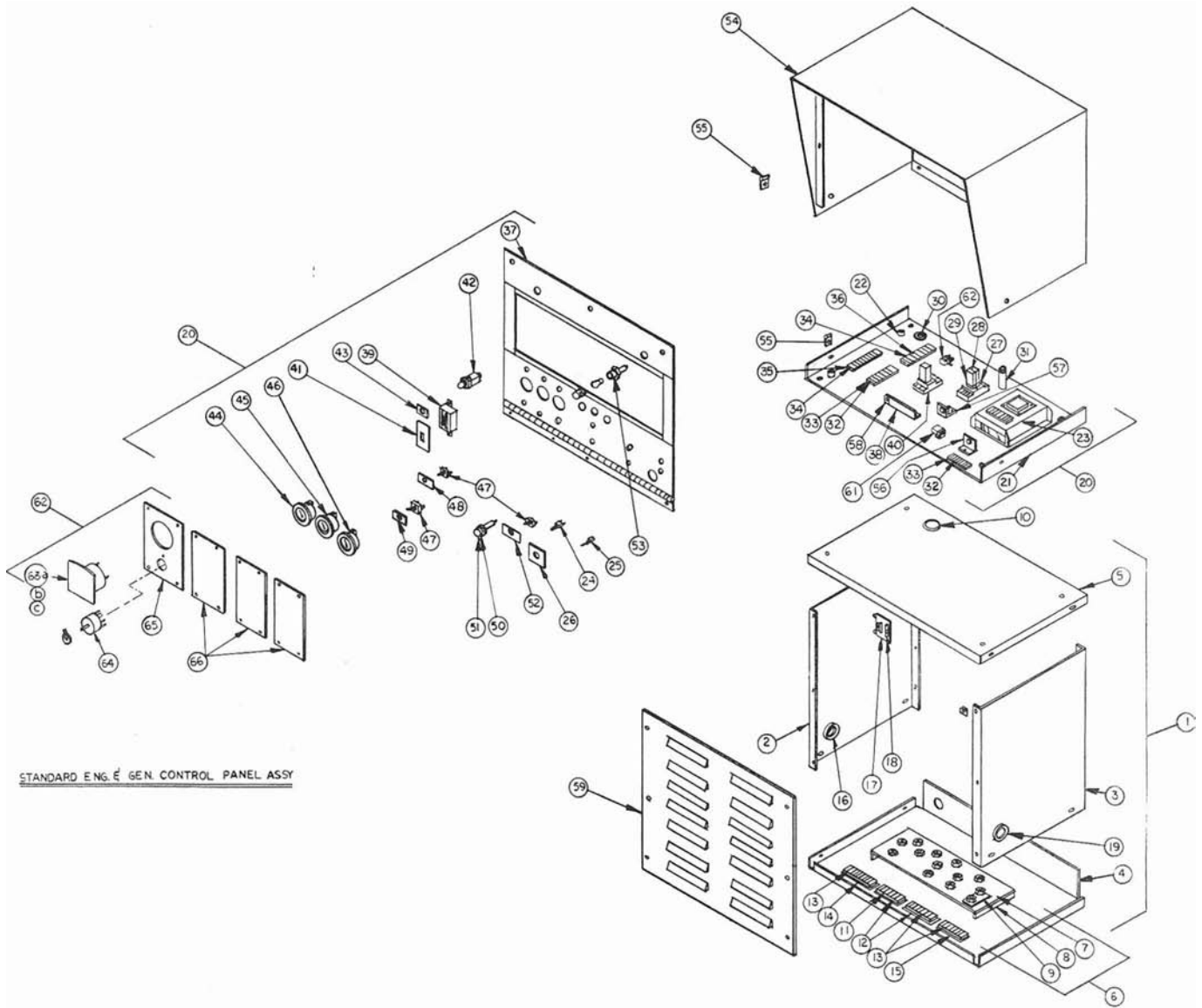

IF-5188

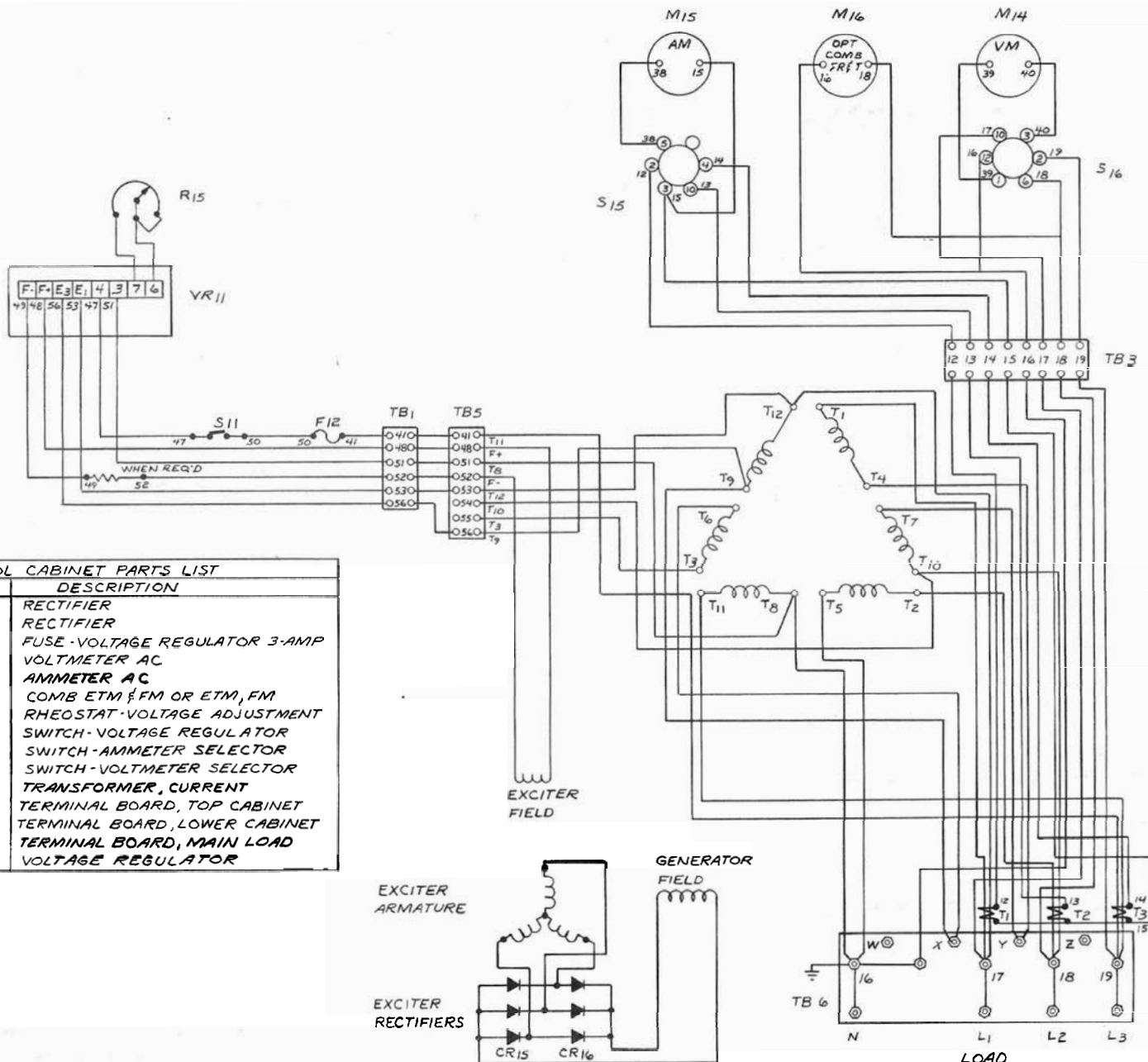

CONTROL CABINET PARTS LIST		
RFF	PART NO	DESCRIPTION
CR15	EE-2122	RECTIFIER
CR16	EE-2123	RECTIFIER
	EE-445-2	FUSE-VOLTAGE REGULATOR 3-AMP
M14	VM-35	VOLTMETER AC
M15	_____	AMMETER AC
M16	_____	COMB ETM & FM OR ETM, FM
R15	R-91	RHEOSTAT-VOLTAGE ADJUSTMENT
S11	EE-151	SWITCH-VOLTAGE REGULATOR
S15	EE-276-1	SWITCH-AMMETER SELECTOR
S16	EE-275-1	SWITCH-VOLTMETER SELECTOR
T1,2,3	_____	TRANSFORMER, CURRENT
TB1,3	_____	TERMINAL BOARD, TOP CABINET
TE5	_____	TERMINAL BOARD, LOWER CABINET
TB6	_____	TERMINAL BOARD, MAIN LOAD
VR11	EE-175C	VOLTAGE REGULATOR

CRANE	WAS ORIGINALLY	DATE	CHK'D	CHK REQUEST	NO. REC'D	MICROFILM DATA

TOLERANCE ON DIMENSIONS NOT OTHERWISE SPECIFIED

DECIMAL ±	FRACTIONAL ±	ANGULAR ±	REMOVE ALL BURRS	BREAK ALL SHARP MACHINED EDGES
-----------	--------------	-----------	------------------	--------------------------------

MATERIAL _____

120/240 TO 133/277 VOLTS, 60 HZ
 115/230 TO 133/266 VOLTS, 50 HZ

SCHEMATIC DIAGRAM
 GENERATOR REGULATOR
 INSTRUMENTATION

SCALE _____ MODEL NO _____
 DATE 2-4-77 PART NO. 1F-5216-5
 BY KH

WINPOWER CORPORATION
 NEWTON, IOWA 50206

ENGINE PARTS LIST		
REF.	PART NO.	DESCRIPTION
B1	SEE ENG. MAN.	START MOTOR W/ SOLENOID SWITCH
BT1	VARIOUS	BATTERY
C1	SEE ENG. MAN.	CAPACITOR (SPARK IGNITED ENGINES ONLY)
E1	OP-22	SENDER - OIL PRESSURE
E2	WT-22	SENDER - WATER TEMP.
E3	SEE ENG. MAN.	SPARK PLUG (SPARK IGNITED ENGINES)
G1	SEE NOTE #2	ALTERNATOR OR GENERATOR (BATT. CHARGE)
K1	EE-1201	RELAY - STARTER MOTOR
K2	SEE ENG. MAN.	SOLENOID - FUEL
K3	SEE ENG. MAN.	CHOKE (GASOLINE ONLY)
R1	SEE ENG. MAN.	RESISTOR COIL (OPTIONAL-SPARK IGNITED ENG. ONLY)
R2	SEE ENG. MAN.	RESISTORS - SPARK PLUGS
S1	OP-23	SWITCH - LOW OIL PRESSURE (CLOSED 0-15 PSI)
S2	WT-23	SWITCH - HIGH WATER TEMPERATURE
S3	OP-24	SWITCH - STARTER MOTOR SAFETY (CLOSED 0-35 PSI)
S4	VARIOUS	SWITCH - OVERSPEED (OPTIONAL)
S6	SEE ENG. MAN.	DISTRIBUTOR ASSY. (SPARK IGNITED ENG. ONLY)
S8	SEE ENG. MAN.	SWITCH - VACUUM (GASEOUS FUELS ONLY)
T1	SEE ENG. MAN.	COIL IGNITION (SPARK IGNITED ENG. ONLY)
VR1	SEE ENG. MAN.	VOLTAGE REGULATOR - BATTERY CHARGING

CONTROL CABINET PARTS LIST		
REF.	PART NO.	DESCRIPTION
CB11	EE-1811	CIRCUIT BREAKER - SAFETY SHUTDOWN
CR12	G-5813-3	RECTIFIER - BLOCKING
CR13	G-5819	RECTIFIER - BLOCKING
CR14	EE-2171-4 or EE-2189	RECTIFIER - FIELD FLASHER
CR20	G-5819	RECTIFIER - BLOCKING
CR21	EE-2167	RECTIFIER - BLOCKING
DS11,12	EE-940	LAMP - PANEL
DS13	EE-940	LAMP - FAILURE
F11	EE-445-2	FUSE - FIELD FLASHER
K11	EE-1220	RELAY - CRANKING CONTROL
K18	EE-1233	LATCHING RELAY
K14	EE-1203	RELAY
K20	EE-1054	TIME DELAY RELAY
M11	OP-21	GAUGE - OIL PRESSURE
M12	WT-21	GAUGE - WATER TEMPERATURE
M19	AM-12	GAUGE - AMMETER - CHARGE 30-0-30 or 100-0-100
R11	R-171	RESISTOR - 33 OHM, 10 WATT
R16	R-157	RESISTOR - 100 OHM, 10 WATT
R20		RESISTOR - 125 OHM, 10 WATT
S12	EE-181	SWITCH - ENGINE - RUN, STOP, REMOTE
S13	EE-151	SWITCH - PANEL LAMP
S14	EE-233	DE-ENERGIZATION SWITCH - SAFETY SHUTDOWN

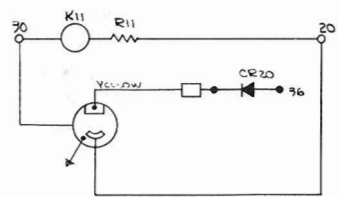
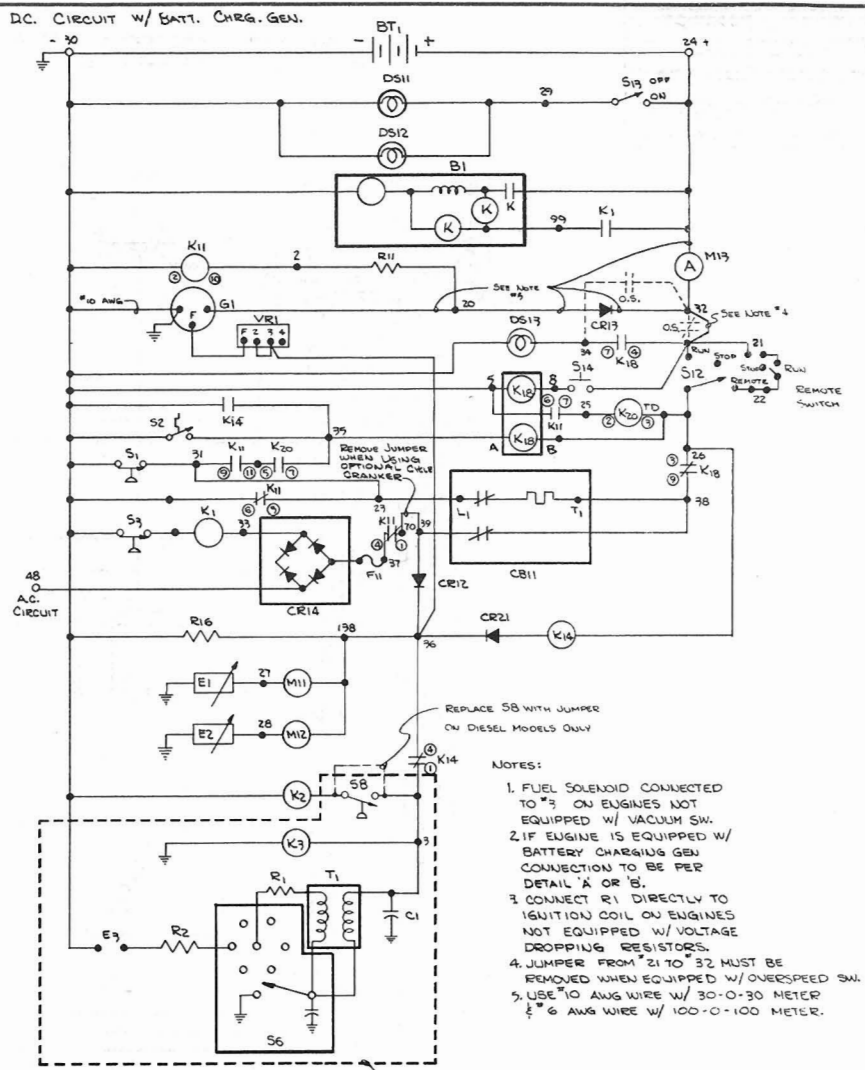

NOTE: ADD CR20 RECTIFIER

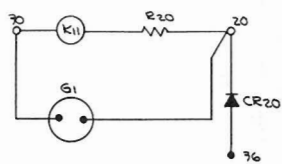

NOTE - ADD RECTIFIER CR20 REMOVE R11 & REPLACE W/ R20

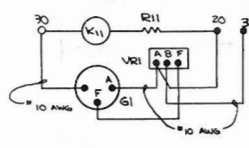

NOTE: REMOVE CR13 & LEADS FROM 20 TO 21 NO CONNECTION FROM #36 TO VR1

CHARGE	WAS ORIGINALLY	DATE	CHK'D	CHG. REQUEST	NO. REQ'D	MICROFILM DATA
TOLERANCE ON DIMENSIONS NOT OTHERWISE SPECIFIED						
DECIMAL ±		FRACTIONAL ±		ANGULAR ±		REMOVE ALL BURRS BREAK ALL SHARP MACHINED EDGES
MATERIAL						

12 VOLT ENGINE ELEC. CIRCUIT	
SCHEMATIC DIAGRAM	
SCALE: NONE	MODEL NO.
DATE: 10/5/76	PART NO.
DRW: SWF	CHK'D: Reddy
WINPOWER CORPORATION	
NEWTON, IOWA 50208	