

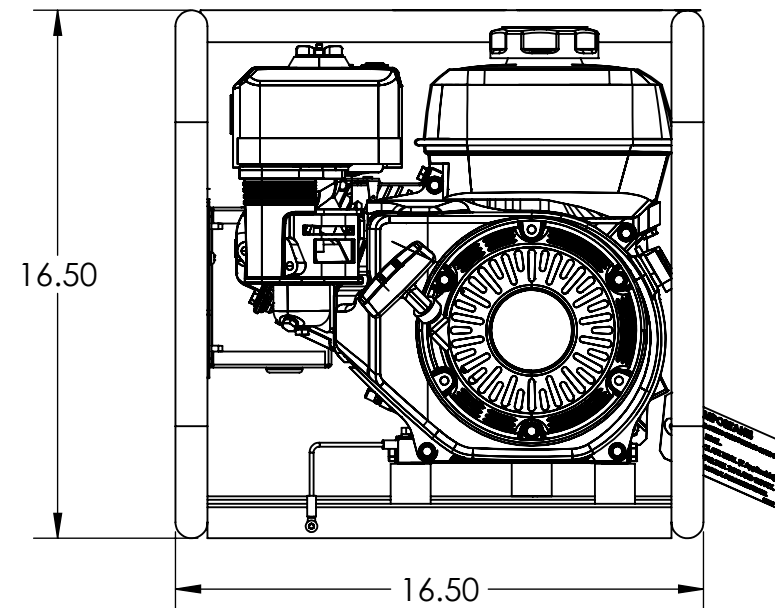

000-29006Z

REVISIONS					
REV.	IRN	DESCRIPTION	DATE	BY	APP'D
D	7269	REPLACED 100047-724 WITH -778, ADDED (1) 468-000 & (2) 480-000, & REMOVED (1) 580-000	6/5/2017	SJM	DRC

ITEM NO.	PartNo	DESCRIPTION	QTY.
1	100047-778	23.5 X 17 X 17 CARTON	1
2	15209-001	GASOLINE DECAL	1
3	15209-002	DECAL-DANGER CARBON MONOXIDE	1
4	15209-003	UL-DECAL ELECTRICAL SHOCK CAN KILL	1
5	15209-013	DECAL - FUEL TYPE GASOLINE	1
6	15209-014	DECAL - CHECK OIL	1
7	15209-101	DECAL, GASOLINE DANGER, FRENCH	1
8	15209-102	DECAL-DANGER CARBON MONOXIDE	1
9	15209-103	UL-DECAL ELECTRICAL SHOCK CAN KILL	1
10	15250-000	ENGINE HONDA GX160	1
11	15458-071	RECEPTACLE PANEL DP3000	1
12	16249-000	.3125-18 FLANGE NUT	3
13	16346-017	GENERATOR	1
14	21698-001	TORX PAN HEAD SCREW #10	4
15	300515-2	OIL	.63 QTS
16	468-000	.3125-18X1.5 HHCS	2
17	480-000	5/16 SPLIT LOCKWASHER	6
18	526-000	5/16 FLAT WASHER	2
19	580-000	5/16-18X1.25	1
20	60710-097	TAG OIL WARNING	1
21	63073-059	WELDED CRADLE ASSY	1
22	63941-001	DECAL -HOT SURFACES	1
23	63966-004	NAMEPLATE, WINCO PORTABLE	1
24	64062-000	SHOCKMOUNT, BLACK 40 DURO	3
25	64918-000	DECAL-DANGER (CO) USE OUTSIDE	1
26	82539-001	SELF TAP.SC.6X3/8	1
27	91547-000	.3125-24 X 1.000 HHCS	4
28	96286-002	FLAT WASHER NYLON	3
29	9769-145	LEAD WIRE ASSEMBLY	1
30	OPM-116	OPERATORS MANUAL	1

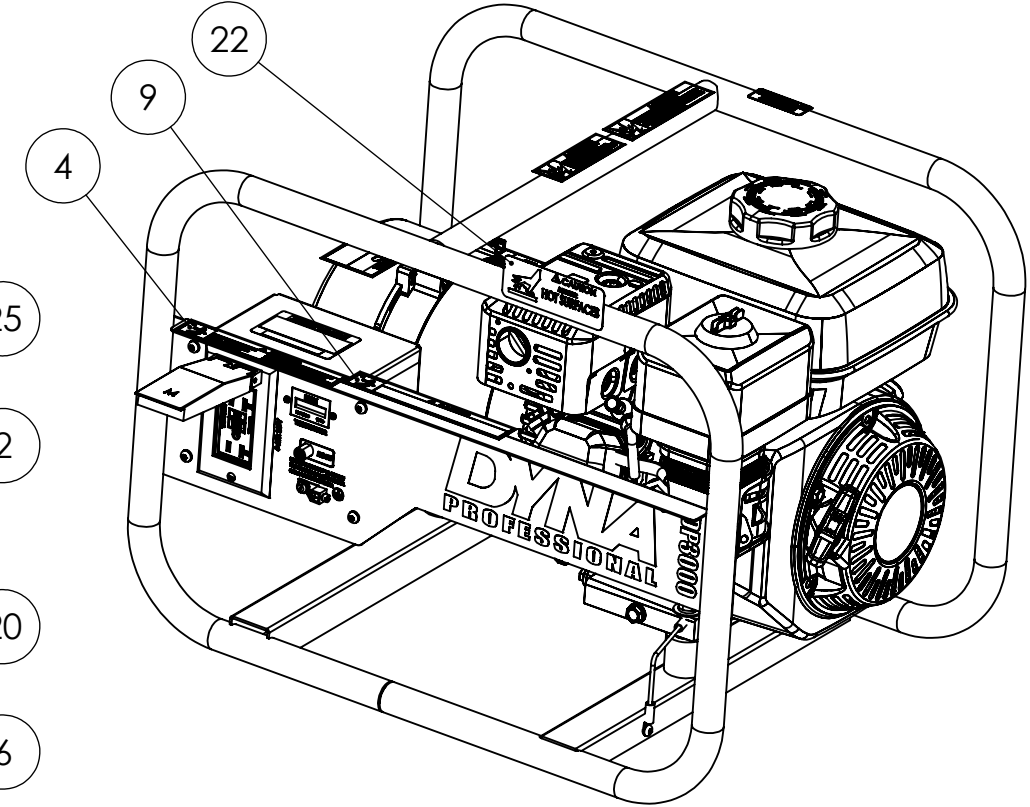
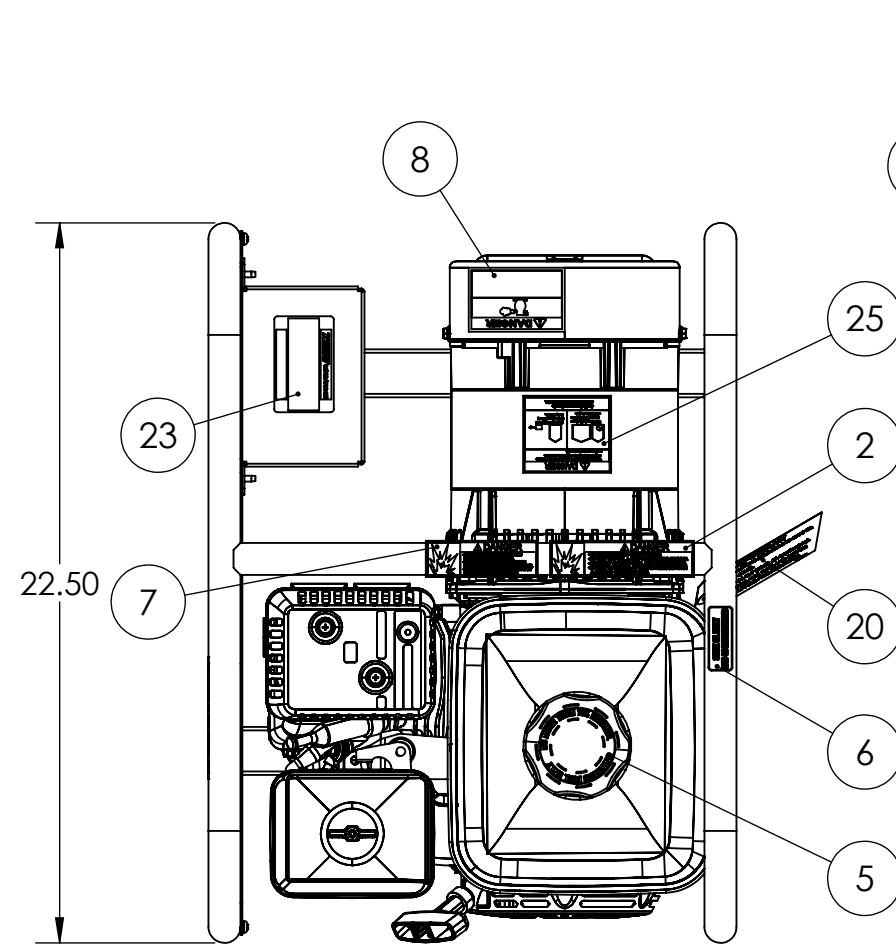
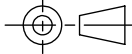



 THIS DRAWING CONTAINS PROPRIETARY INFORMATION BELONGING TO WINCO. UNAUTHORIZED USE IS PROHIBITED. ALL DIMENSIONS INCH	DRAWN BY SEW	DATE 12/14/2016	CHK'D BY	DATE	ENG APPR. DRC	DATE 2/22/2017
	TOLERANCE:	+/- 0.0625 DECIMAL +/- 1 DEG ANGULAR		TITLE: DP3000		
	MODEL:	DP3000		PART: 29003-000		
					1 of 2	

000-3006Z

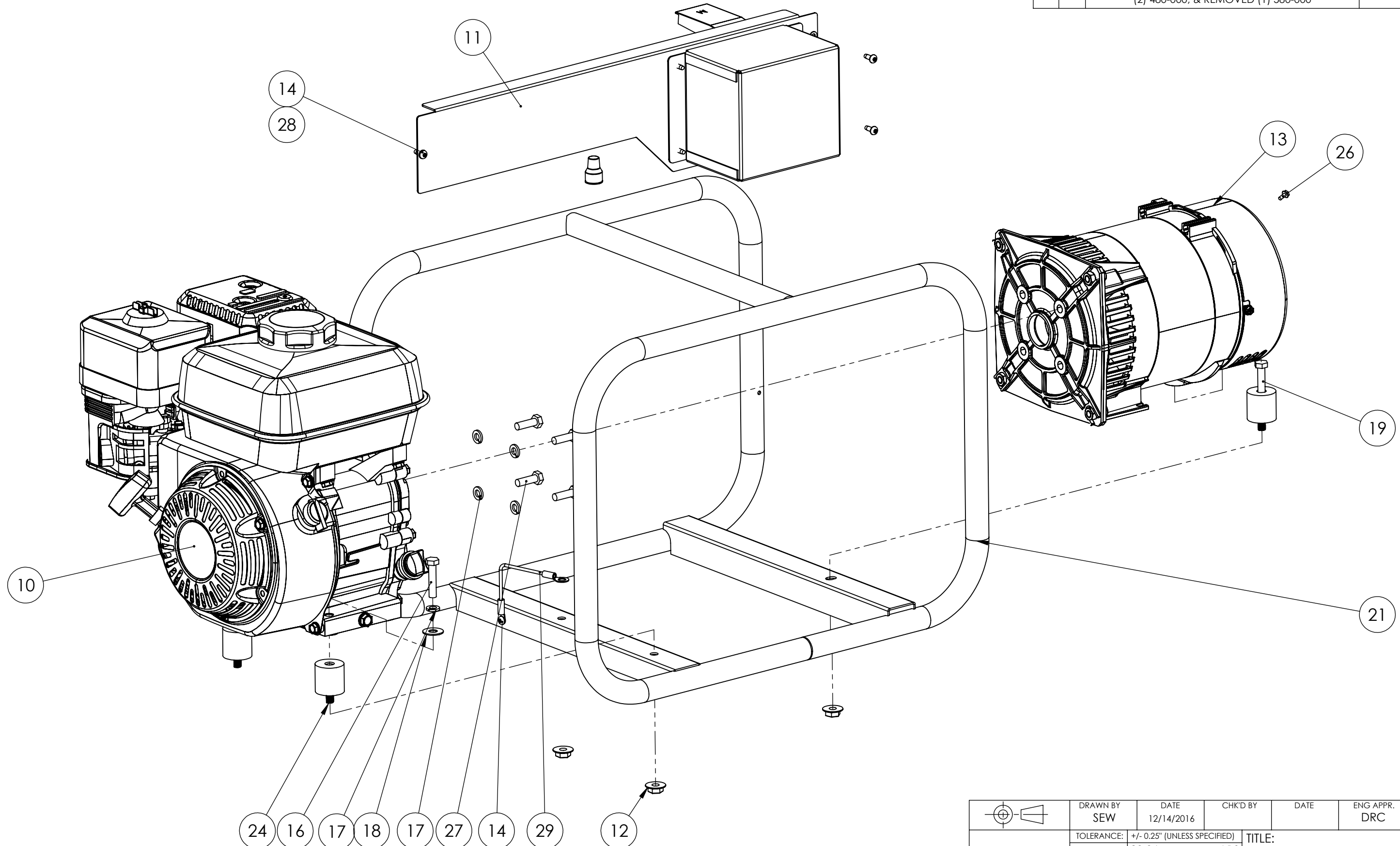
REVISIONS					
REV.	IRN	DESCRIPTION	DATE	BY	APP'D
D	7269	REPLACED 100047-724 WITH -778, ADDED (1) 468-000 & (2) 480-000, & REMOVED (1) 580-000	6/5/2017	SJM	DRC

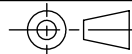

**NOTES:**  
 1. THROUGH BOLT TORQUE: 14 FT LBS  
 2. COUPLING TORQUE: 15.5 FT LBS

 THIS DRAWING CONTAINS PROPRIETARY INFORMATION BELONGING TO WINCO. UNAUTHORIZED USE IS PROHIBITED	DRAWN BY SEW	DATE 12/14/2016	CHK'D BY	DATE	ENG APPR. DRC	DATE 2/22/2017
	TOLERANCE:	+/- 0.25" (UNLESS SPECIFIED)		TITLE:		
	WEIGHT:	20.96	LBS	DP3000		
	MATERIAL:	SEE TABLE		PART: 29003-000		
MODEL:	DP3000					2 of 2