

£00-9Z09 I

* 15209-000 DECAL SET
 ** 15209-100 DECAL SET

ITEM NO.	PartNo	DESCRIPTION	QTY.
1	100047-603	31.875 X 24.25 X 24 CARTON	1
2	100054-650	BAG 52 X 24 X 45 1.0 MIL	1
3	100114-719	W15 W25 25PTO SKID	1
4	15209-002 *	DECAL-DANGER CARBON MONOXIDE	1
5	15209-003 *	UL-DECAL ELECTRICAL SHOCK CAN KILL	1
6	15209-036	PROP 65 WARNING DECAL	1
7	15209-102 **	DECAL-DANGER CARBON MONOXIDE	1
8	15209-103 **	UL-DECAL ELECTRICAL SHOCK CAN KILL	1
9	15457-082	RECEPTACLE PANEL ASSEMBLY	1
10	15869-006	FUEL PUMP SYSTEM	1
11	18000-044	ENGINE & GENERATOR COUPLING	1
12	18000-045	BASE ASSEMBLY	1
13	300515-2	OIL, 10W-30	1.3 QTS.
14	60710-018	OIL WARNING TAG	1
15	63966-004	NAMEPLATE, WINCO PORTABLE	1
16	64918-000	DECAL-DANGER (CO) USE OUTSIDE	1
17	97381-001	DECAL-DIESEL FUEL ONLY	1
18	97382-000	DECAL-DO NOT USE STARTING FLUIDS	1
19	OPM-125	OPR.MANUAL EC6010	1

REVISIONS					
REV.	IRN	DESCRIPTION	DATE	BY	APP'D
D	9350	ADDED 15209-036	12/11/2018	SJM	DRD

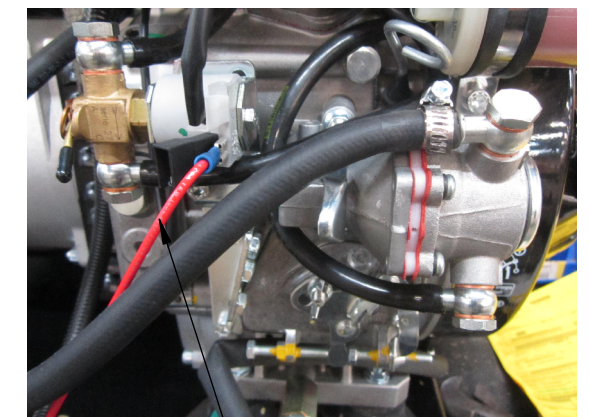
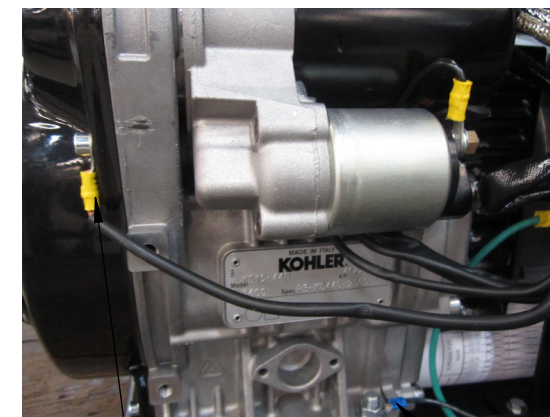
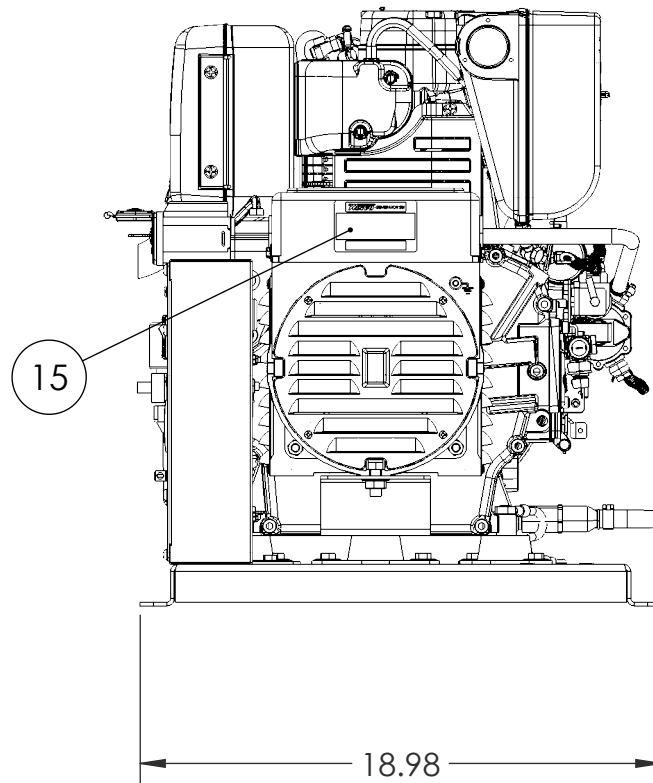
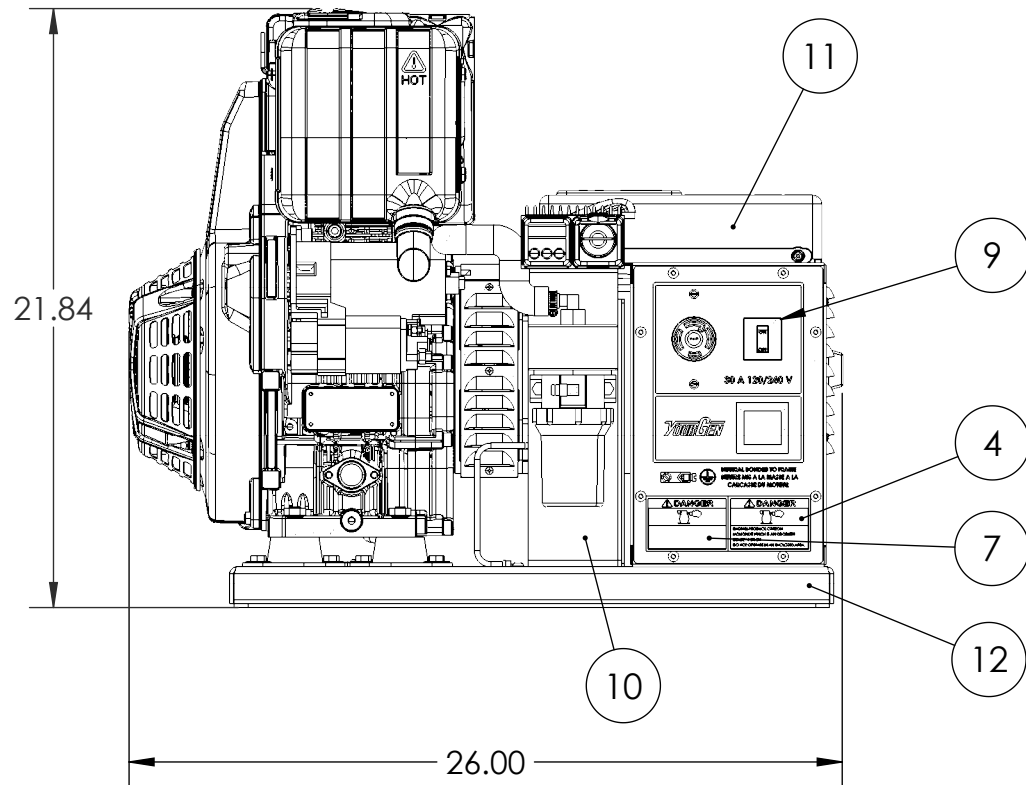
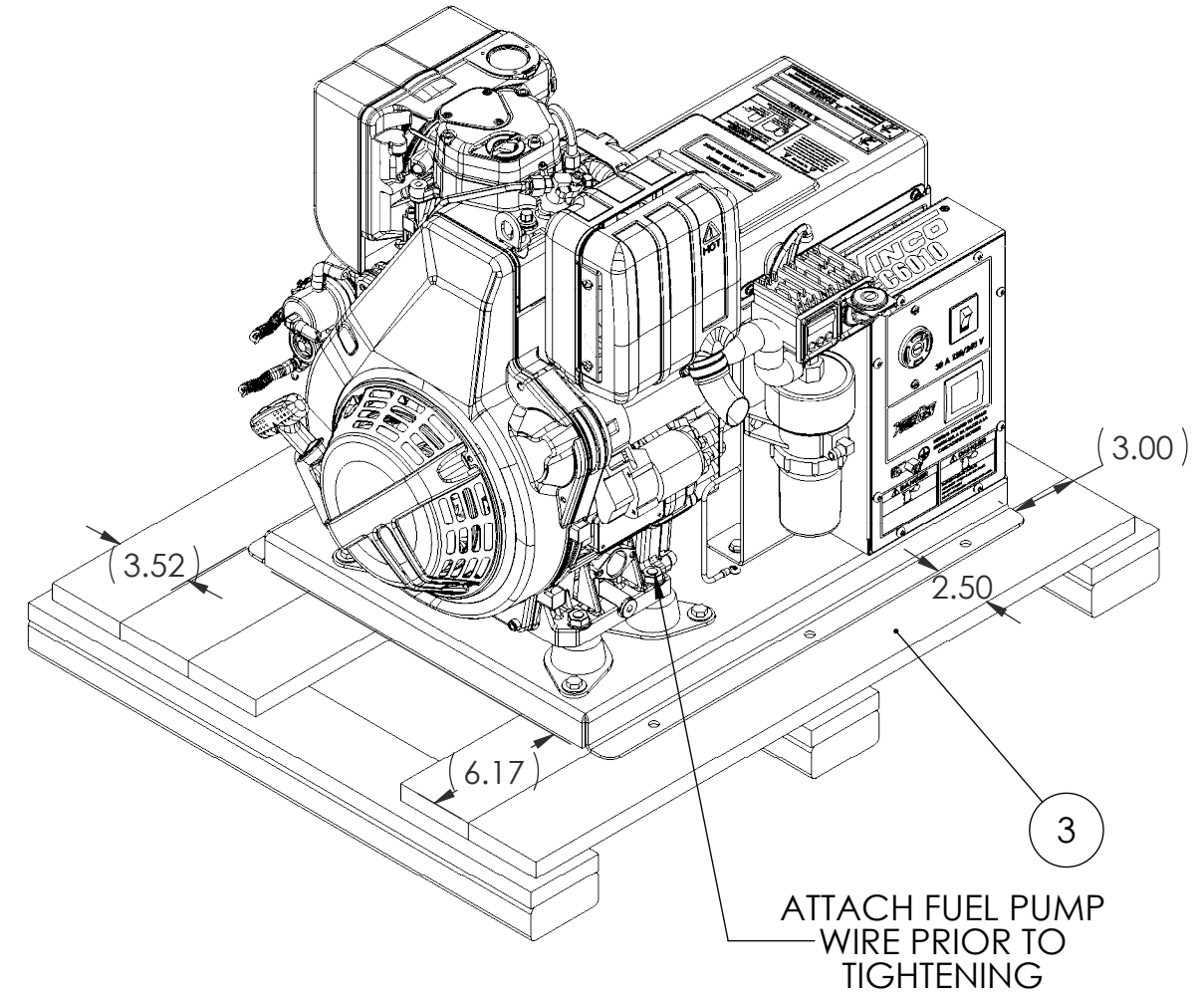
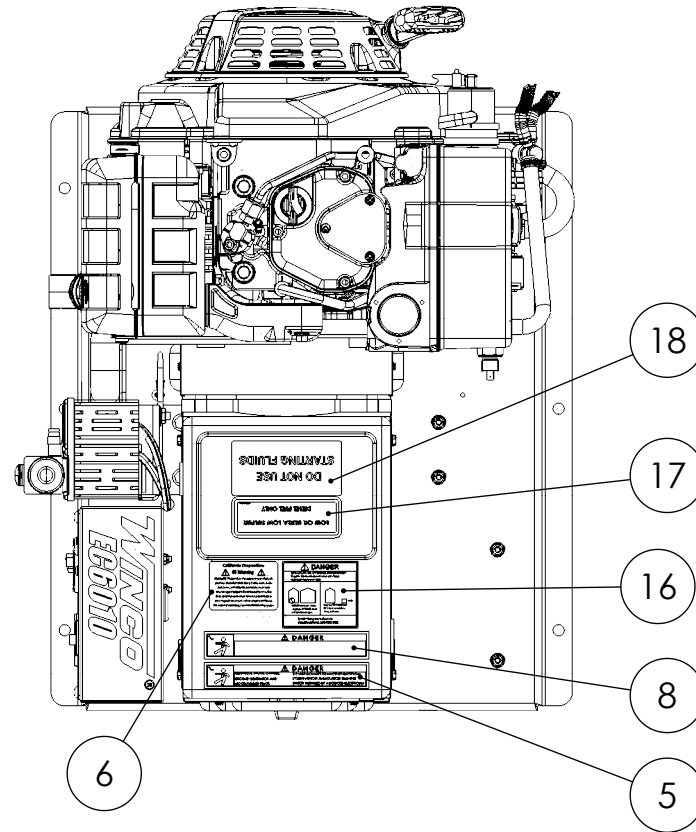

KEY START WIRE

FUEL PUMP
BLACK WIRE

FUEL PUMP
RED WIRE

 THIS DRAWING CONTAINS PROPRIETARY INFORMATION BELONGING TO WINCO. UNAUTHORIZED USE IS PROHIBITED. ALL DIMENSIONS INCH	DRAWN BY	DATE	CHK'D BY	DATE	ENG APPR.	DATE
	SJM	4/13/2018			DRD	6/14/18
	TOLERANCE:	+/- 0.0625 DECIMAL		TITLE: EC6010 COMPLETE ASSEMBLY		
	MODEL:	EC6010DR/T		PART: 16076-003 1 of 1		

