

O-584

REVISIONS					
REV.	IRN	DESCRIPTION	DATE	BY	APP'D
A	CASE12831	NEW PART	5/31/2024	VP	DRC

Key Components

A	ENGINE CONTROL
B	MAIN LINE CIRCUIT BREAKER
C	START BATTERY
D	OIL FILL
E	OIL DRAIN
F	OIL DIPSTICK
G	OIL FILTER
H	FUEL FILTER
I	FUEL IN
J	FUEL RETURN
K	AIR FILTER
L	COOLANT DRAIN
M	COOLANT FILL

MOUNTING HOLE PATTERN

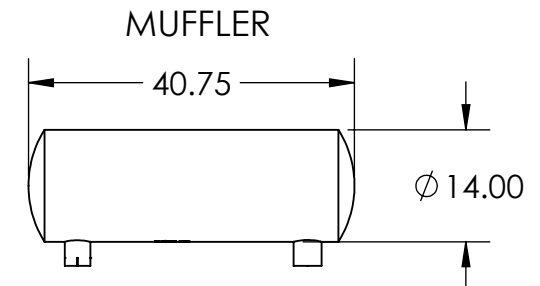
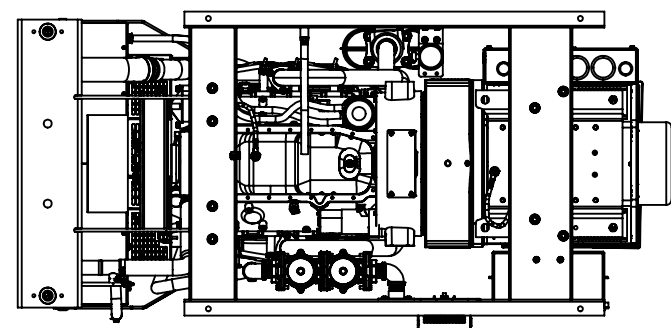
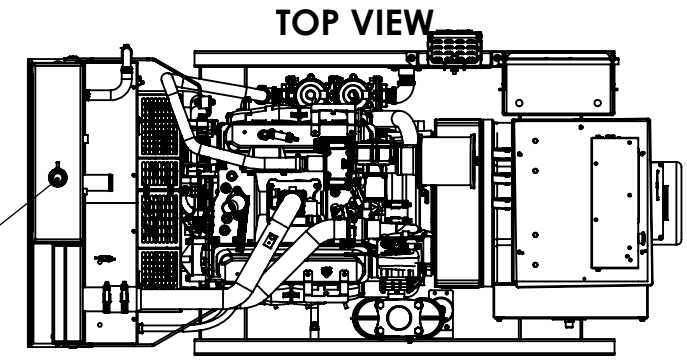
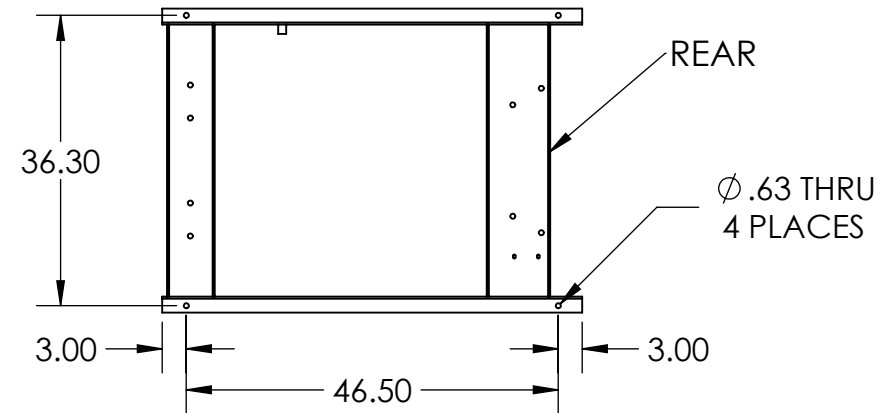

BOTTOM VIEW

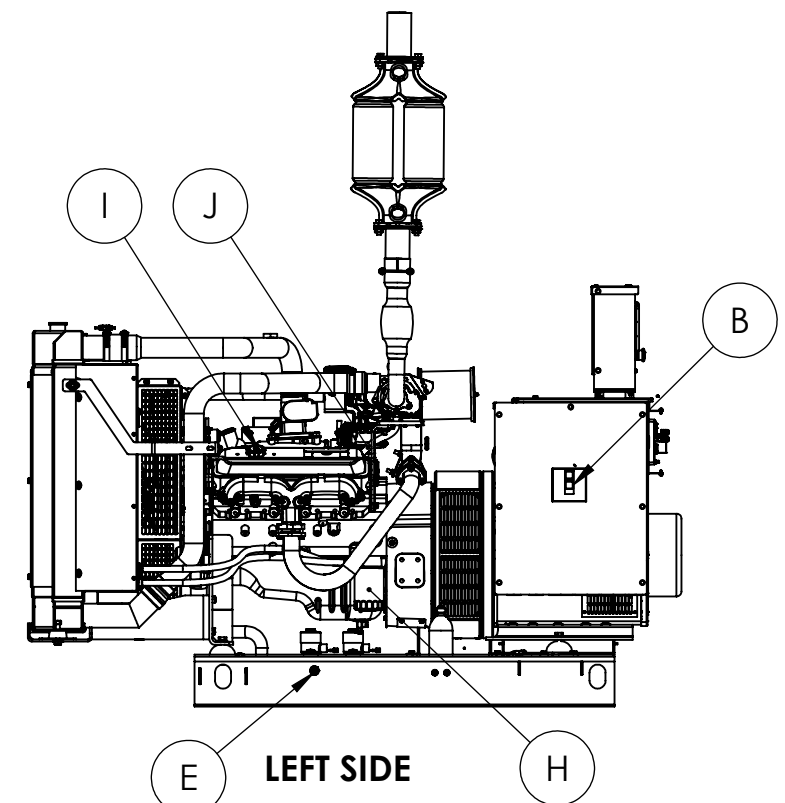
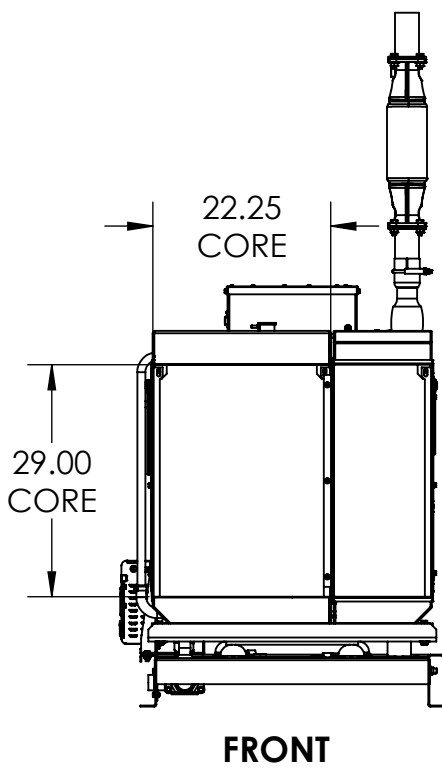
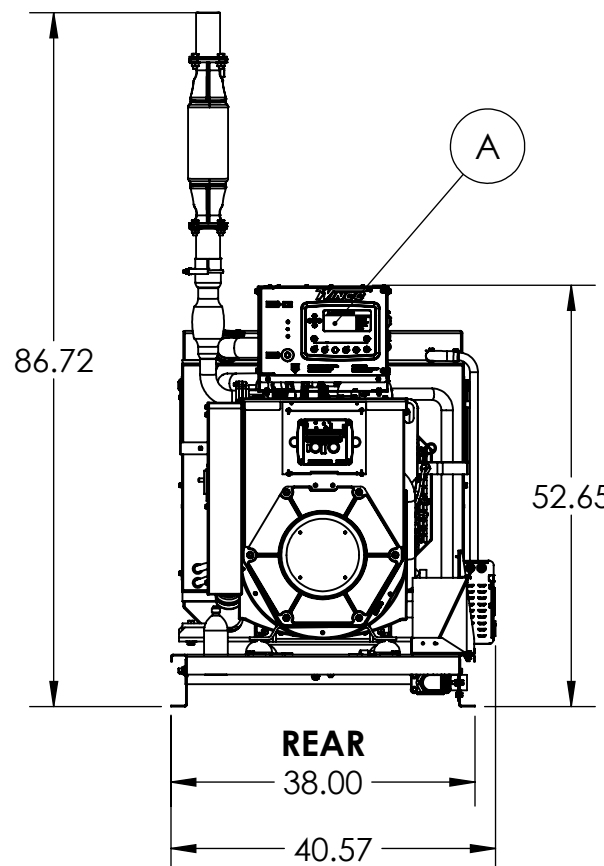
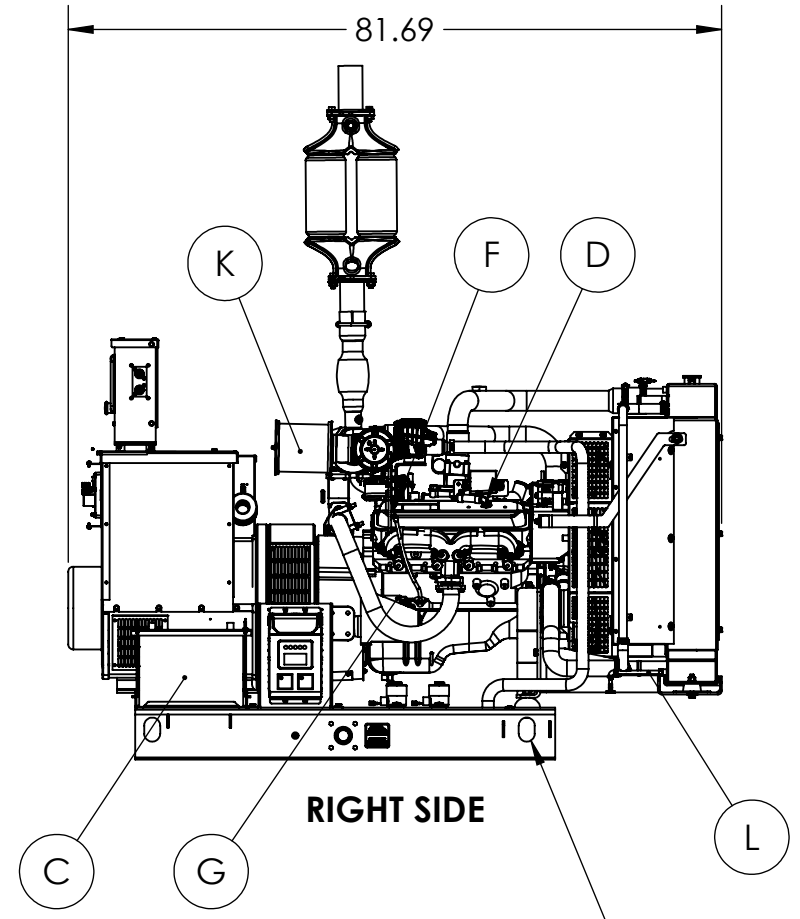

RIGHT SIDE

FRONT

LEFT SIDE

LIFT POINT 3.00 X 2.00
4 PLACES

APPROXIMATE WEIGHT: 2150 LBS

<p>THIS DRAWING CONTAINS PROPRIETARY INFORMATION BELONGING TO WINCO. UNAUTHORIZED USE IS PROHIBITED</p> <p>ALL DIMENSIONS INCH ALL WEIGHT POUNDS</p>	TOLERANCE: +/- 0.0625 DECIMAL +/- 1 DEG ANGULAR	TITLE: OUTLINE DRAWING NARROW SKID
	WEIGHT: LBS	
	MODEL: PSS90	
WINCO ®		PART: O-584 1 of 1