

O-535

REVISIONS					
REV.	IRN	DESCRIPTION	DATE	BY	APP'D
D	CA13666	REMOVED FUEL TANK INFORMATION	12/21/2023	VP	DRC

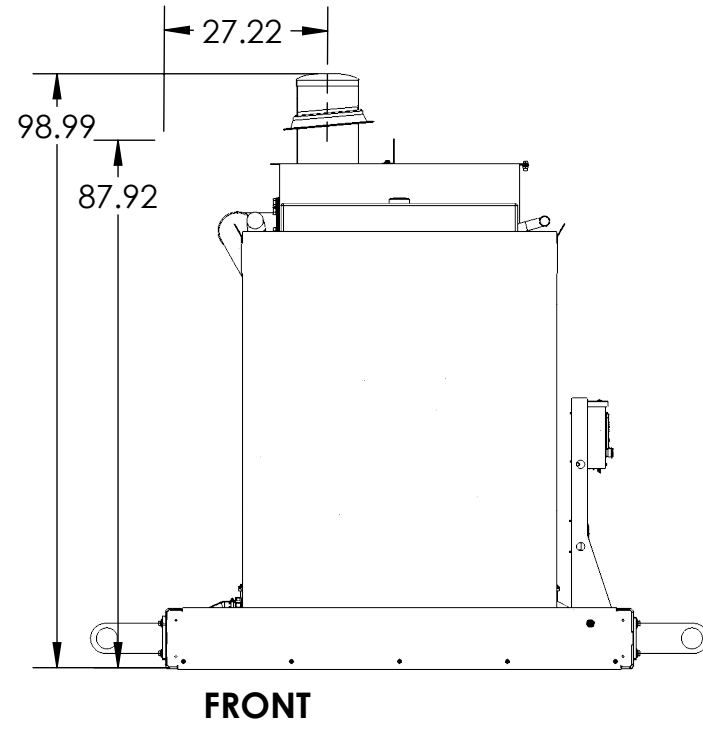

LEFT SIDE

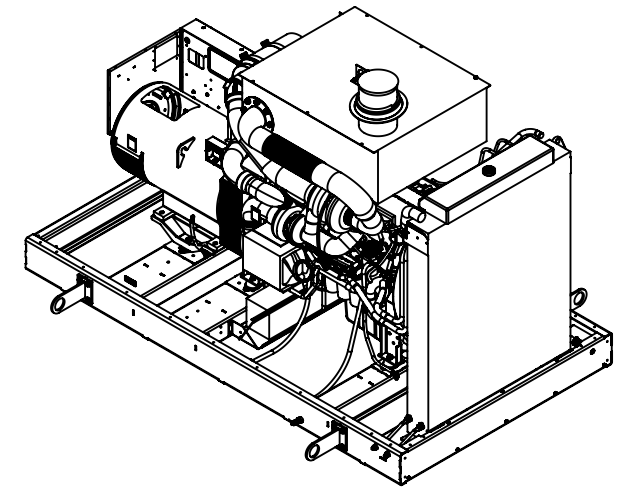
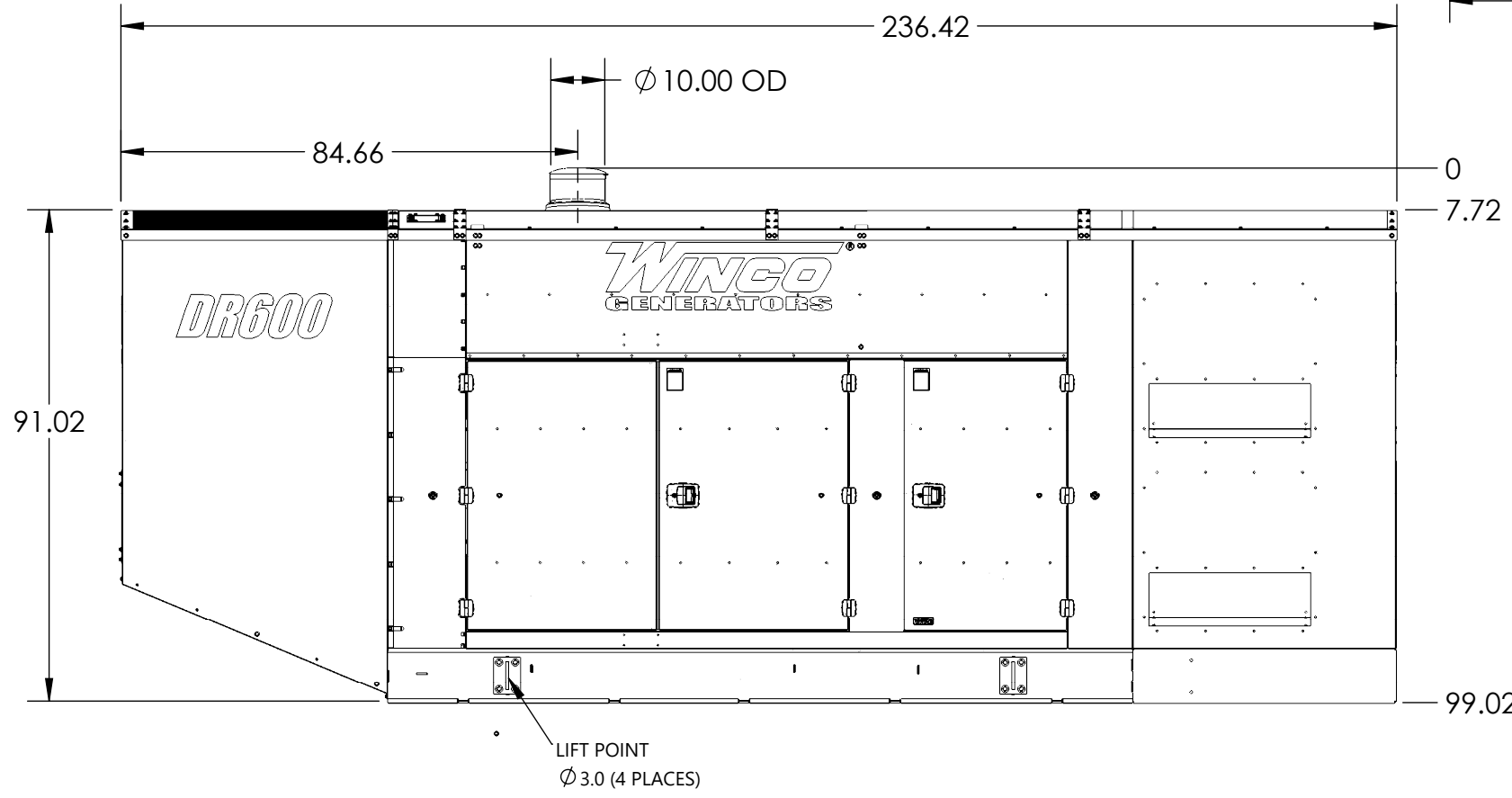
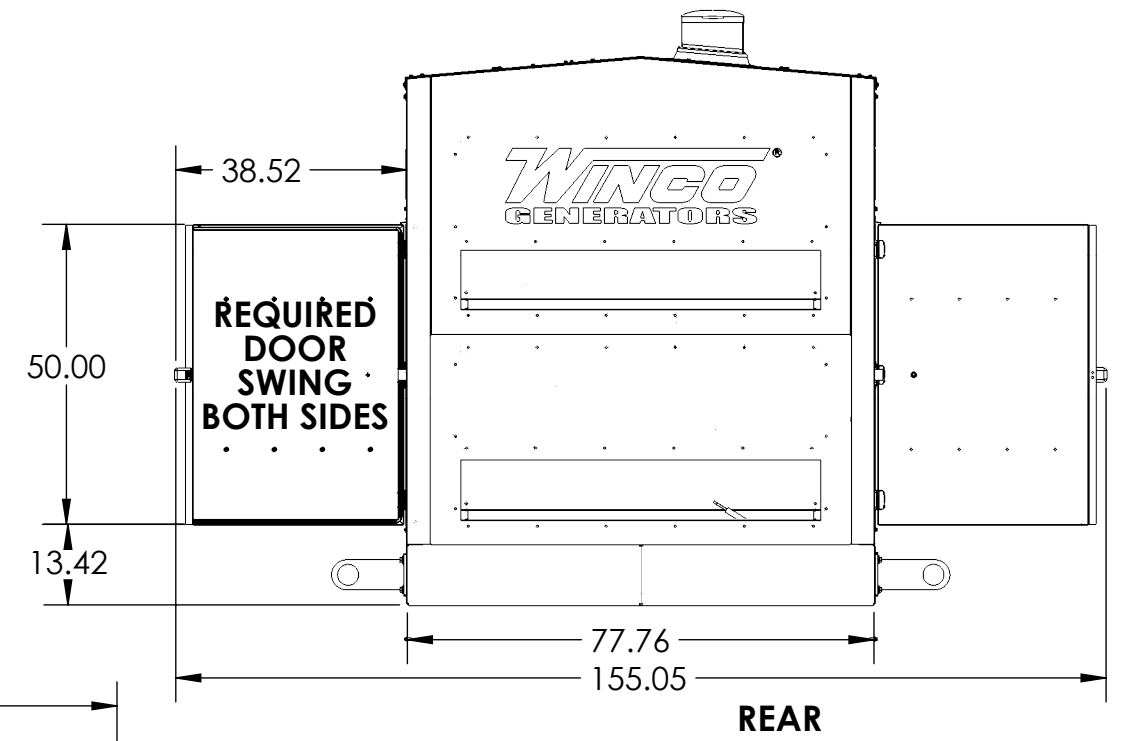

**APPROX. WEIGHT NO TANK (HOUSED): 13,200 LBS**

**\* SEE FUEL TANK DRAWINGS FOR CRITICAL LAYOUT INFORMATION \***

THIS DRAWING CONTAINS PROPRIETARY INFORMATION BELONGING TO WINCO. UNAUTHORIZED USE IS PROHIBITED.	TOLERANCE:	+/- 0.0625 DECIMAL +/- 1 DEG ANGULAR	TITLE:	OUTLINE DRAWING
	WEIGHT:	LBS		
	MODEL:	DR600	PART:	O-535
ALL DIMENSIONS INCH ALL WEIGHT POUNDS	<b>WINCO</b> ®			1 of 2

0-535

# TOP VIEW HOLE PATTERN

REVISIONS					
REV.	IRN	DESCRIPTION	DATE	BY	APP'D
D	CA13666	REMOVED FUEL TANK INFORMATION	12/21/2023	VP	DRC

KEY COMPONENTS	
A	ENGINE CONTROL
B	MAIN LINE CIRCUIT BREAKER
C	OIL FILL
D	OIL DRAIN
E	OIL DIPSTICK
F	OIL FILTER
G	FUEL FILTER
H	FUEL INLET
I	AIR FILTER
J	COOLANT DRAIN
K	COOLANT FILL
L	AVR
M	BATTERY CHARGER
N	BLOCK HEATER
O	BATTERY

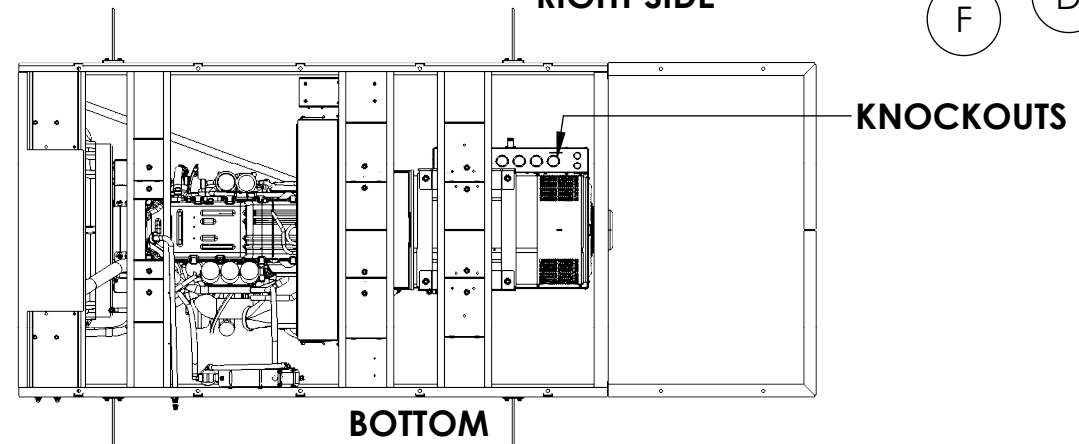
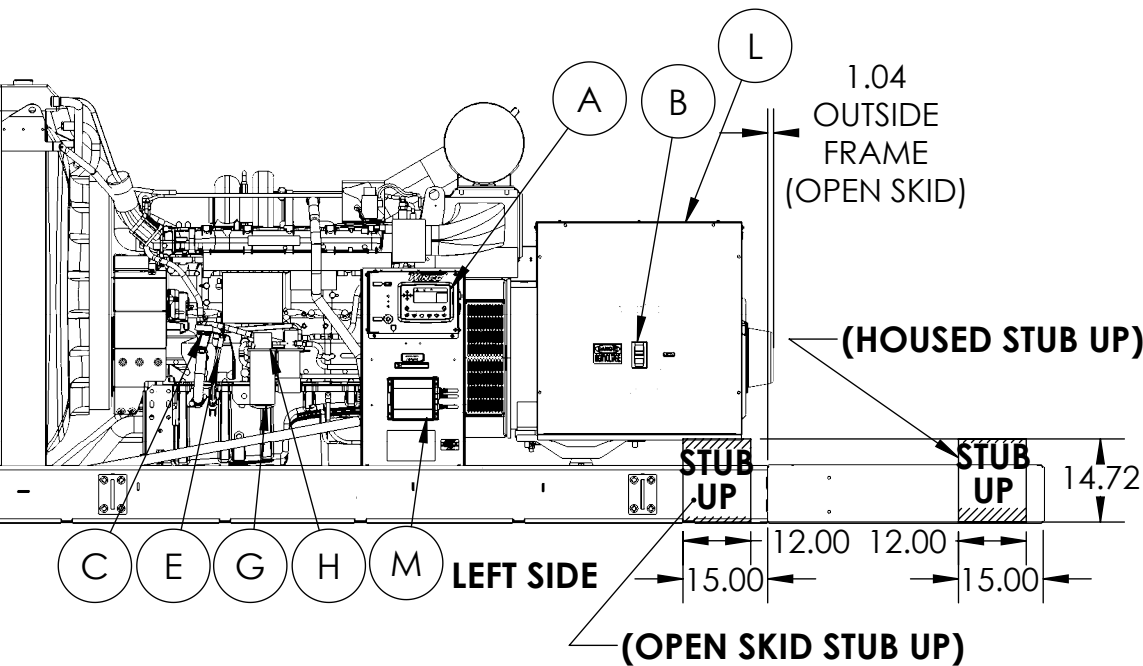
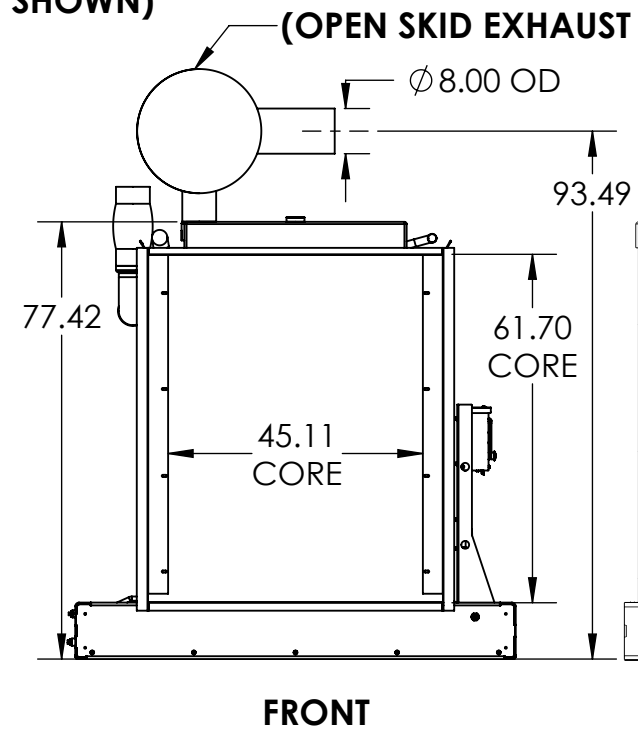
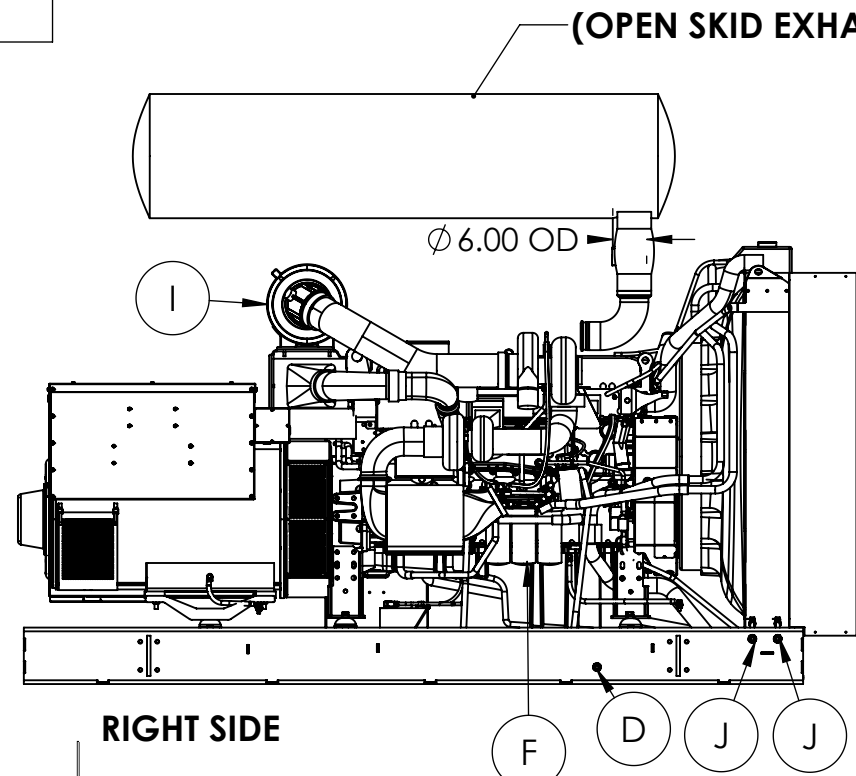
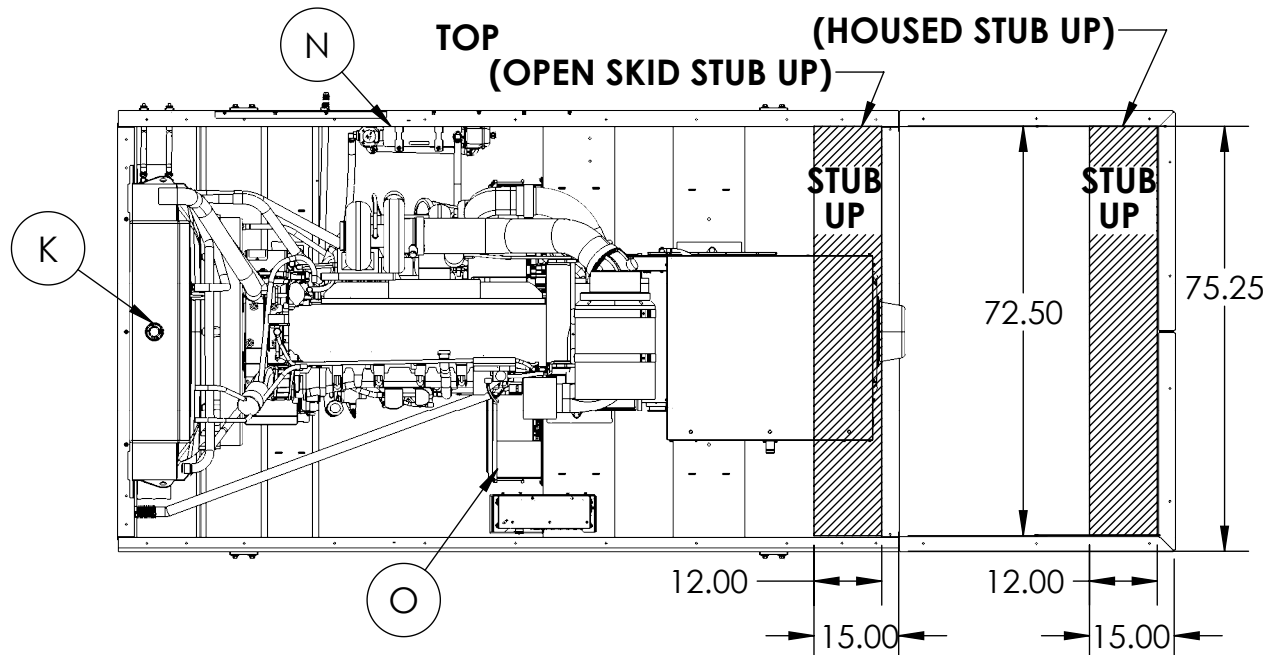
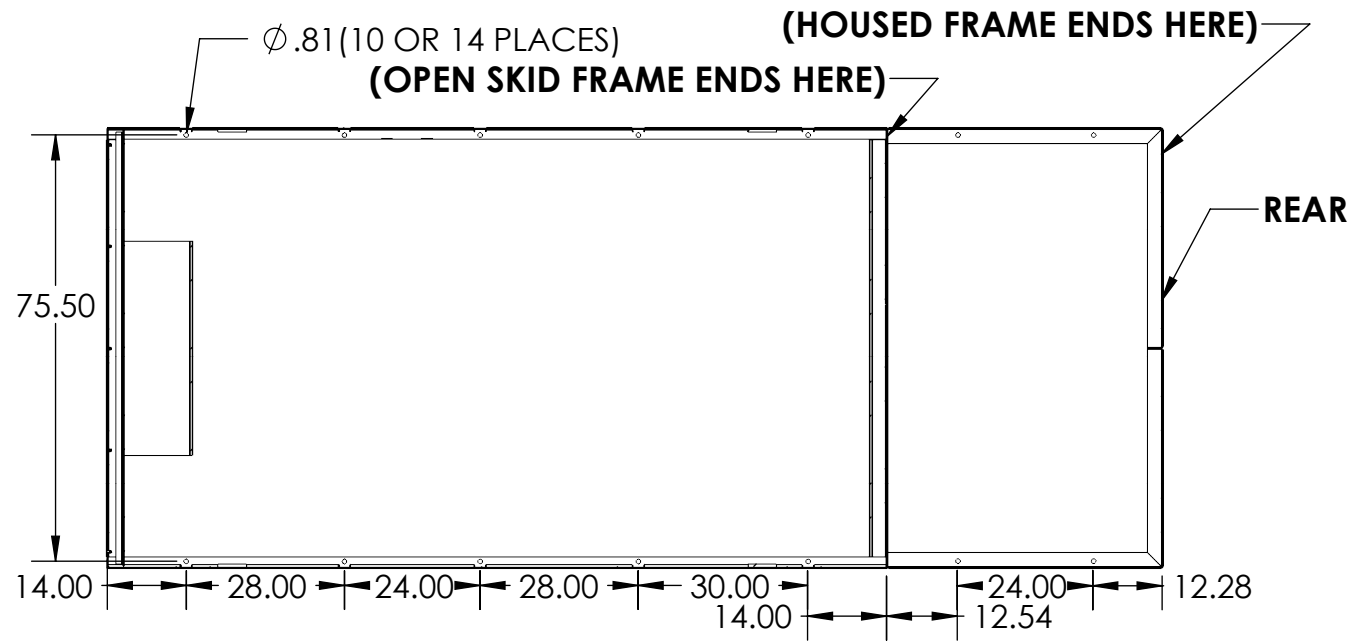

**APPROX. WEIGHT (OPEN SKID): 10,850 LBS**

**3/8 FUEL HOSE**

THIS DRAWING CONTAINS PROPRIETARY INFORMATION BELONGING TO WINCO. UNAUTHORIZED USE IS PROHIBITED.	TOLERANCE:	+/- 0.0625 DECIMAL +/- 1 DEG ANGULAR	TITLE:	OUTLINE DRAWING
	WEIGHT:	LBS	PART: O-535	
	MODEL:	DR600		
ALL DIMENSIONS INCH ALL WEIGHT POUNDS	<b>WINCO</b> ®			