

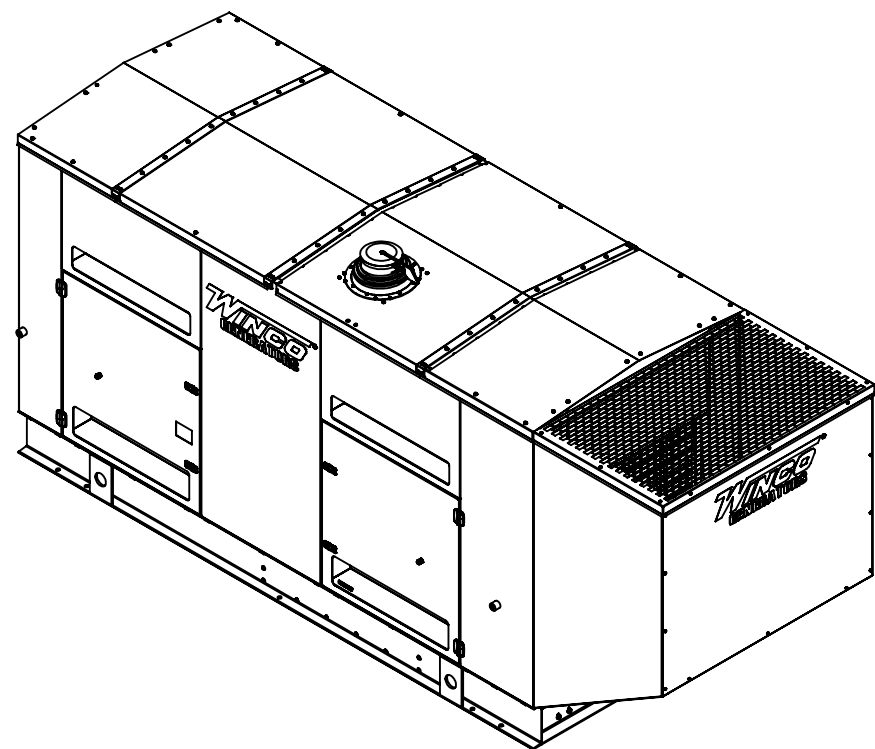

119-O

REVISIONS					
REV.	IRN	DESCRIPTION	DATE	BY	APP'D
A	C2783	ORIGINAL	12/4/2015	SCN	ZJF
B		ADDED CENTER OF GRAVITY INFO	1/22/2019	MML	DRD
C	DR250	UPDATED OUTLINE DRAWING STANDARDS	12/21/2020	MCB	DRC

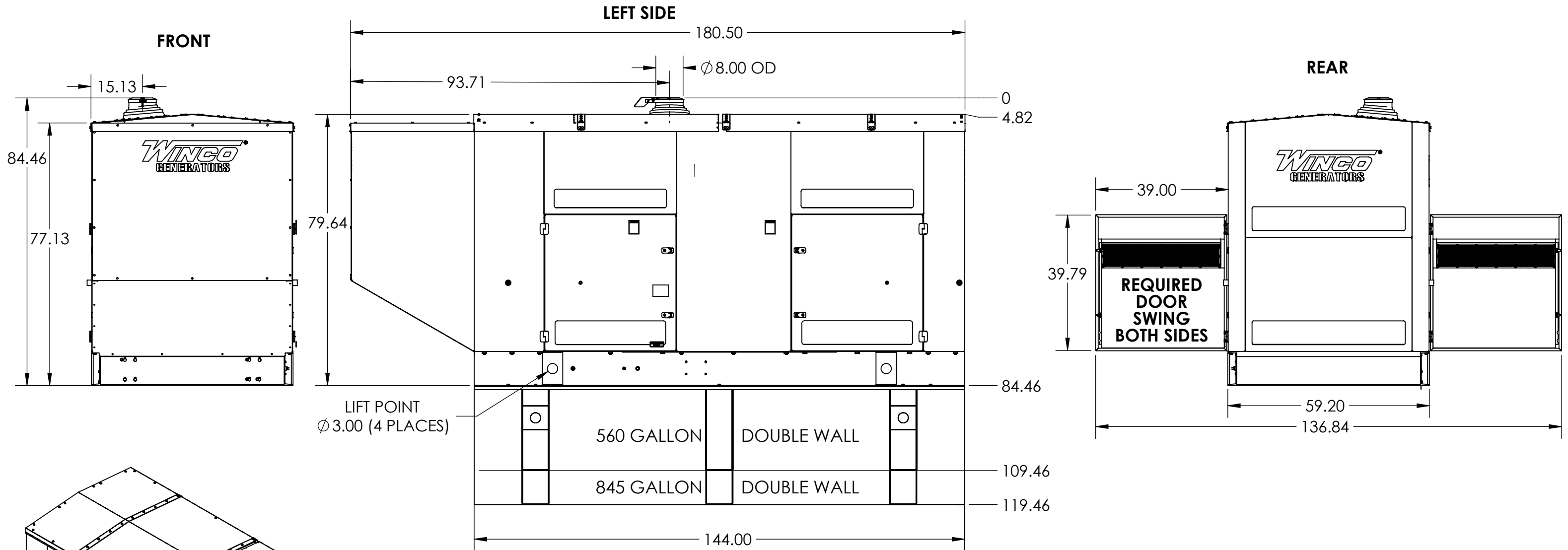

APPROX. WEIGHT NO TANK: 8740 LBS

560 GAL TANK: 2500 LBS
845 GAL TANK: 2600 LBS

 THIS DRAWING CONTAINS PROPRIETARY INFORMATION BELONGING TO WINCO. UNAUTHORIZED USE IS PROHIBITED. ALL DIMENSIONS INCH	DRAWN BY	DATE	CHK'D BY	DATE	ENG APPR.	DATE
	PAK	11/24/2020	---	--/--/----	PAK	07/23/2020
	TOLERANCE:	+/- 0.0625 DECIMAL		TITLE:		
	MODEL:	+/- 1 DEG ANGULAR		OUTLINE DRAWING		
	DR250	TITLE:		PART: O-511 1 of 2		
						

119-O

KEY COMPONENTS

A	ENGINE CONTROL
B	MAIN LINE CIRCUIT BREAKER
C	OIL FILL
D	OIL DRAIN
E	OIL DIPSTICK
F	OIL FILTER
G	FUEL FILTER
H	FUEL INLET
I	AIR FILTER
J	COOLANT DRAIN
K	COOLANT FILL
L	AVR
M	BATTERY CHARGER
N	BLOCK HEATER
O	BATTERY

TOP VIEW HOLE PATTERN

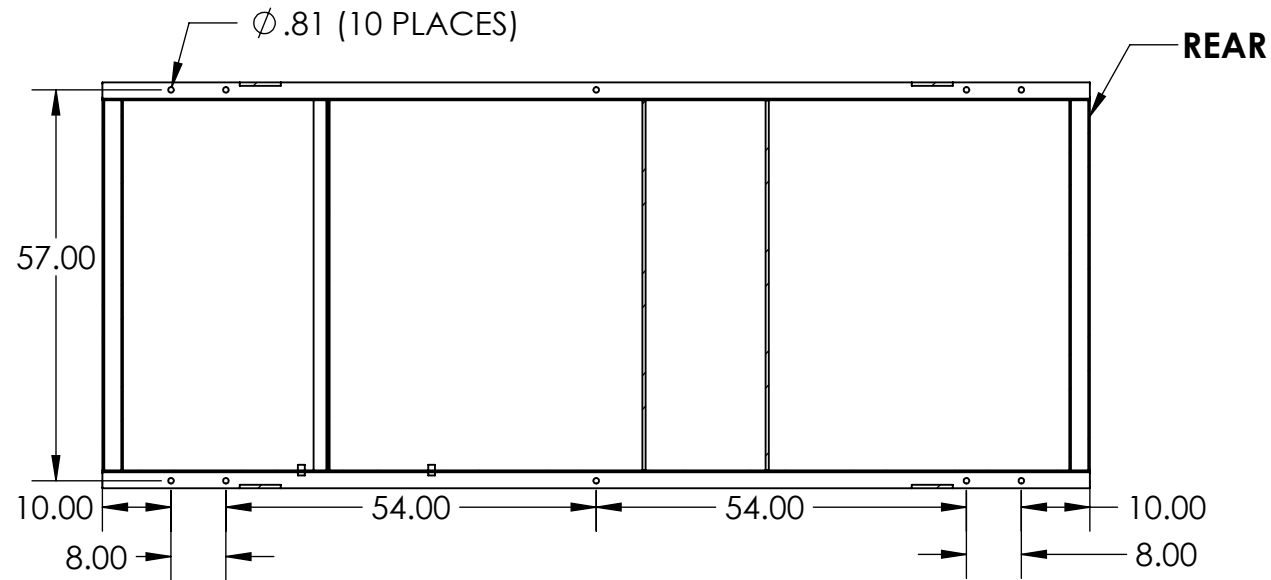

REVISIONS					
REV.	IRN	DESCRIPTION	DATE	BY	APP'D
A	C2783	ORIGINAL	12/4/2015	SCN	ZJF
B		ADDED CENTER OF GRAVITY INFO	1/22/2019	MML	DRD
C	DR250	UPDATED OUTLINE DRAWING STANDARDS	12/21/2020	MCB	DRC

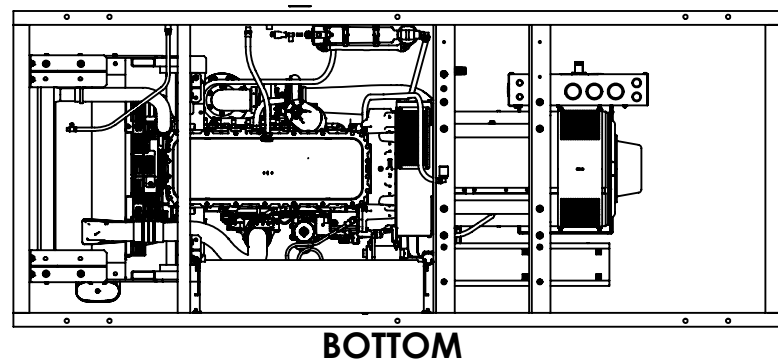
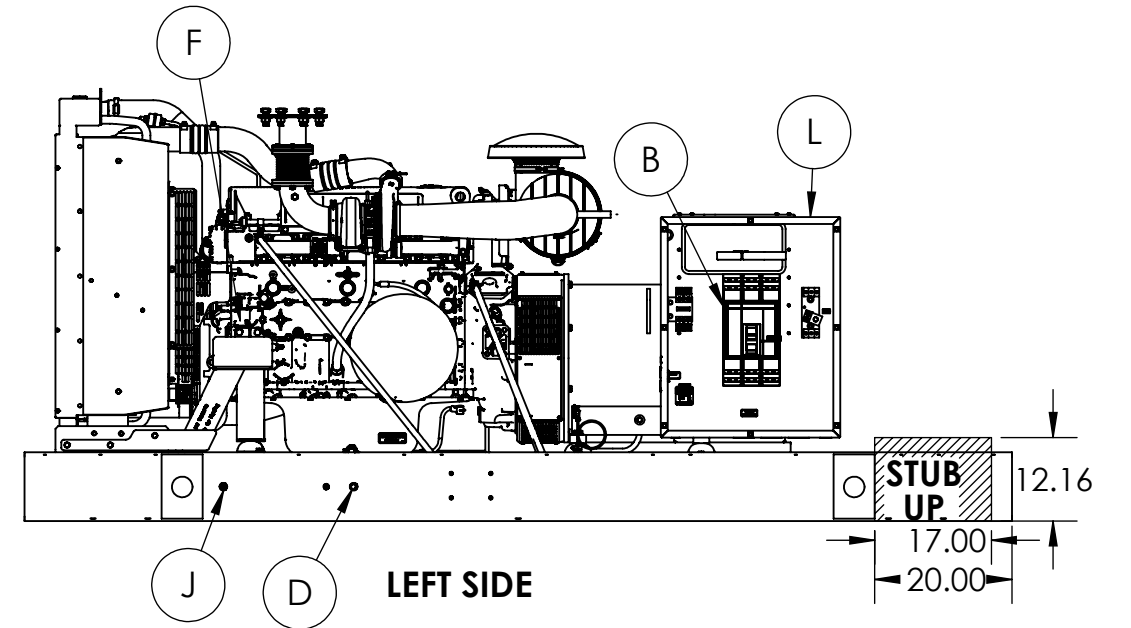
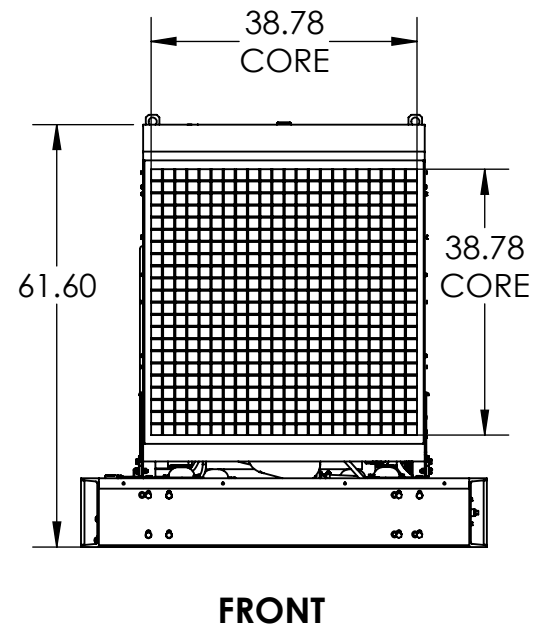
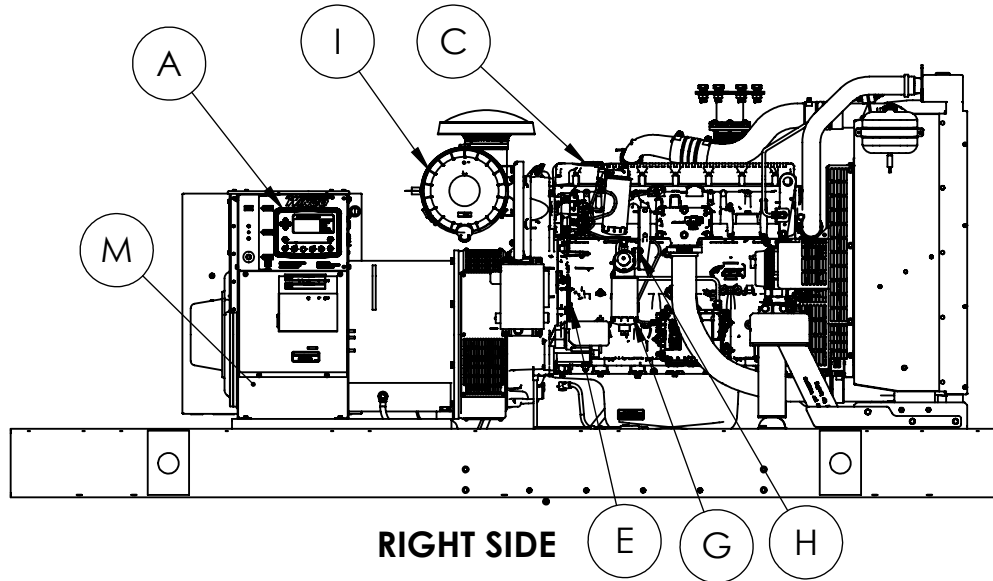
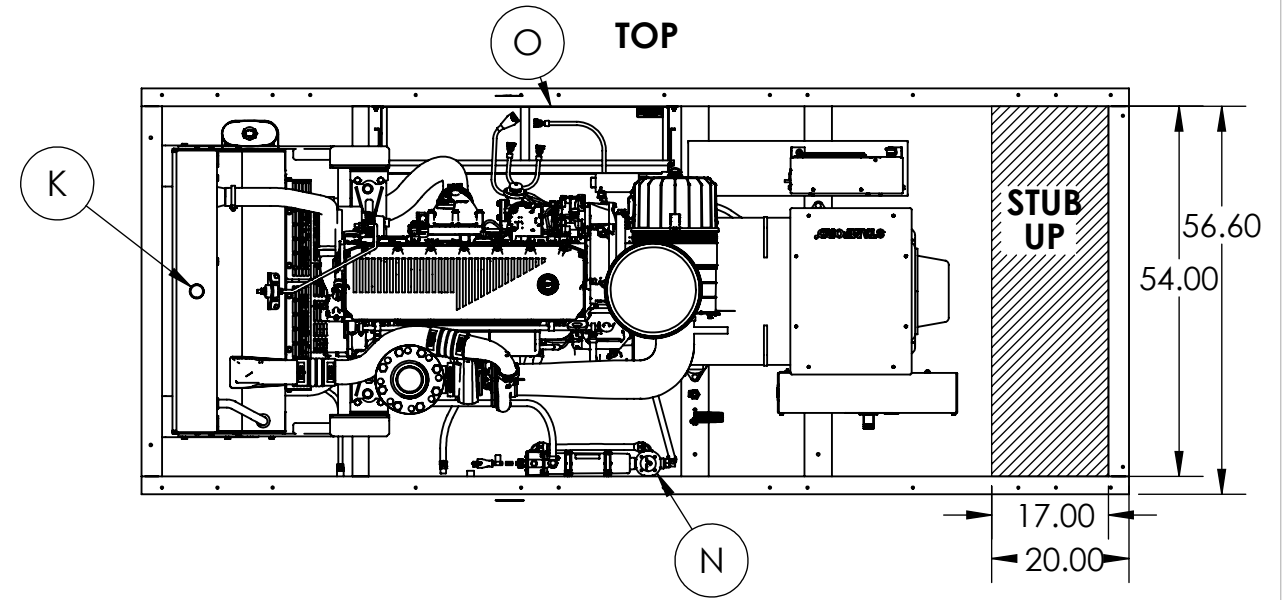

3/8 FUEL HOSE

<p>THIS DRAWING CONTAINS PROPRIETARY INFORMATION BELONGING TO WINCO. UNAUTHORIZED USE IS PROHIBITED.</p> <p>ALL DIMENSIONS INCH</p>	DRAWN BY	DATE	CHK'D BY	DATE	ENG APPR.	DATE
	MML	8/21/2019			PAK	07/23/2020
	TOLERANCE:	+/- 0.0625 DECIMAL		TITLE: OUTLINE DRAWING		
	MODEL:	DR250		PART: O-511 2 of 2		