

O-571

REVISIONS					
REV.	IRN	DESCRIPTION	DATE	BY	APP'D
A	C11643	NEW RELEASE	03/10/2023	VS	DRC

FRONT

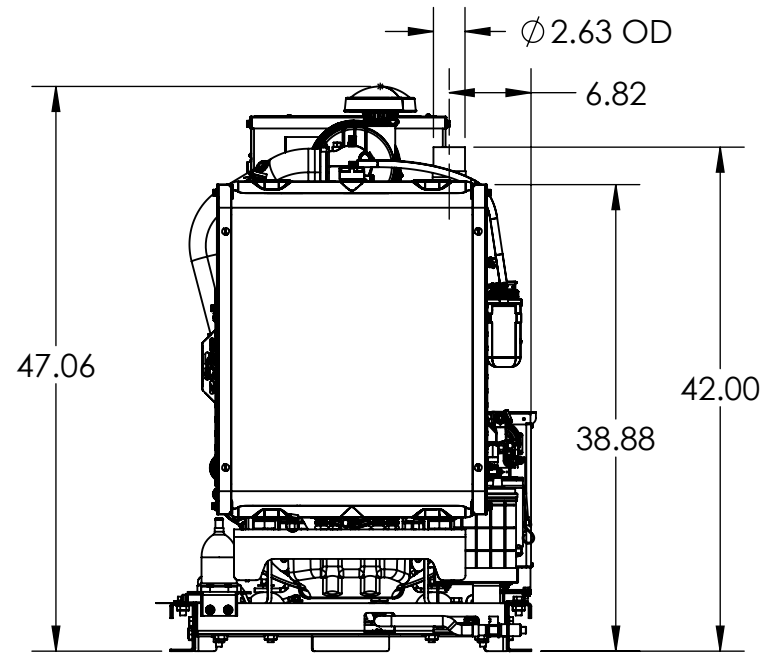

LEFT SIDE

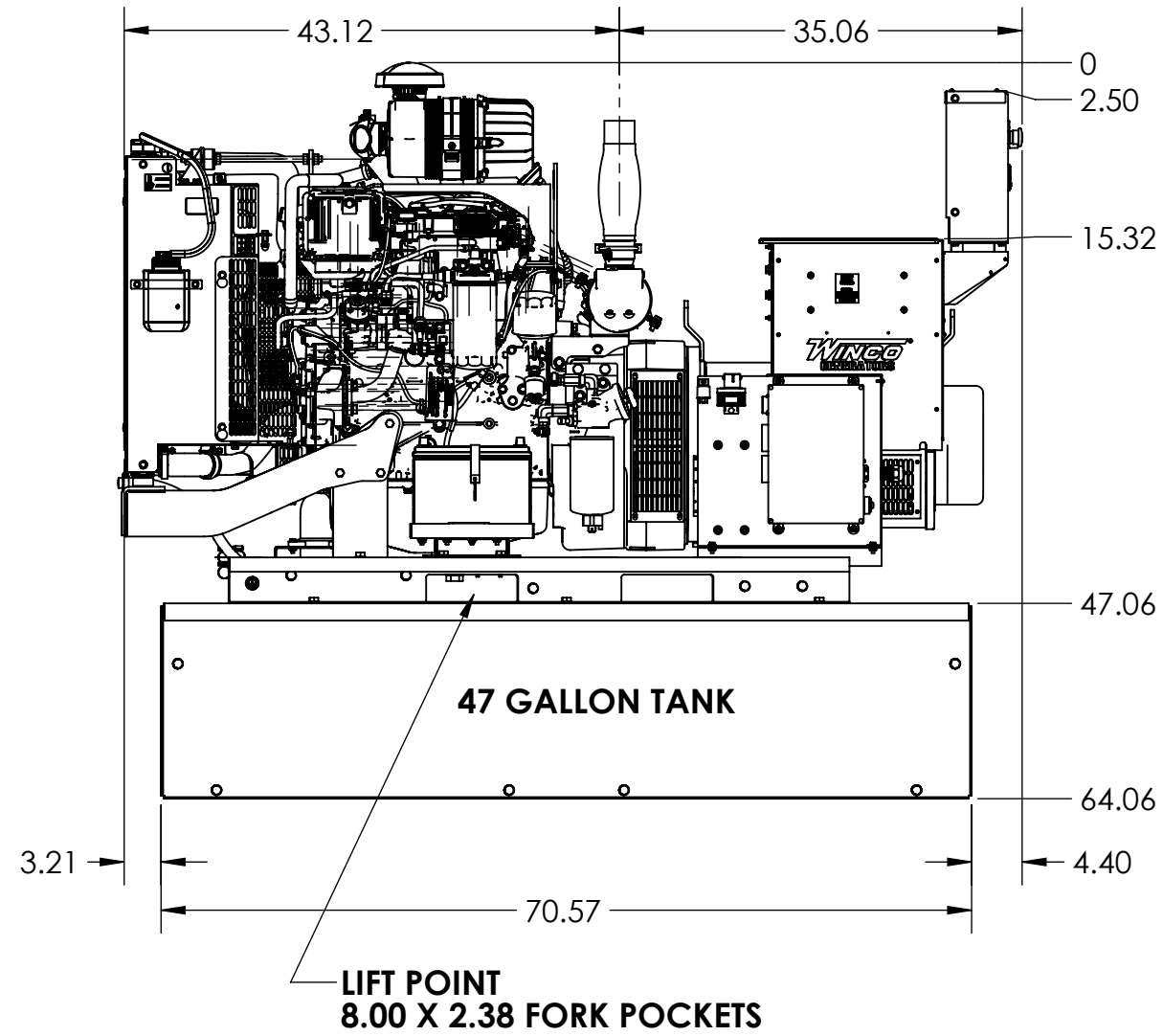

REAR

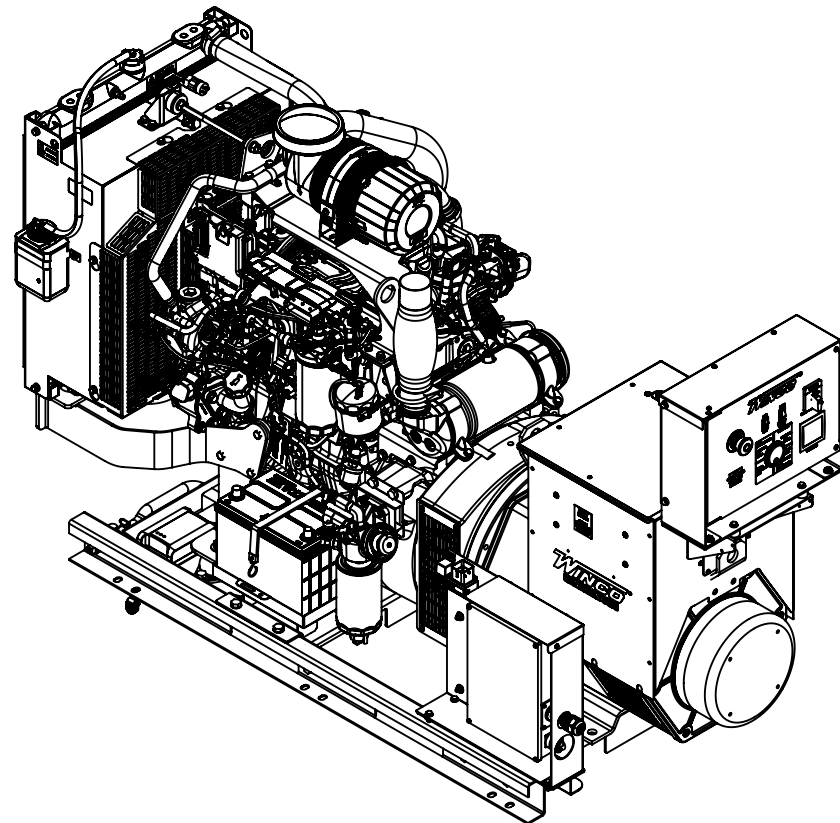
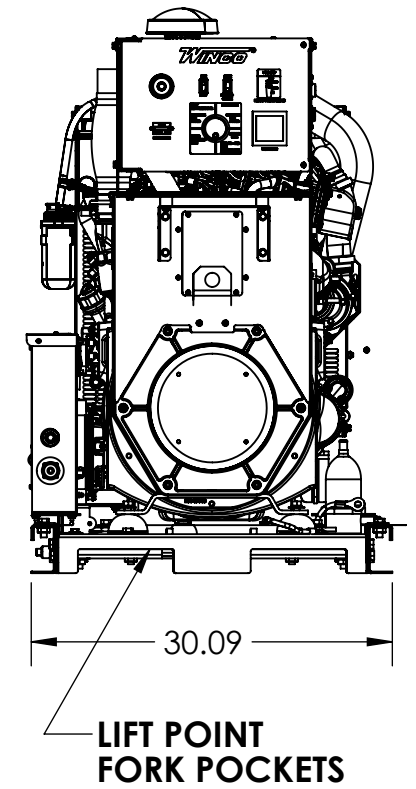

APPROX. WEIGHT NO TANK: 2200 LBS

47 GALLON TANK: 215 LBS

THIS DRAWING CONTAINS PROPRIETARY INFORMATION BELONGING TO WINCO. UNAUTHORIZED USE IS PROHIBITED.	TOLERANCE:	+/- 0.0625 DECIMAL +/- 1 DEG ANGULAR	TITLE: OUTLINE DRAWING
	MODEL:	DE50	
ALL DIMENSIONS INCH	WINCO ®		PART: O-571 1 of 2

175-O

REVISIONS					
REV.	IRN	DESCRIPTION	DATE	BY	APP'D
A	C11643	NEW RELEASE	03/10/2023	VS	DRC

KEY COMPONENTS	
A	ENGINE CONTROL (REVERSIBLE)
B	--
C	OIL FILL
D	OIL DRAIN
E	OIL DIPSTICK
F	OIL FILTER
G	FUEL FILTER
H	FUEL INLET
I	AIR FILTER
J	COOLANT DRAIN
K	COOLANT FILL
L	AVR
M	BATTERY CHARGER
N	BLOCK HEATER
O	BATTERY

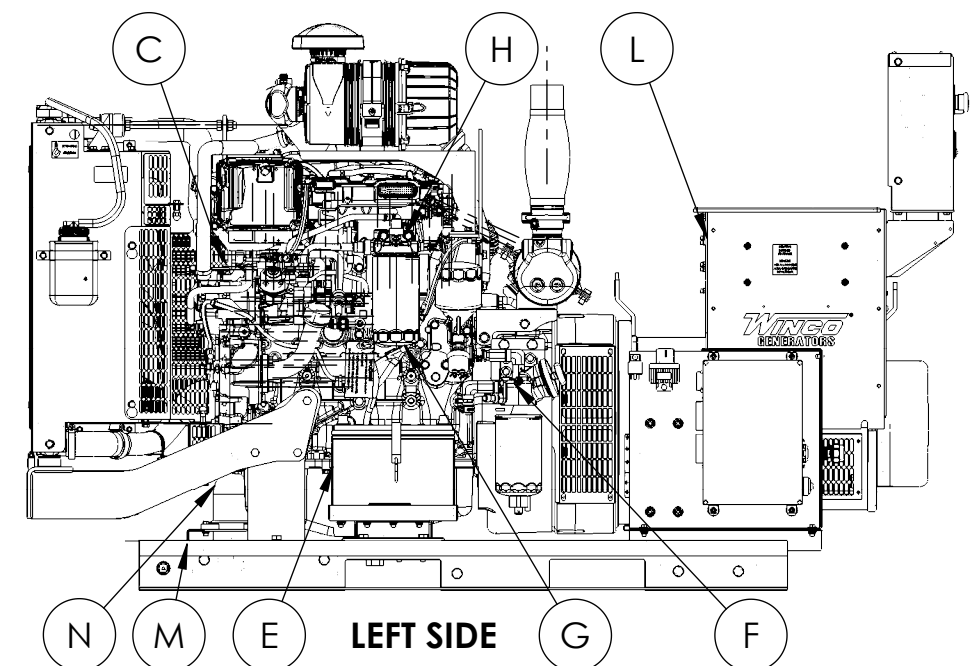
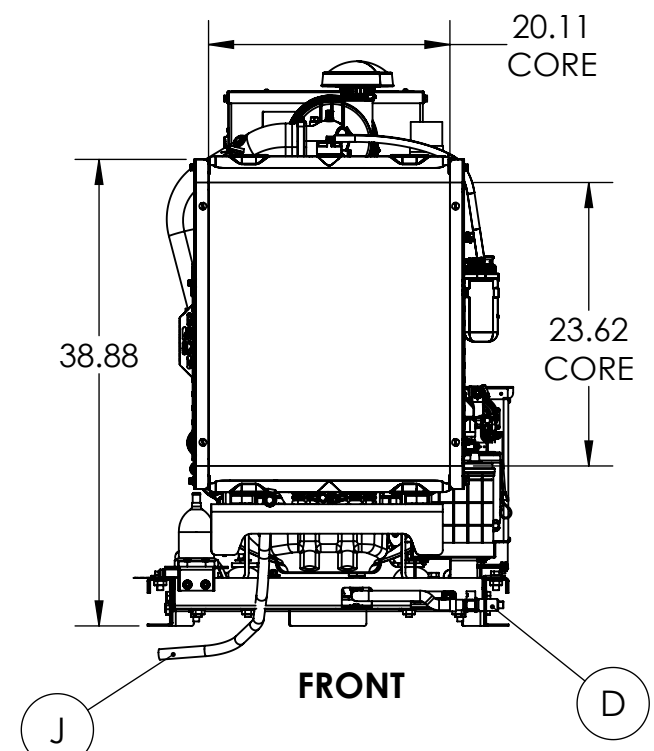
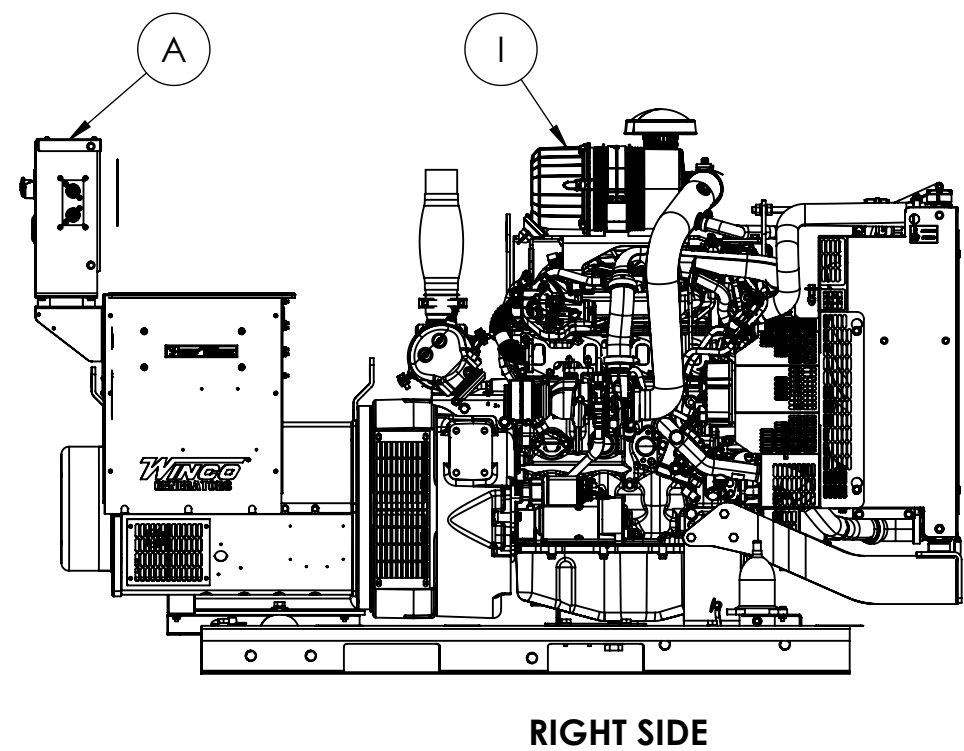
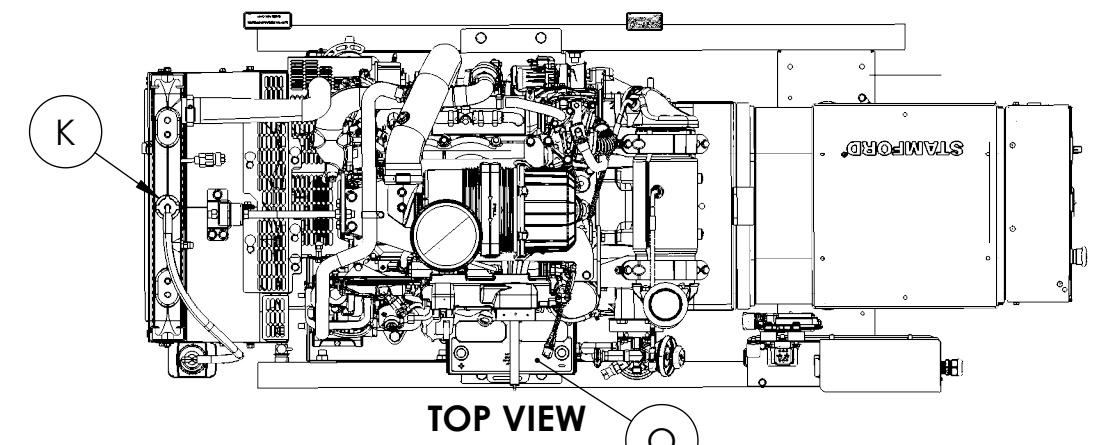
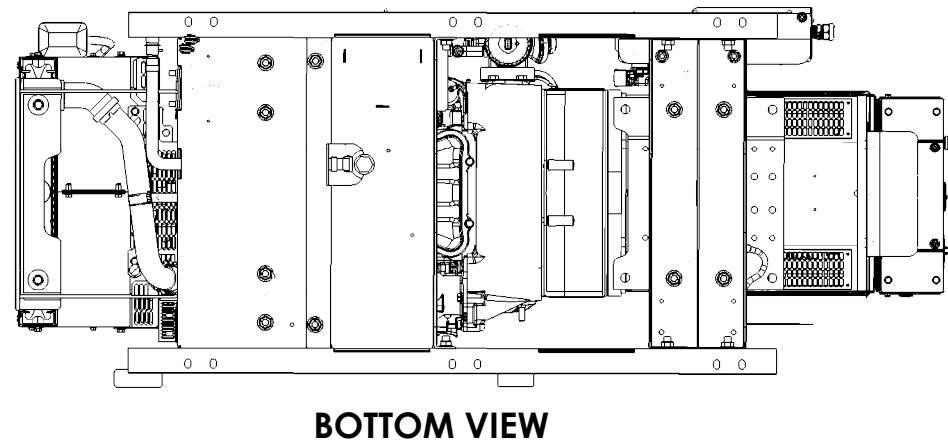
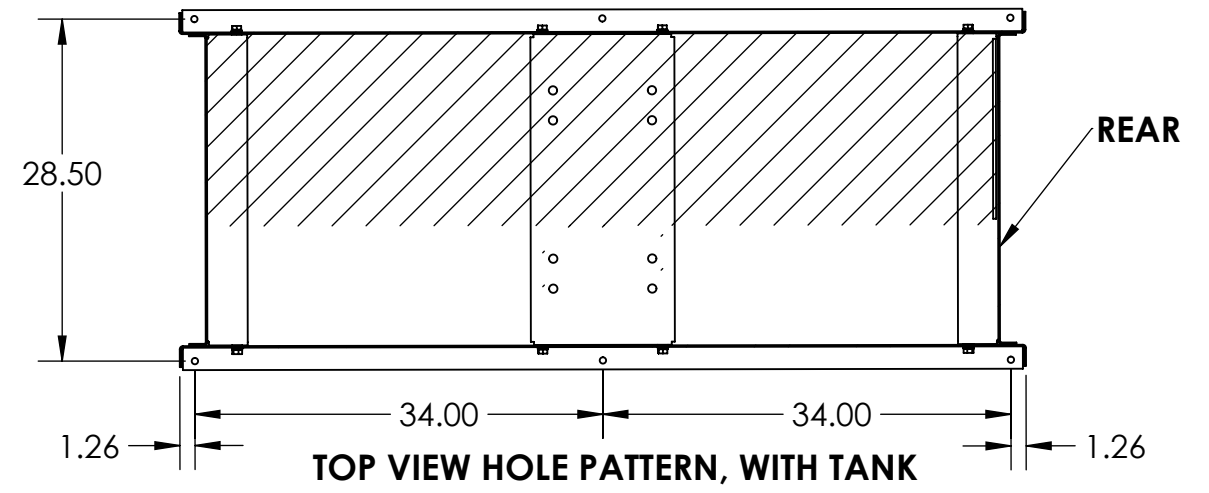
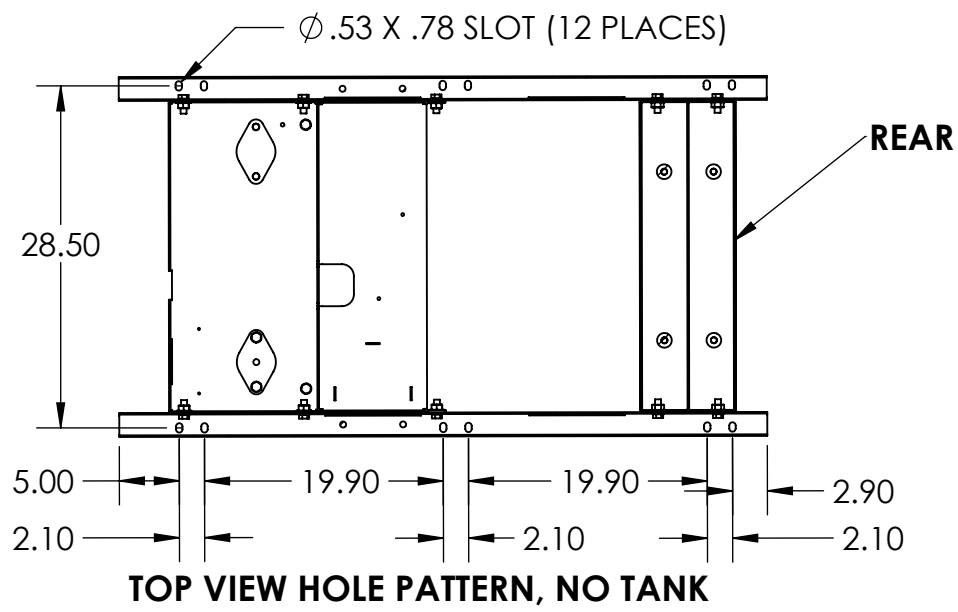

INDOOR UNIT: STUB UP ELECTRICAL COMING FROM TOP
THIS UNIT HAS A REVERSIBLE CONTROLLER

THIS DRAWING CONTAINS PROPRIETARY INFORMATION BELONGING TO WINCO. UNAUTHORIZED USE IS PROHIBITED.	TOLERANCE:	+/- 0.0625 DECIMAL +/- 1 DEG ANGULAR	TITLE: OUTLINE DRAWING
	MODEL:	DE50	
ALL DIMESNIONS INCH	WINCO ®		PART: O-571