

O-525

TOP SIDE

REVISIONS					
REV.	IRN	DESCRIPTION	DATE	BY	APPROVED
A	P307	ORIGINAL	8/15/2019	TDS	PAK
B	12244	CORRECTED COMPONENT DESCRIPTION	6/15/2021	SJM	PAK

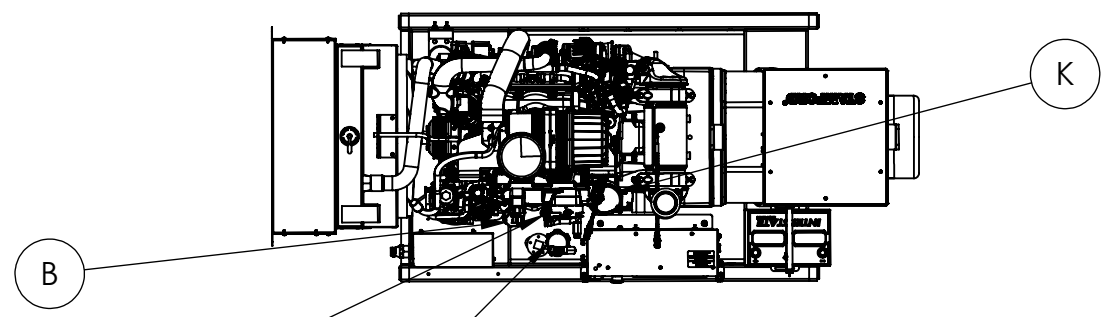

FRONT SIDE

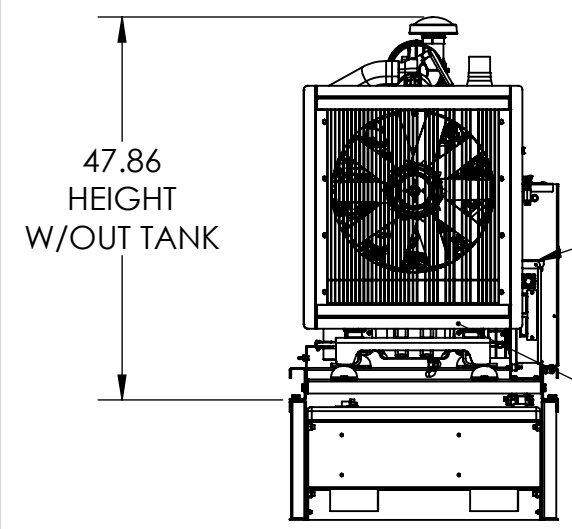

LEFT SIDE

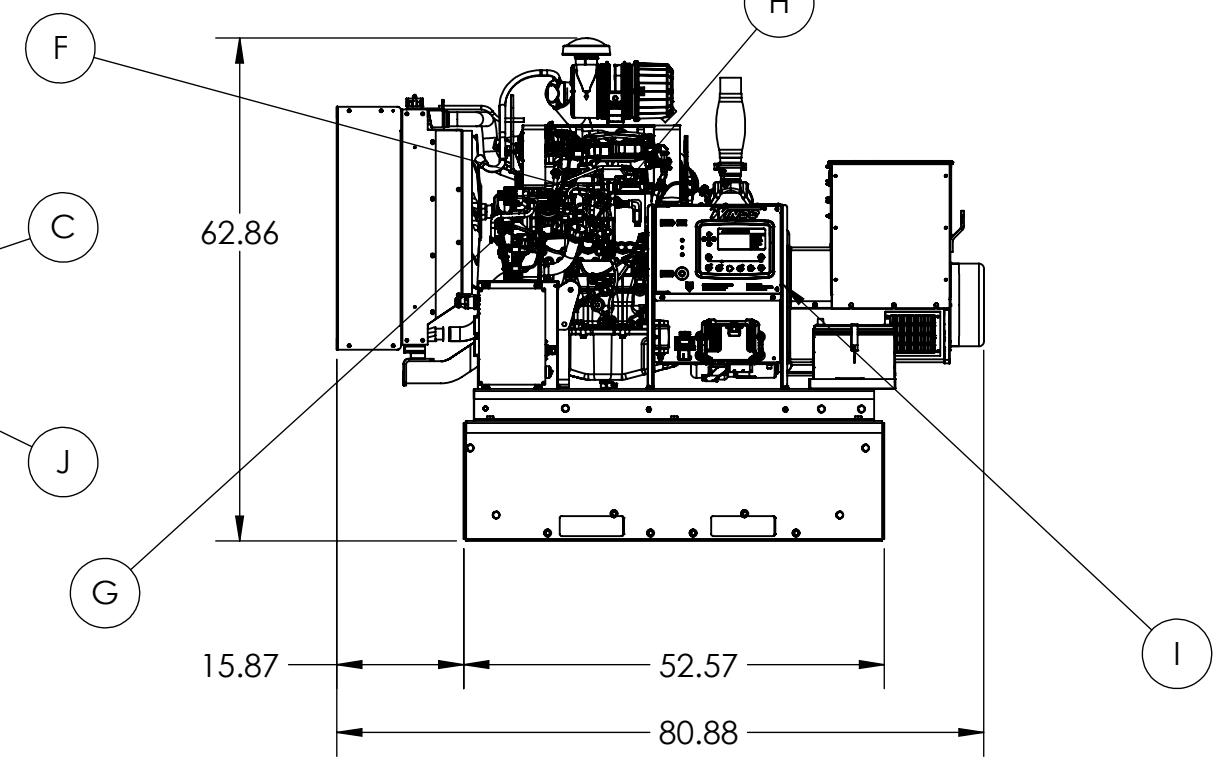

BACK SIDE

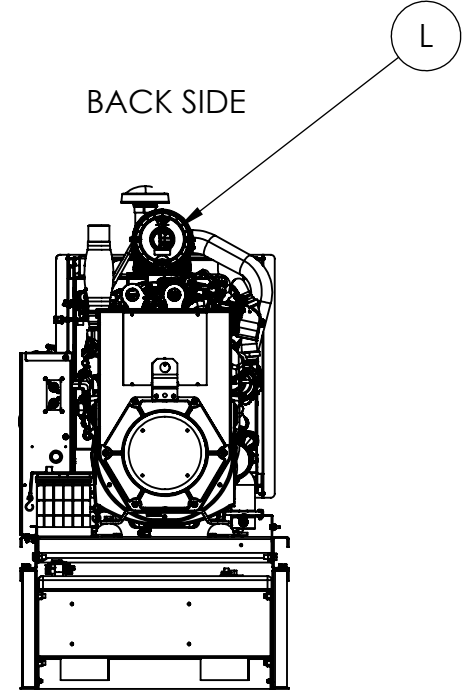

RIGHT SIDE

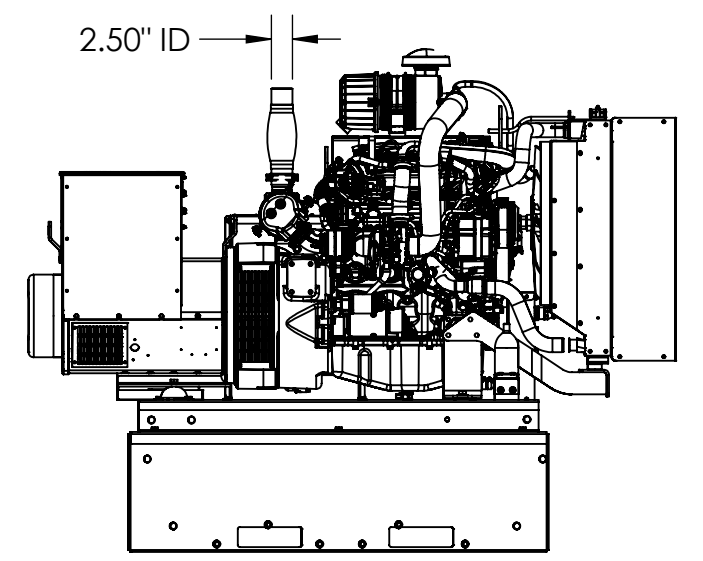

KEY COMPONENTS	
A	FUEL FILL
B	OIL FILL
C	LEAD CONNECTION POINT
D	DIP STICK
E	FUEL INLET
F	FUEL FILTER
G	FUEL RETURN
H	OVERFLOW
I	CONTROLS
J	RADIATOR DRAIN
K	OIL FILTER
L	AIR FILTER

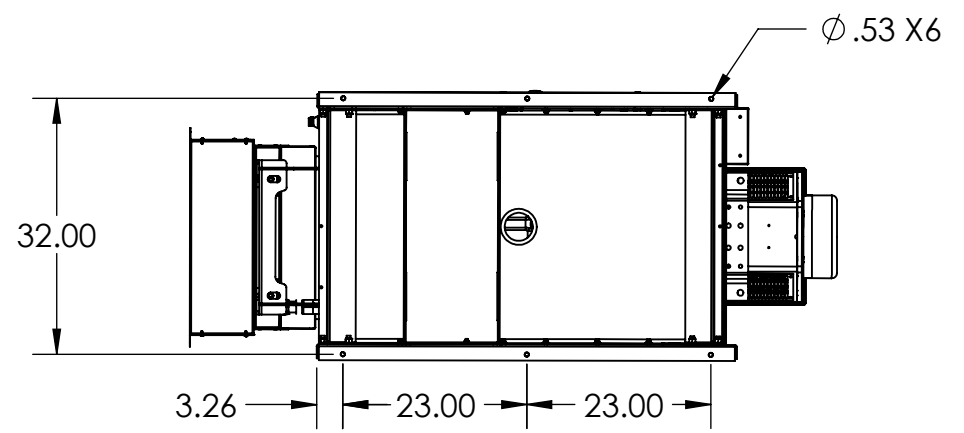

UNDERSIDE VIEW (UNIT MOUNTS)
BOLT PATTERN IS IDENTICAL WITH
OR WITHOUT SKID

<p>THIS DRAWING CONTAINS PROPRIETARY INFORMATION BELONGING TO WINCO. UNAUTHORIZED USE IS PROHIBITED</p>	DRAWN BY TDS	DATE 8/15/2019	CHK'D BY	DATE	ENG APPR. PAK	DATE 12/3/2019
	TOLERANCE:	+/- 0.25" (UNLESS SPECIFIED)		TITLE: DE50 OUTLINE DRAWING		
	WEIGHT:	376.72 LBS		PART: O-525		
	MATERIAL: MODEL:	SEE TABLE DE50				