

6E0-66191

REVISIONS					
REV.	IRN	DESCRIPTION	DATE	BY	APP'D
D	7699	ADDED INSTRUCTION SHEET	9/7/2017	SJM	DRC
E	7840	ADDED (4) 23558-000	10/3/2017	SJM	DRC

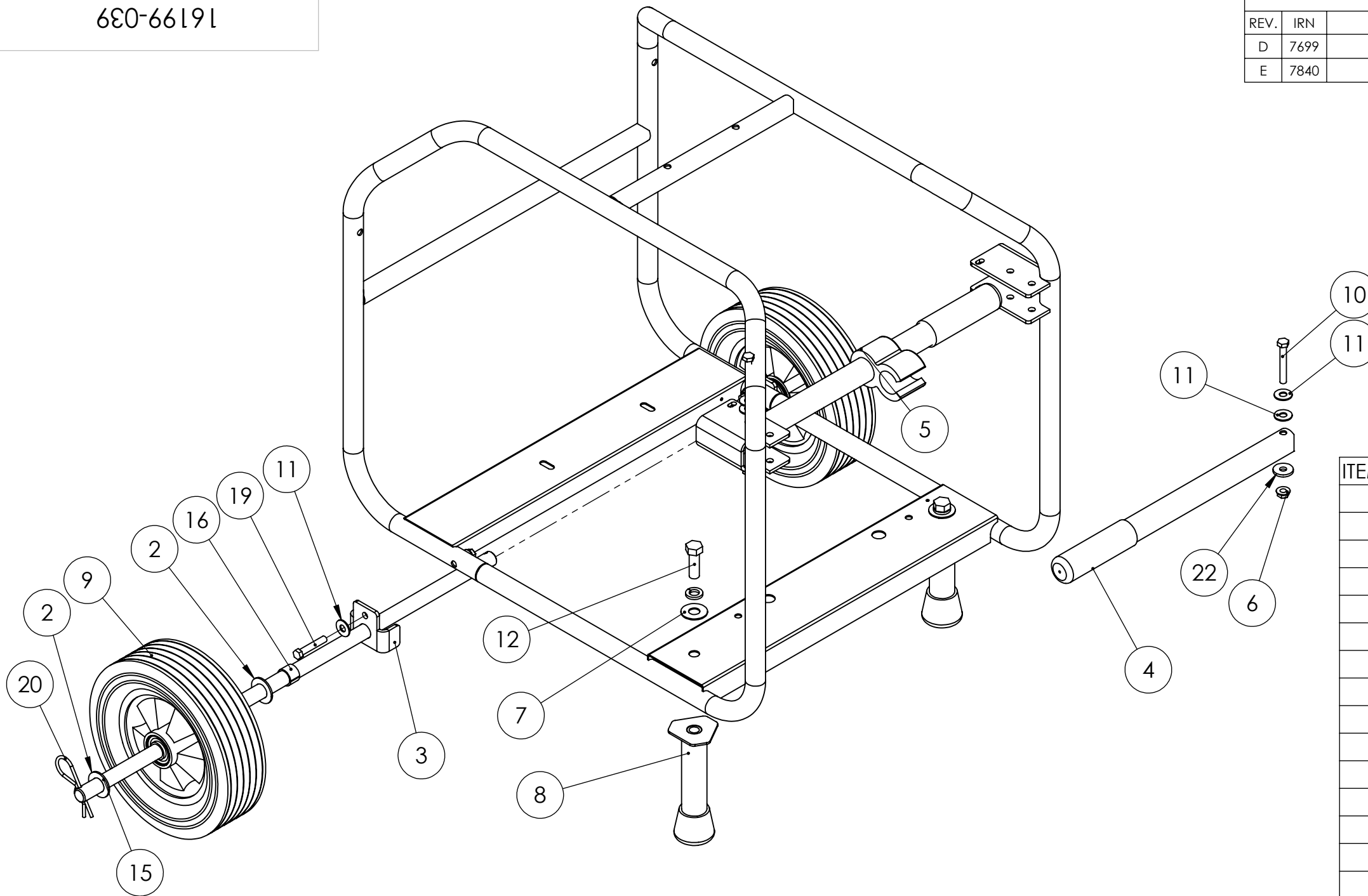

ITEM NO.	PartNo	DESCRIPTION	QTY.
1	100047-777	29 X 11 X 5 CARTON	1
2	* 1178-000	FLAT WASHER .760 X 1.375 X .0897	4
3	* 15775-027	AXLE BRACKET	2
4	16197-004	HANDLE	1
5	16197-005	HANDLE WITH CUP	1
6	* 16249-000	.3125-18 FLANGE	4
7	* 21867-000	FLAT WASHER	2
8	383000-036	WELDED FOOT	2
9	43657-008	WHEEL 10" DIA X 3" HARD RUBBER	2
10	* 471-000	5/16-18 X 2.25	2
11	* 526-000	5/16 FLAT WASHER	8
12	* 57580-000	1/2-13 X 1.5 HHB	2
14	* 636-000	LOCKWASHER 1/2 SPLIT	2
15	64326-028	AXLE .75 X 29.3125"	1
16	* 64688-009	SPACER AXLE STUB .75X .625IN	2
17	6505-21	BOX LABEL	1
18	* 91372-000	PLASTIC BAG	1
19	* 9416-000	HHCS .3125-18X1.75 GR5	2
20	* 97883-001	PIN, COTTER, HAIR,	2
21	* 16199-1391	INSTRUCTION SHEET	1
22	* 23558-000	FLAT WSHR. .3435 X 1 .125 THK. ZINC	4

* ITEMS IN PARTS BAG 16199-139

<p>THIS DRAWING CONTAINS PROPRIETARY INFORMATION BELONGING TO WINCO. UNAUTHORIZED USE IS PROHIBITED.</p> <p>ALL DIMENSIONS INCH</p>	DRAWN BY	DATE	CHK'D BY	DATE	ENG APPR.	DATE
	SJM	2/1/2017			DRC	2/24/2017
	TOLERANCE:	+/- 0.0625 DECIMAL		TITLE:		
	MODEL:	+/- 1 DEG ANGULAR		2 WHEEL DOLLY KIT		
	WARRIOR		PART:		16199-039 1 of 1	