

LSA 37 - 2 & 4 POLE - ACC ALTERNATORS

Installation and maintenance

LSA 37 - 2 & 4 POLE - ACC ALTERNATORS

This manual concerns the alternator which you have just purchased.

The latest addition to a whole new generation of alternators, this range benefits from the experience of the leading manufacturer worldwide, using advanced technology and incorporating strict quality control.

SAFETY MEASURES

Before using your machine for the first time, it is important to read the whole of this installation and maintenance manual.

All necessary operations and interventions on this machine must be performed by a qualified technician.

Our technical support service will be pleased to provide any additional information you may require.

The various operations described in this manual are accompanied by recommendations or symbols to alert the user to potential risks of accidents. It is vital that you understand and take notice of the following warning symbols.

ATTENTION

Warning symbol for an operation capable of damaging or destroying the machine or surrounding equipment.



Warning symbol for general danger to personnel.



Warning symbol for electrical danger to personnel.

Note : LEROY-SOMER reserves the right to modify the characteristics of its products at any time in order to incorporate the latest technological developments. The information contained in this document may therefore be changed without notice.

We wish to draw your attention to the contents of this maintenance manual. By following certain important points during installation, use and servicing of your alternator, you can look forward to many years of trouble-free operation.

WARNING SYMBOLS

A set of self-adhesive stickers depicting the various warning symbols is included with this maintenance manual. They should be positioned as shown in the drawing below once the machine has been fully installed.

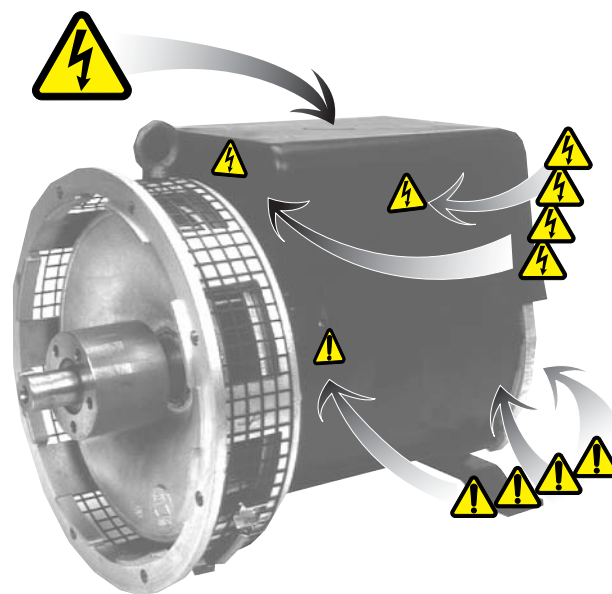

Copyright 2002 : MOTEURS LEROY-SOMER

This document is the property of :

MOTEURS LEROY-SOMER

It may not be reproduced in any form without prior authorization.

All brands and models have been registered and patents applied for.

LSA 37 - 2 & 4 POLE - ACC

ALTERNATORS

CONTENTS

1 - RECEIPT

1.1 - Standards and safety measures	4
1.2 - Checks	4
1.3 - Identification	4
1.4 - Storage	4

2 - TECHNICAL CHARACTERISTICS

2.1 - Electrical characteristics	5
2.2 - Mechanical characteristics	5

3 - INSTALLATION - COMMISSIONING

3.1 - Assembly	6
3.2 - Inspection prior to first use	6
3.3 - Terminal connection diagram	7
3.4 - Commissioning	7

4 - SERVICING - MAINTENANCE

4.1 - Safety measures	8
4.2 - Regular maintenance	8
4.3 - Fault detection	8
4.4 - Mechanical defects	9
4.5 - Electrical faults	9
4.6 - Dismantling, reassembly	11

5 - SPARE PARTS

5.1 - First maintenance parts	13
5.2 - Technical support service	13
5.3 - Parts list, exploded view,	13

LSA 37 - 2 & 4 POLE - ACC

ALTERNATORS

RECEIPT

1 - RECEIPT

1.1 - Standards and safety measures

Our alternators comply with most international standards and are compatible with :

- the recommendations of the

International Electrotechnical Commission

IEC 34-1, (EN 60034).

- the recommendations of the

International Standards Organisation ISO 8528.

- the European Community directive 89/336/EEC on Electromagnetic Compatibility (EMC).

- **the European Community directives 73/23/EEC and 93/68/EEC (Low Voltage Directive).**

They are CE marked with regard to the LVD (Low Voltage Directive) in their role as a machine component. A declaration of incorporation can be supplied on request.

Before using your generator for the first time, read carefully the contents of this installation and maintenance manual, supplied with the machine. All operations performed on the generator should be undertaken by qualified personnel with specialist training in the commissioning, servicing and maintenance of electrical and mechanical machinery. This maintenance manual should be retained for the whole of the machine's life and be handed over with the contractual file. The various operations described in this manual are accompanied by recommendations or symbols to alert the user to potential risks of accidents. It is vital that you understand and take notice of the different warning symbols.

1.2 - Inspection

On receipt of your alternator, check that it has not suffered any damage in transit. If there are obvious signs of knocks, contact the transporter (you may be able to claim on their insurance) and after a visual check, turn the machine by hand to detect any malfunction.

1.3 - Identification

The alternator is identified by means of a nameplate fixed on the frame.

Make sure that the nameplate on the machine conforms to your order.

The machine name is defined according to various criteria (see below).

Example of description for : **LSA 37 M7 A1/2**

- LSA : name used in the PARTNER range
 - M : Marine / C : Cogeneration / T : Telecommunications.
- 37 : machine type
- M7 : model
- A : field excitation system (ACC)
- 1/2 : winding number / number of poles.

1.3.1 - Nameplate

So that you can identify your machine quickly and accurately, we suggest you fill in its specifications on the nameplate below.

1.4 - Storage

Prior to commissioning, machines should be stored :

- Away from humidity : in conditions of relative humidity of more than 90%, the machine insulation can drop very rapidly, to just above zero at around 100%; monitor the state of the anti-rust protection on unpainted parts.

For storage over an extended period, the machine can be placed in a sealed enclosure (heatshrink plastic for example) with dehydrating sachets inside, away from significant and frequent variations in temperature to avoid the risk of condensation during storage.

- If the area is affected by vibration, try to reduce the effect of these vibrations by placing the generator on a damper support (rubber disc or similar) and turn the rotor a fraction of a turn once a fortnight to avoid marking the bearing rings.

ALTERNATEURS PARTNER ALTERNATORS																																																										
<table style="width: 100%; border-collapse: collapse;"> <tr> <td>LSA <input style="width: 50px;" type="text"/></td> <td>Date <input style="width: 50px;" type="text"/></td> </tr> <tr> <td>N° <input style="width: 50px;" type="text"/></td> <td><input style="width: 50px;" type="text"/> Hz</td> </tr> <tr> <td>Min⁻¹/R.P.M. <input style="width: 50px;" type="text"/></td> <td>Protection <input style="width: 50px;" type="text"/></td> </tr> <tr> <td>Cos φ /P.F. <input style="width: 50px;" type="text"/></td> <td>Cl. ther. / Th. class <input style="width: 50px;" type="text"/></td> </tr> <tr> <td colspan="2">Régulateur/A.V.R. <input style="width: 100%;" type="text"/></td> </tr> <tr> <td>Altit. <input style="width: 50px;" type="text"/> m</td> <td>Masse / Weight <input style="width: 50px;" type="text"/></td> </tr> <tr> <td>Rlt AV/D.E bearing <input style="width: 50px;" type="text"/></td> <td></td> </tr> <tr> <td>Rlt AR/N.D.E bearing <input style="width: 50px;" type="text"/></td> <td></td> </tr> <tr> <td colspan="2">Graisse / Grease <input style="width: 100%;" type="text"/></td> </tr> <tr> <td colspan="2">Valeurs excit / Excit. values <input style="width: 100%;" type="text"/></td> </tr> <tr> <td colspan="2">en charge / full load <input style="width: 100%;" type="text"/></td> </tr> <tr> <td colspan="2">à vide / at no load <input style="width: 100%;" type="text"/></td> </tr> </table>	LSA <input style="width: 50px;" type="text"/>	Date <input style="width: 50px;" type="text"/>	N° <input style="width: 50px;" type="text"/>	<input style="width: 50px;" type="text"/> Hz	Min ⁻¹ /R.P.M. <input style="width: 50px;" type="text"/>	Protection <input style="width: 50px;" type="text"/>	Cos φ /P.F. <input style="width: 50px;" type="text"/>	Cl. ther. / Th. class <input style="width: 50px;" type="text"/>	Régulateur/A.V.R. <input style="width: 100%;" type="text"/>		Altit. <input style="width: 50px;" type="text"/> m	Masse / Weight <input style="width: 50px;" type="text"/>	Rlt AV/D.E bearing <input style="width: 50px;" type="text"/>		Rlt AR/N.D.E bearing <input style="width: 50px;" type="text"/>		Graisse / Grease <input style="width: 100%;" type="text"/>		Valeurs excit / Excit. values <input style="width: 100%;" type="text"/>		en charge / full load <input style="width: 100%;" type="text"/>		à vide / at no load <input style="width: 100%;" type="text"/>		<table style="width: 100%; border-collapse: collapse;"> <tr> <th colspan="3" style="text-align: center;">PUISSANCE / RATING</th> </tr> <tr> <td>Tension</td> <td><input style="width: 40px;" type="text"/></td> <td><input style="width: 40px;" type="text"/></td> </tr> <tr> <td>Voltage</td> <td><input style="width: 40px;" type="text"/></td> <td><input style="width: 40px;" type="text"/> V</td> </tr> <tr> <td></td> <td><input style="width: 40px;" type="text"/></td> <td><input style="width: 40px;" type="text"/> Ph.</td> </tr> <tr> <td>Connex.</td> <td><input style="width: 40px;" type="text"/></td> <td><input style="width: 40px;" type="text"/></td> </tr> <tr> <td>Continue</td> <td><input style="width: 40px;" type="text"/></td> <td><input style="width: 40px;" type="text"/> kVA</td> </tr> <tr> <td>Continuous</td> <td><input style="width: 40px;" type="text"/></td> <td><input style="width: 40px;" type="text"/> kW</td> </tr> <tr> <td>40°C</td> <td><input style="width: 40px;" type="text"/></td> <td><input style="width: 40px;" type="text"/> A</td> </tr> <tr> <td>Secours</td> <td><input style="width: 40px;" type="text"/></td> <td><input style="width: 40px;" type="text"/> kVA</td> </tr> <tr> <td>Std by</td> <td><input style="width: 40px;" type="text"/></td> <td><input style="width: 40px;" type="text"/> kW</td> </tr> <tr> <td>27°C</td> <td><input style="width: 40px;" type="text"/></td> <td><input style="width: 40px;" type="text"/> A</td> </tr> </table>	PUISSANCE / RATING			Tension	<input style="width: 40px;" type="text"/>	<input style="width: 40px;" type="text"/>	Voltage	<input style="width: 40px;" type="text"/>	<input style="width: 40px;" type="text"/> V		<input style="width: 40px;" type="text"/>	<input style="width: 40px;" type="text"/> Ph.	Connex.	<input style="width: 40px;" type="text"/>	<input style="width: 40px;" type="text"/>	Continue	<input style="width: 40px;" type="text"/>	<input style="width: 40px;" type="text"/> kVA	Continuous	<input style="width: 40px;" type="text"/>	<input style="width: 40px;" type="text"/> kW	40°C	<input style="width: 40px;" type="text"/>	<input style="width: 40px;" type="text"/> A	Secours	<input style="width: 40px;" type="text"/>	<input style="width: 40px;" type="text"/> kVA	Std by	<input style="width: 40px;" type="text"/>	<input style="width: 40px;" type="text"/> kW	27°C	<input style="width: 40px;" type="text"/>	<input style="width: 40px;" type="text"/> A
LSA <input style="width: 50px;" type="text"/>	Date <input style="width: 50px;" type="text"/>																																																									
N° <input style="width: 50px;" type="text"/>	<input style="width: 50px;" type="text"/> Hz																																																									
Min ⁻¹ /R.P.M. <input style="width: 50px;" type="text"/>	Protection <input style="width: 50px;" type="text"/>																																																									
Cos φ /P.F. <input style="width: 50px;" type="text"/>	Cl. ther. / Th. class <input style="width: 50px;" type="text"/>																																																									
Régulateur/A.V.R. <input style="width: 100%;" type="text"/>																																																										
Altit. <input style="width: 50px;" type="text"/> m	Masse / Weight <input style="width: 50px;" type="text"/>																																																									
Rlt AV/D.E bearing <input style="width: 50px;" type="text"/>																																																										
Rlt AR/N.D.E bearing <input style="width: 50px;" type="text"/>																																																										
Graisse / Grease <input style="width: 100%;" type="text"/>																																																										
Valeurs excit / Excit. values <input style="width: 100%;" type="text"/>																																																										
en charge / full load <input style="width: 100%;" type="text"/>																																																										
à vide / at no load <input style="width: 100%;" type="text"/>																																																										
PUISSANCE / RATING																																																										
Tension	<input style="width: 40px;" type="text"/>	<input style="width: 40px;" type="text"/>																																																								
Voltage	<input style="width: 40px;" type="text"/>	<input style="width: 40px;" type="text"/> V																																																								
	<input style="width: 40px;" type="text"/>	<input style="width: 40px;" type="text"/> Ph.																																																								
Connex.	<input style="width: 40px;" type="text"/>	<input style="width: 40px;" type="text"/>																																																								
Continue	<input style="width: 40px;" type="text"/>	<input style="width: 40px;" type="text"/> kVA																																																								
Continuous	<input style="width: 40px;" type="text"/>	<input style="width: 40px;" type="text"/> kW																																																								
40°C	<input style="width: 40px;" type="text"/>	<input style="width: 40px;" type="text"/> A																																																								
Secours	<input style="width: 40px;" type="text"/>	<input style="width: 40px;" type="text"/> kVA																																																								
Std by	<input style="width: 40px;" type="text"/>	<input style="width: 40px;" type="text"/> kW																																																								
27°C	<input style="width: 40px;" type="text"/>	<input style="width: 40px;" type="text"/> A																																																								
LR 0021 Conforme à C.E.I 34-1 (1994). According to I.E.C 34-1 (1994).																																																										

Made by Leroy Somer - 1 024 930/b

LSA 37 - 2 & 4 POLE - ACC ALTERNATORS

TECHNICAL CHARACTERISTICS

2 - TECHNICAL CHARACTERISTICS

2.1 - Electrical characteristics

The PARTNER LSA 37 alternator is a machine without sliprings, using auxiliary phase capacitor to provide the self excitation (ACC system).

Interference suppression conforms with standard EN 55011, group 1, class B.

2.1.1 - Options

- Stator temperature detection probes.
- Space heaters.

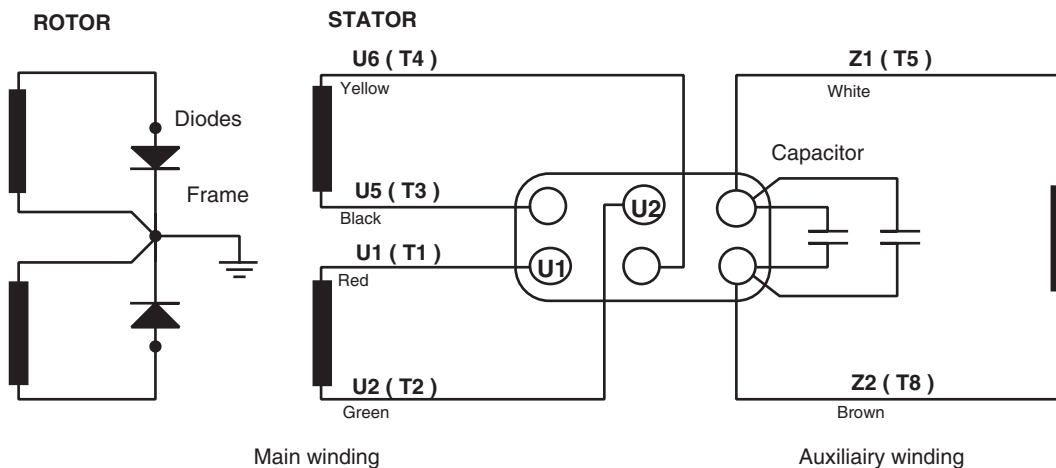

2.2 - Mechanical characteristics

- Steel frame
- End shields in aluminium
- Ball bearings greased for life
- Mounting arrangement

IM 1201 : (MD 35)

single bearing with standard feet and SAE flanges/coupling discs.

IM 1001 : (B 34)

two-bearing with SAE flange and standard cylindrical shaft extension.

- Drip-proof machine, self-cooled
- Degree of protection : IP 23

2.2.1 - Options

- Protection against harsh environments
- Air inlet filter, air outlet labyrinth seals.

LSA 37 - 2 & 4 POLE - ACC ALTERNATORS INSTALLATION

3 - INSTALLATION

3.1 - Assembly



All mechanical handling operations must be undertaken using approved equipment.

While being handled, the machine should remain horizontal.

3.1.1 - Handling

The generously-sized lifting rings are for handling the alternator alone. They must not be used to lift the genset. Choose a lifting system which respects the positioning of the rings.

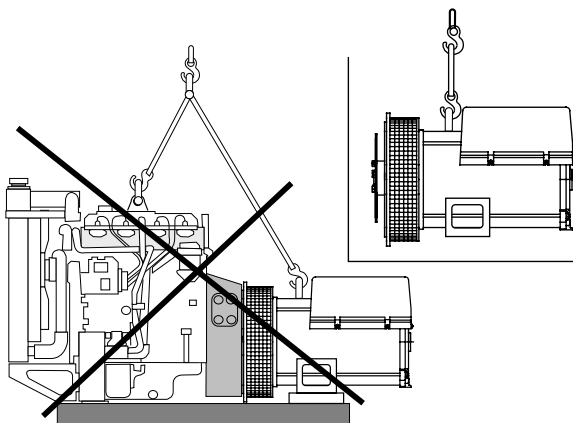

3.1.2 - Coupling

3.1.2.1 - single bearing alternator

Before coupling to the prime mover, check that both are compatible by:

- Undertaking a torsional analysis of the transmission.
- Checking the dimensions of the flywheel and its housing, the flange, coupling discs and offset.

ATTENTION

When coupling the alternator to the prime mover, the holes of the coupling discs should be aligned with the flywheel holes by cranking the engine.

Do not use the alternator fan to turn the rotor.

Tighten the coupling discs screws to the recommended torque (see section 4.6.2.) and check that there is lateral play on the crankshaft.

3.1.2.2 - two-bearing alternator

- Semi-flexible coupling

Careful alignment of the machines by measuring the concentricity and parallelism of the two parts of the coupling is recommended, the difference between the readings should not exceed the specified values (say 0,1 mm).

ATTENTION

This alternator has been balanced with a 1/2 key.

3.1.3 - Location

Ensure that the ambient temperature in the room where the alternator is placed cannot exceed 40°C for standard power ratings (for temperatures above 40°C, apply a derating coefficient). Fresh air, free from damp and dust, must be able to circulate freely around the air input louvres on the opposite side from the coupling. It is essential to prevent not only the recycling of hot air from the machine or engine, but also exhaust fumes.

3.2 - Inspection prior to first use

3.2.1 - Electrical checks



Under no circumstances should an alternator, new or otherwise, be operated if the isolation is less than 1 megohm for the stator and 100,000 ohms for the other windings.

There are two possible methods for restoring the above minimum values.

- a) Dry out the machine for 24 hours in a drying oven at a temperature of approximately 110 °C.
 - b) Blow hot air into the air input, having made sure that the machine is rotating with the exciter field disconnected.
- cNote: Prolonged standstill: In order to avoid these problems, we recommend the use of space heaters, as well as turning over the machine from time to time. Space heaters are only really effective if they are working continuously while the machine is stopped.

3.2.2 - Physical and visual checks

Before starting the machine for the first time, check that:

- the fixing bolts on the feet are tight
- the cooling air is drawn in freely
- the protective louvres and housing are correctly in place
- the standard direction of rotation is clockwise as seen from the shaft end (phase rotation in order 1 - 2 - 3). For anti-clockwise rotation, swap 2 and 3.
- the winding connection corresponds to the site operating voltage (see section § 3.3)

LSA 37 - 2 & 4 POLE - ACC ALTERNATORS INSTALLATION

3.3 - Terminal connection diagrams

To modify the connection, change the position of the terminal cables. The winding code is specified on the nameplate.



Any intervention on the alternator terminals during reconnection or checks should be performed with the machine stopped.

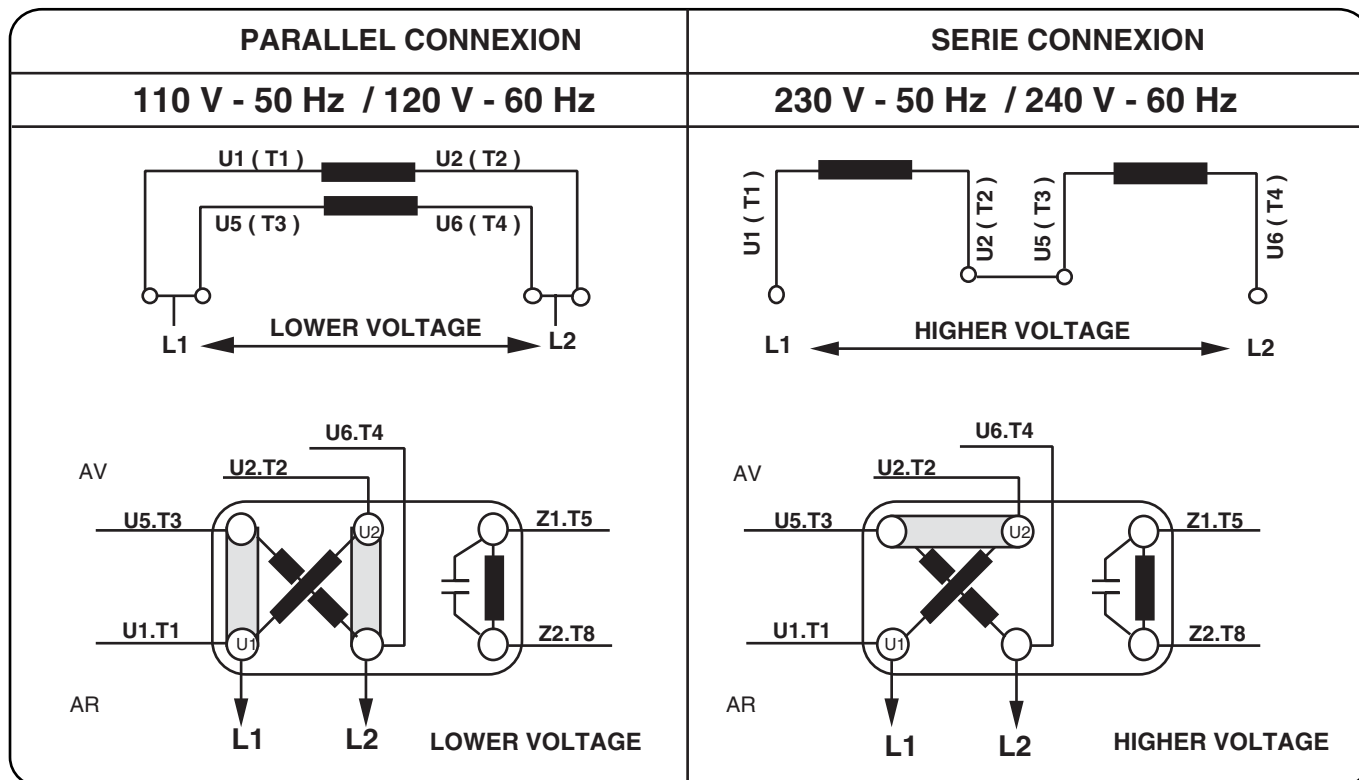

3.3.1 - Connection checks



Electrical installations must comply with the current legislation in force in the country of use.

Check that :

- the differential circuit-breaker conforms to legislation on protection of personnel, in force in the country of use, and has been correctly installed on the alternator power output as close as possible to the alternator. (Disconnect the blue wire of the R 791 interference suppression module linking the neutral).
- the machine should be connected with the terminal lugs on top of one another as shown in the terminal connection diagrams.

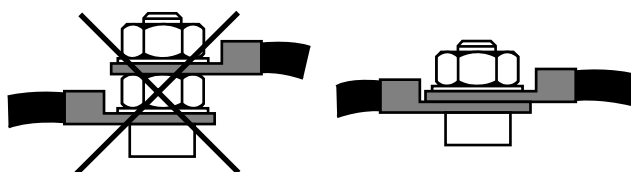

- any protective devices in place have not tripped,

- there is no short-circuit between phase or phase-neutral between the alternator output terminals and the generator set control cabinet (part of the circuit not protected by circuit-breakers or cubicle relays)

3.4 - Commissioning



The machine can only be started up and used if the installation is in accordance with the instructions and advice defined in this manual.

The machine is tested and set at the factory. When first used with no load, make sure that the drive speed is correct and stable (see the nameplate). On application of the load, the machine should maintain its rated speed and voltage; however, if the machine still operates incorrectly, the cause of the malfunction must be located (see section 4.4).

LSA 37 - 2 & 4 POLE - ACC ALTERNATORS

. SERVICING - MAINTENANCE

4 - . SERVICING - MAINTENANCE

4.1 - Safety measures



Servicing or troubleshooting must be carried out strictly in accordance with instructions so as to avoid the risk of accidents and to maintain the machine in its original state.



All such operations performed on the alternator should be undertaken by personnel trained in the commissioning, servicing and maintenance of electrical and mechanical components.

Before any intervention on the machine, ensure that it cannot be started by a manual or automatic system and that you have understood the operating principles of the system.

4.2 - Regular maintenance

4.2.1 - Checks after start-up

After approximately 20 hours of operation, check that all fixing screws on the machine are still tight, plus the general state of the machine and the various electrical connections in the installation.

4.2.2 - Cooling circuit

It is advisable to check that circulation of air is not reduced by partial blocking of the air intake and outlet grilles : mud, fibre, grease, etc.

4.2.3 - Bearings

The bearings are greased for life: approximate life of the grease (depending on use) = 20,000 hours or 3 years. Monitor the temperature rise in the bearings, which should not exceed 50°C above the ambient temperature. Should this value be exceeded, the machine must be stopped and checks carried out.

4.2.4 - Electrical servicing

Cleaning product for the windings

ATTENTION

Do not use : trichlorethylene, perchlorethylene, trichloroethane or any alkaline products.

Certain strictly defined pure volatile degreasing products can be used, such as :

- Normal petrol (without additives) ; inflammable
- Toluene (slightly toxic); inflammable
- Benzene (or benzine, toxic); inflammable
- Cyclohexane (non toxic); inflammable

Cleaning of the stator, rotor, exciter and diode bridge

The insulating components and the impregnation system are not at risk of damage from solvents (see the list of authorised products).

Avoid letting the cleaning product run into the slots. Apply the product with a brush, sponging frequently to avoid accumulation in the housing. Dry the winding with a dry cloth. Let any traces evaporate before reassembling the machine.

4.2.5 - Mechanical servicing

ATTENTION

Cleaning the machine using water or a high-pressure washer is strictly prohibited.

Any problems arising from such treatment are not covered by our warranty.

Degreasing : Use a brush and detergent (suitable for paintwork).

Dusting : Use an air gun.

If filters have been added to the machine after manufacture and do not have thermal protection, the service personnel should clean the air filters periodically and systematically, as often as necessary (every day in very dusty atmospheres).

Cleaning can be performed using water for dry dust or in a bath containing soap or detergent in the case of greasy dust. Petrol or chloroethylene can also be used.

After cleaning the alternator, it is essential to check the winding insulation (see sections 4.5.1).

4.3 - Fault detection

If, when commissioned, the alternator does not work normally, the source of the malfunction must be identified.

To do this, check that :

- the protective devices are fitted correctly
- the connections comply with diagrams in the manuals supplied with the machine
- the speed of the unit is correct (see section 1.3).

Repeat the operations defined in section 3.

LSA 37 - 2 & 4 POLE - ACC ALTERNATORS . SERVICING - MAINTENANCE

4.4- MECHANICAL FAULTS

Fault		Cause
Bearing	Excessive overheating of one or both bearings (bearing temperature 50°C above the ambient temperature) (With or without abnormal bearing noise)	- If the bearing has turned blue or if the grease has turned black, change the bearing. - Bearing not fully locked (abnormal play in the bearing cage) - End shields incorrectly aligned
Abnormal temperature	Excessive overheating of alternator frame (more than 40° C above the ambient temperature)	- Air flow (inlet-outlet) partially clogged or hot air is being recycled from the alternator or engine - Alternator operating at too high a voltage (> 105% of Un on load) - Alternator overloaded
Vibrations	Too much vibration	- Misalignment (coupling) - Defective mounting or play in coupling - Rotor balancing fault (Engine - Alternator)
	Excessive vibration and humming noise coming from the machine	- Phase imbalance - Stator short-circuit
Abnormal noise	Alternator damaged by a significant impact, followed by humming and vibration	- System short-circuit - Misparalleling Possible consequences - Broken or damaged coupling - Broken or bent shaft end - Shifting and short-circuit of main field - Fan fractured or coming loose on shaft - Irreparable damage to rotating diodes

4.5 - Electrical faults

Fault	Action	Effect	Check/Cause
No voltage at no load on start-up	Apply 6 v D.C. for 1 second on one of the capacitors	The alternator builds up and voltage is correct after battery removal	- Lack of residual magnetism - Check capacitor voltage. (correct value 10 to 15 v across auxiliary winding terminals, with capacitor(s) disconnected)
		The alternator builds up but voltage does not reach nominal value after battery removal	- Check if the circuit is broken in relation to either of the capacitors
		The alternator builds up but voltage collapses after battery removal	- Voltage too low : fault in rotation diodes
		No voltage output	- Auxiliary winding break - Rotating diodes burnt (check diodes) - Main field winding open circuit
Voltage too high	Reduce speed		Genset speed to high
Voltage correct on no- load, too low on load			- Too high speed drop on load - Check speed- Genset overload - Short circuit in main field, check resistance

4.5.1 - Measurement of resistance windings stator .



During this procedure, make sure that the alternator is disconnected from any external load.

- Unscrew the top cover
- Disconnect capacitors leads in order to read auxiliary winding resistance
- Disconnect leads from terminal plate in order to read main winding resistances.

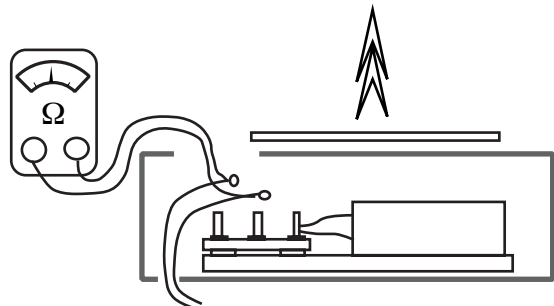

LSA 37 - 2 & 4 POLE - ACC ALTERNATORS

. SERVICING - MAINTENANCE

Resistance Ω Stator 2 P	Main winding		Auxiliary winding	
	50 Hz	60 Hz	50 Hz	60 Hz
	230 V	240V	110V	120V
LSA 37 M7	0,5	0,4	1,7	0,9
LSA 37 M8	0,3	0,3	1	0,6
LSA 37 L6	0,2	0,16	0,6	0,4
LSA 37 VL11	0,12	0,11	0,4	0,26

Resistance Ω Stator 4 P	Main winding		Auxiliary winding	
	50 Hz	60 Hz	50 Hz	60 Hz
	230 V	240V	110V	120V
LSA 37 M6	0,8	0,6	2,8	1,5
LSA 37 M7	0,4	0,3	1,4	0,7
LSA 37 L5	0,3	0,2	0,9	0,6
LSA 37 VL8	0,24	0,17	0,8	0,5

4.5.2 - Measurement of resistance windings rotor .



During this procedure, make sure that the alternator is disconnected from any external load.

- Unscrew the top cover
- Remove the N.D.E. bracket
- Unsolder diode leads in order to read resistances of each winding.

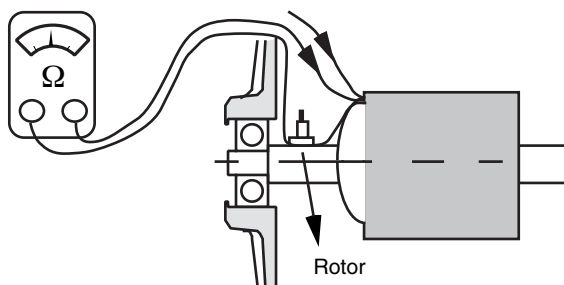

Resistance Ω Rotor 2 P	Main winding	Auxiliary winding
	LSA 37 M7	0,37
LSA 37 M8	0,4	0,6
LSA 37 L6	0,5	0,7
LSA 37 VL11	0,6	0,8

Resistance Ω Rotor 4 P	Main winding	Auxiliary winding
	LSA 37 M6	1,3
LSA 37 M7	1,6	1,6
LSA 37 L5	1,7	1,7
LSA 37 VL8	1,9	1,9

4.5.3 - Checking the diode bridge

- Proceed as for measuring of rotor resistances by unsoldering the leads from windings.
A diode in a good condition enables the current to flow in only one direction from anode to cathode.

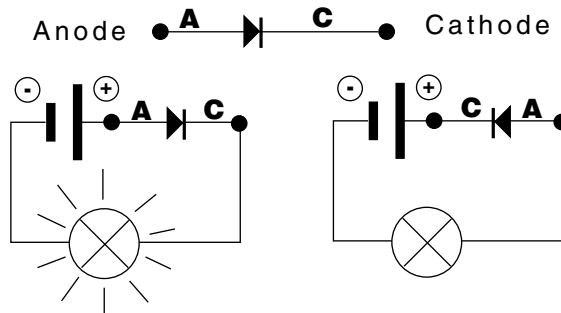

4.5.4 - Checking the capacitor



During this procedure, make sure that the alternator is disconnected from any external load.

- Unscrew top cover
- Disconnect capacitor (s) leads and connect capacitor (s) to a 220/240 V mains with a switch and a ammeter to read the current.

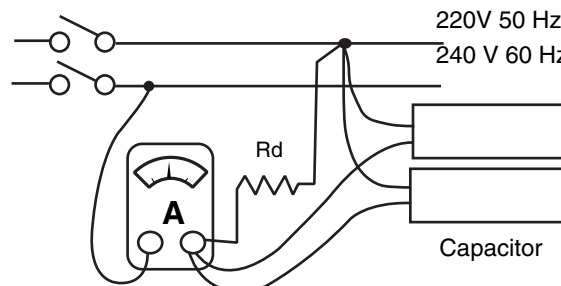

Rd : Discharge resistor (5000 Ω - 20 W)
Currents are given at ± 10%

Capacitor (...μF-450V - 3000H)				
	50 Hz	220V	60 Hz	240 V
2 Pole	μF	I (A)	μF	I (A)
LSA 37 M7	70	4,8	80	7,2
LSA 37 M8	100	6,9	120	10,8
LSA 37 L6	130	9	160	14,5
LSA 37 VL11	180	12,4	220	20

Capacitor (...μF-450V - 3000H)				
	50 Hz	220V	60 Hz	240 V
4 Pole	μF	I (A)	μF	I (A)
LSA 37 M6	50	3,4	70	6,3
LSA 37 M7	90	6	100	9
LSA 37 L5	120	8,2	130	12
LSA 37 VL8	130	8,9	200	13,5

LSA 37 - 2 & 4 POLE - ACC ALTERNATORS

. SERVICING - MAINTENANCE

4.6 - Dismantling, reassembly (see sections 5.3.1. , 5.3.2 & 5.3.3)



During the warranty period, this operation should only be carried out in an approved workshop or in our factory, otherwise the warranty may be invalidated.

ATTENTION

Whilst being handled, the machine should remain horizontal (rotor not locked when moved).

4.6.1 - Tools required

To fully dismantle the machine, we recommend using the tools listed below :

- 1 ratchet spanner + extension
- 1 torque wrench
- 1 flat spanner set
- 1 socket set
- 1 Allen key set
- 1 TORX bit set
- 1 puller .

4.6.2 - Screw tightening torque

IDENTIFICATION	screw Ø	Torque Nm
Diode nut	1/4 - 28 filets	3 N.m
Assembly rod	M 8	20 N.m
Earth screw	M 5	5 N.m
Balancing bolt	M 6 or M8	5 N.m
Discs/shaft screw	M 10	66 N.m
Lifting screw	M 8	4 N.m
Grille screw	M 6	5 N.m
Cover screw	M 6	5 N.m

4.6.3 - Access to diodes

- Unscrew the top cover
- Remove the N.D.E. bracket and access to diodes (110)

4.6.4 - Access to capacitor and connection

- Unscrew top cover fixing screws
- Remove terminal box lid (48)

4.6.5 - DISASSEMBLY

4.6.5.1 - N.D.E. bearing replacing on single bearing alternator

- Remove rotor (4) from stator (take care not to damage windings and diodes)
- Extract bearing (70) with a bearing puller

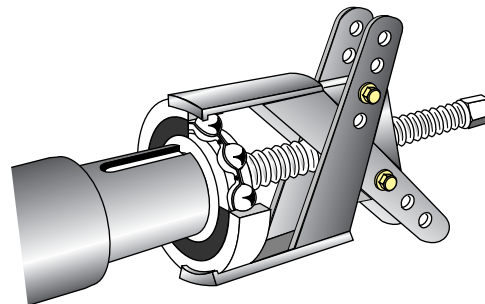

4.6.6 - Bearings replacing on two bearing alternator

- Un bolt D.E. bracket
- Pull out rotor + D.E. bracket (careful of damage to windings and diodes)
- Remove circlips (284)
- Remove from rotor (4) D.E. bearing set (410) + (60)
- Remove D.E. bearing (60)
- Remove N.D.E. bearing (70) with a bearing puller

4.6.7 - Complete disassembly

- Un bolt D.E. bracket (410) (only two bearings alternators)
- Pull out rotor + D.E. bracket (careful of damage to windings and diodes)
- Unscrew (49) and take off top cover (48)
- Disconnect connections
- Unscrew 4 nuts (38)
- Separate brackets (30) and (36) from stator (1)

4.6.8 - REASSEMBLY

Reverse procedure of disassembly.
(Check that the preloading wavy washer (79) is at the right place in the N.D.E. bracket).

ATTENTION

NOTE: If intervention is required on the main field (rewinding, replacement of components), the rotor assembly must be rebalanced.

LSA 37 - 2 & 4 POLE - ACC ALTERNATORS

. SERVICING - MAINTENANCE

4.6.9 - ASSEMBLY OF SINGLE BEARING SAE J 609 b

- 1 - Mount the flange on the engine. Recommended torque : 22 Nm.
- 2 - Mount the rotor on the engine shaft and fasten the tie rod (13). Recommended torque : 16 Nm.
- 3 - Mount the stator frame and fasten the 4 bolts to the flange. Recommended torque 9 Nm.
(Check that the preloading wavy washer (79) is at the right place in the N.D.E. bracket).

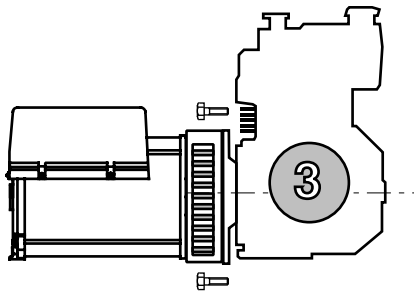
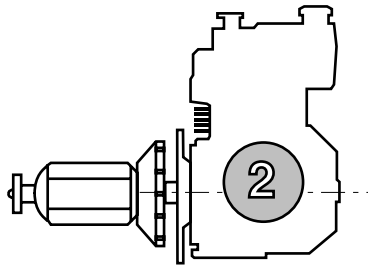
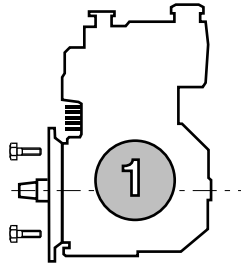

After coupling, turn the rotor by hand in order to detect a potential resistance and fit the top cover.

4.6.10 - DISASSEMBLY OF SINGLE BEARING SAE J 609 b

- 4 - UnscREW the 4 fixing bolts of the stator frame on the flange mounted on the engine.
Remove with care the stator frame.
- 5 - UnscREW the tie-rod from the drive-shaft. Using a hide mallet support the rotor in one hand and strike firmly on one of the pole faces to loosen from the engine shaft.
- 6 - UnscREW the 4 fixing screws of the flange from the engine.

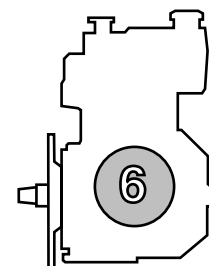
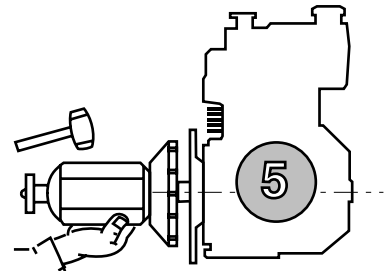
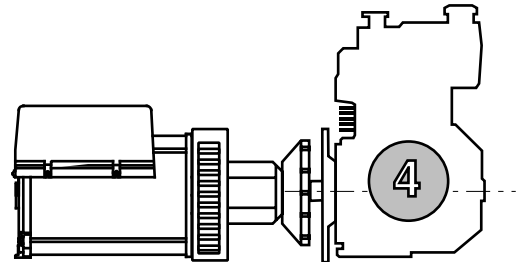

LSA 37 - 2 & 4 POLE - ACC

ALTERNATORS

SPARE PARTS

5 - SPARE PARTS

5.1 - First maintenance parts

Emergency repair kits are available as an option.
They contain the following items :

No.	Description	Qty	LSA 37	Coding
110	Diode	2	80A -700 V	ESC 070 DC 001
183	Capacitor	-	-	-

5.1.1 - Description of bearings

No.	Description	Qty	LSA 37	Coding
60	D.E. bearing	1	6208 2Z/C3	RLT 040 BH 020
70	N.D.E. bearing	1	6207 2Z/C3	RLT 035 BH 020

5.2 - Technical support service

Our technical support service will be happy to provide any information you require.

When ordering spare parts, you should indicate the complete machine type, its serial number and the information indicated on the nameplate.

Address your enquiry to your usual contact or :

MOTEURS LEROY-SOMER

Usine de Sillac/Alternators
16015 ANGOULEME CEDEX - FRANCE
Tel. : (33) 05.45.64.45.64
Technical support service :
(33) 05.45.64.43.66 - (33) 05.45.64.43.67
(33) 05.45.64.43.68 - (33) 05.45.64.43.69
fax : (33) 05.45.64.43.24
e. mail : sat.sil@leroysoyer.com

ATTENTION

**Part numbers should be identified from the exploded views and their description in the parts list.
Our extensive network of "service stations" can dispatch the necessary parts without delay.**

To ensure correct operation and the safety of our machines, we recommend the use of original manufacture spare parts.

In the event of failure to comply with this advice, the manufacturer cannot be held responsible for any damage.

5.3 - Exploded view, parts list

N°	Nbre	Description
1	1	Wound stator assembly
4	1	Wound rotor assembly
13	1	Pin
14	1	Nut
15	1	Fan
18	1	Balancing disc
21	1	Lifting eye
22	1	Key
30	1	D.E. bracket
33	1	Air exit screen
34	2	Bolts
36	1	N.D.E. bracket
37	4	Rods
38	4	Nut
48	1	Terminal box cover
49	6	Screws
53	1	Top
60	1	D.E. bearing
70	1	N.D.E. bearing
79	1	Wavy washer
110	2	Forward diode
124	1	Terminal plate
183	-	Capacitor
184	-	Fastener
185	-	Adhesive
188	1	Capacitor support
265	1	Coupling flange
266	4	Bolts
284	1	Circlip
322	1	Driving discs
323	6	Bolts
324	1	Lock washers
349	1	Rubber "O ring"
410	1	D.E.bearing housing
411	8	Bolts

LSA 37 - 2 & 4 POLE - ACC ALTERNATORS SPARE PARTS

5.3.1 - LSA 37 - Single bearing

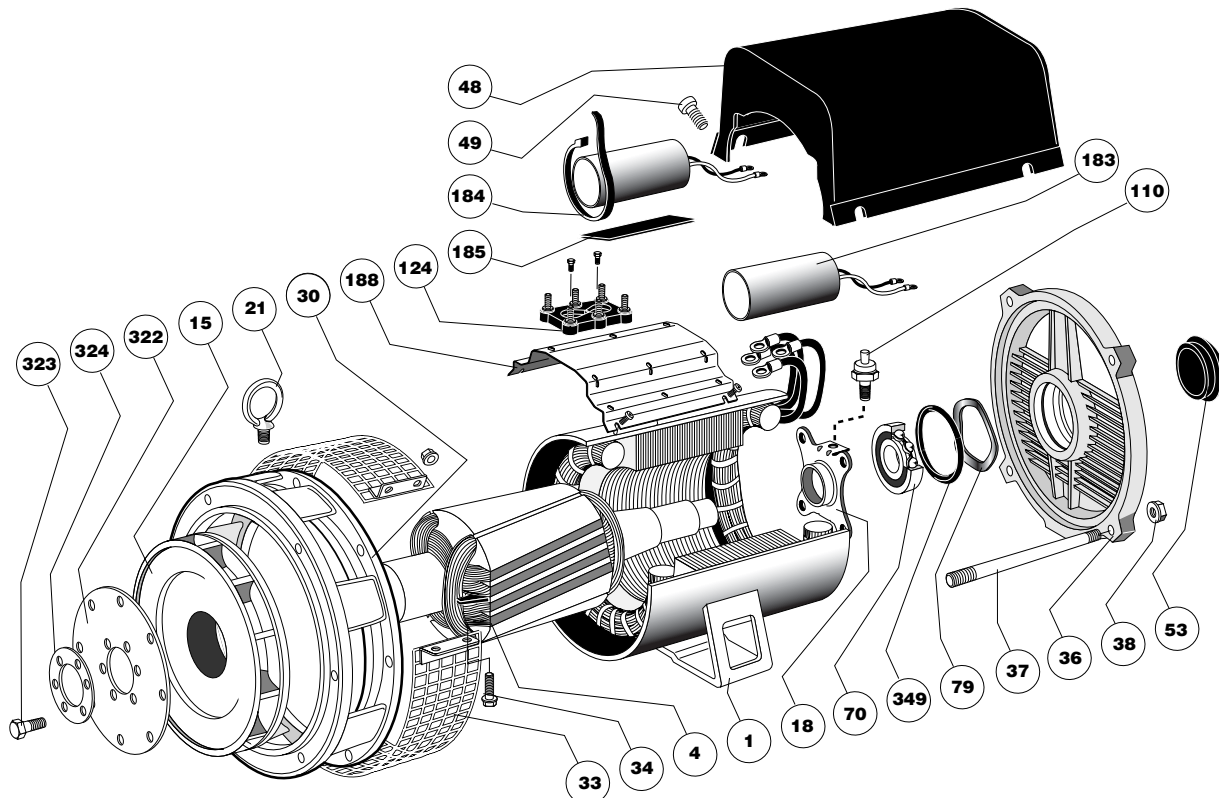

5.3.2 - LSA 37 - Two bearing

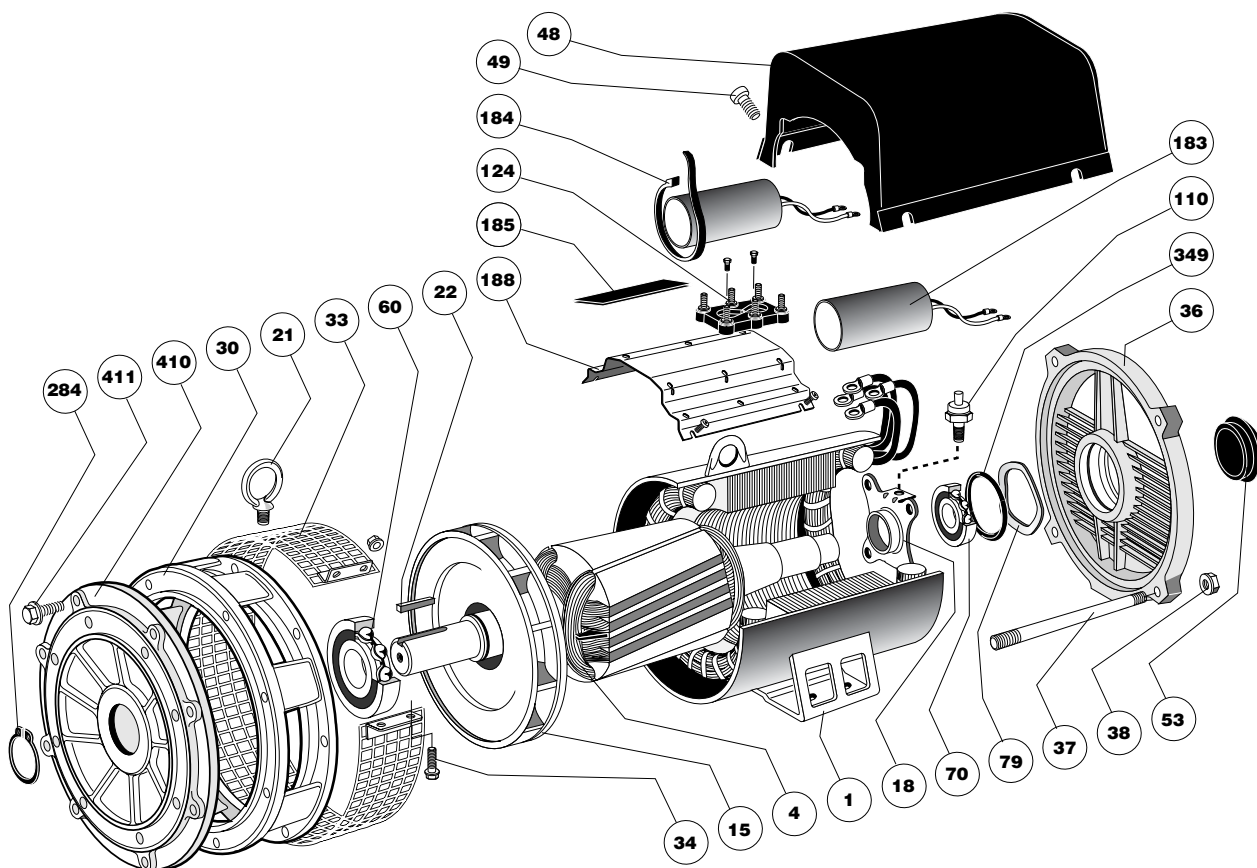

LSA 37 - 2 & 4 POLE - ACC

ALTERNATORS

SPARE PARTS

5.3.3 - LSA 37 - Single bearing SEAJ 609b

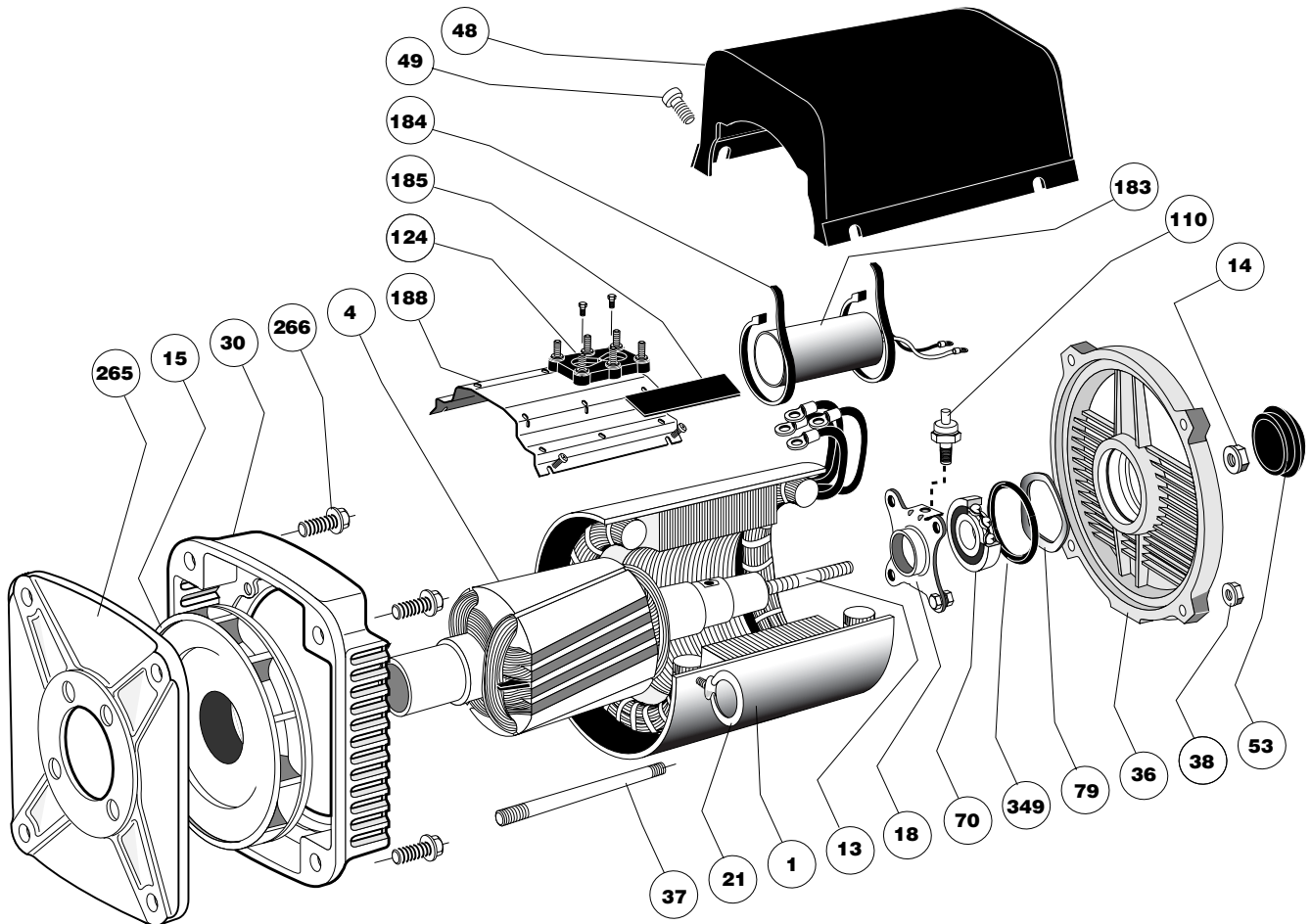

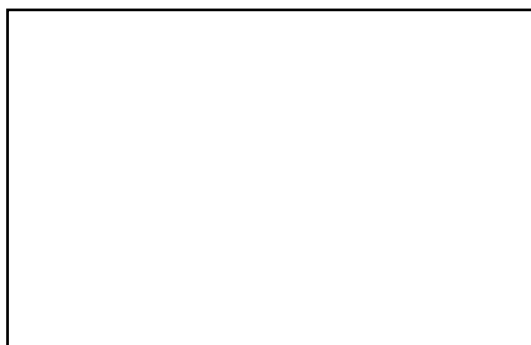

LEROY-SOMER 16015 ANGOULÊME CEDEX - FRANCE

RCS ANGOULÊME N° B 671 820 223
S.A. au capital de 62 779 000 €

www.leroy-somer.com