

DYNA[®]

PRO
SERIES

OWNERS MANUAL

DP4500/L
DP4500E/L
DP6000E/L

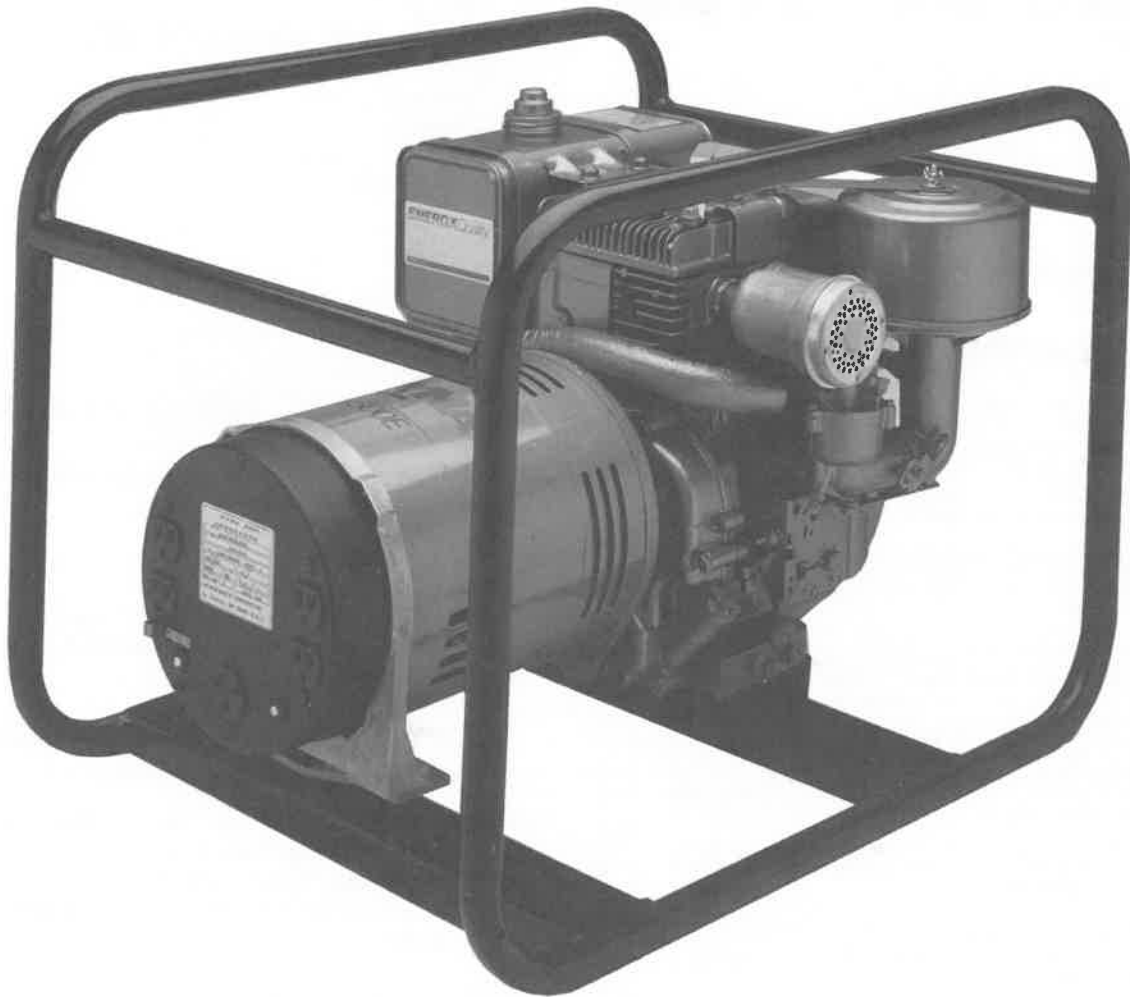

ENERGX
CORPORATION

225 South Cordova Avenue
Le Center, Minnesota 56057

READ AND UNDERSTAND ALL INSTRUCTIONS IN THE MANUAL BEFORE STARTING AND OPERATING THE GENERATOR SET.

USING THIS MANUAL

Congratulations on your choice of an ENERGX generator set. You have selected a high-quality, precision-engineered generator set designed and tested to give you years of satisfactory portable service.

To get the best performance from your new engine generator set, it is important that you carefully read and follow the operating instructions in this manual.

Should you experience a problem please follow the "Things To Check" near the end of this manual. The warranty listed in this manual describes what you can expect from ENERGX should you need service assistance in the future.

TABLE OF CONTENTS	PAGE
INTRODUCTION	i
ENERGX WARRANTY	i
GUIDE TO PRODUCT SAFETY	1
SPECIFICATIONS	2
Specification Table	2
Intended Uses	2
Restricted Uses	2
Unit Capabilities	2
PREPARATION INSTRUCTIONS	4
Unpacking	4
Unit Preparation	4
BASIC OPERATION	5
Initial Start Up	5
Starting	5
Starting Hints	5
Stopping And Storage	6
Operating Speed	6
Connecting The Load	6
INSTALLATION GUIDELINES	7
Wiring	7
OPERATOR CARE AND MAINTENANCE	8
Engine Care	8
Generator Care	9
Cleaning	9
Things To Check	10
Wiring Diagram	10

LIMITED WARRANTY

ENERGX Corporation warrants for one year from date of shipment that it will repair or replace at its option, for the original user, the whole or any part of the product found upon examination, by ENERGX at its factory at 225 South Cordova Avenue, Le Center, Minnesota, or by any factory-authorized service station, to be defective in material or workmanship under normal use and service.

For warranty service, return the product within one year from date of shipment, transportation charges prepaid, to the ENERGX factory or to your nearest factory-authorized service station.

There is no other express warranty. To the extent permitted by law, any and all warranties, including those of merchantability and fitness for a particular purpose, are limited to one year from date of shipment, and liability for incidental or consequential damages or expenses is excluded. Some states do not allow the exclusion or limitation of incidental or consequential damages, so the above limitation or exclusion may not apply to you. This warranty gives you specific legal rights; you may have other rights which vary from state to state.

ENERGX does not warrant engines or certain other component parts of the product since such items are warranted by the manufacturers.

ENERGX does not warrant alterations or repairs which were not made by the ENERGX factory or a factory-authorized service station and which affect the stability or reliability of the product.

ENERGX does not warrant products which have been exposed to misuse and/or negligence or have been involved in an accident.

ENERGX reserves the right to change or improve its products without incurring any obligations to make such changes or improvements on products purchased previously.

PROPER USE AND INSTALLATION

You must be sure your new engine generator set is:

- * Properly serviced before starting
- * Operated in a well ventilated area
- * Properly exhausted
- * Wired by a qualified electrician
- * Operated only for its designed purposes
- * Used only by operators who understand its operation
- * Properly maintained

COPY YOUR MODEL AND SERIAL NUMBER HERE

No other ENERGX generator has the same serial number as yours. It is important that you record the number and other vital information here, if you should ever need to contact us on this unit it will help us to respond to your needs faster.

MODEL _____

SERIAL NUMBER _____

DATE PURCHASED _____

DEALER _____

PRODUCT SAFETY

This engine generator set has been designed and manufactured to allow safe reliable performance. Improper or careless use can result in potential deadly hazards; from electrical shock, exhaust gas asphyxiation, or fire. Please read all safety instructions carefully before installation or use. Keep these instructions handy for future reference. Take special note and follow all warnings on the unit and in the manuals.

CAUTION: Possible Damage to Equipment.

CAUTION notes indicate any condition or practice, which if not strictly observed or remedied, could result in damage or destruction of the equipment.

WARNING: Personal Danger.

WARNING notes indicate any condition or practice, which if not strictly observed, that could result in personal injury or possible loss of life.

1. ELECTRIC SHOCK- The output voltage present in this equipment can cause a fatal electric shock. This equipment must be operated by a responsible person.

- A. Do not allow anyone to operate the generator without proper instruction.
- B. Guard against electric shock.
- C. Avoid contact with live terminals or receptacles.
- D. Do not operate this unit in rain or snow.
- E. Use only three-prong grounded receptacles and extension cords.
- F. Be sure the unit is properly grounded to an external ground rod driven into the earth.
- G. When servicing the generator discharge the large capacitor first.

2. FIRE HAZARD- Gasoline and other fuels always present a hazard of possible explosion and/or fire.

- A. Do not refuel when the engine is running or hot. Allow the engine to cool at least two minutes before refueling.
- B. Keep fuel containers out of reach of children.
- C. Do not smoke or use open flame near the generator set or fuel tank.
- D. Keep a fire extinguisher nearby and know its proper use. Fire extinguishers rated ABC by NFPA are appropriate.
- E. Store fuel only in an approved container, and only in a well-ventilated area.

3. DEADLY EXHAUST GAS - Exhaust fumes from any gasoline engine contain carbon monoxide, an invisible, odorless and deadly gas that must be mixed with fresh air.

- A. Operate only in well ventilated areas.
- B. Never operate indoors.
- C. Never operate the unit in such a way as to allow exhaust gases to seep back into closed rooms (i.e. through windows, walls or floors).

4. NOISE HAZARD - Excessive noise is not only tiring, but continual exposure can lead to loss of hearing.

- A. Use hearing protection equipment when working around this equipment for long periods of time.
- B. Keep your neighbors in mind when permanently installing this equipment.

5. CLEANLINESS - Keep the generator and surrounding area clean.

- A. Remove all grease, ice, snow or materials that create slippery conditions around the unit.
- B. Remove any rags or other material that could create potential fire hazards.
- C. Carefully wipe up any gas or oil spills before starting the unit.
- D. Never allow leaves or other flammable material to build up around the engine exhaust area.

6. SERVICING EQUIPMENT - All service, including the installation or replacement of service parts, should be performed only by a qualified technician.

- A. Use only factory approved repair parts.
- B. Do not work on this equipment when fatigued.
- C. Never remove the protective guards, cover, or receptacle panels while the engine is running.
- D. Use extreme caution when working on electrical components. High output voltages from this equipment can cause serious injury or death.
- E. When servicing this unit always avoid hot mufflers, exhaust manifolds, and engine parts. They all can cause severe burns instantly.
- F. Installing and wiring a home-standby generator is not a "do it yourself" project. Consult a qualified, licensed electrician or contractor. The installation must comply with all national, state, and local codes.

SPECIFICATIONS

MODEL	DP4500/L	DP4500E/L	DP6000E/L
Generator			
Surge Watts	4500	4500	6000
Continuous Watts	4000	4000	5500
Volts	120/240	120/240	120/240
AMPs @ 240 Volts	16.7	16.7	22.5
Receptacles			
NEMA 5-15 (120V)	4	4	4
NEMA 6-20 (240V)	1	1	1
Engine			
Size	8 HP	8 HP	11HP
Model	190412	190417	252417
Fuel Capacity	1 GAL	1 GAL	1 1/2 GAL
Fuel Consumption	.87g/hr	.87 g/hr	1.09g/hr
Starting System	Recoil	Recoil/Electric	
Muffler	Standard Low Tone		
Type	See Engine Shroud Above		
	Recoil For Type		
Stop System	Mechanical Ground		
Complete Unit			
Weight (dry)	157 LBS	157 LBS	185 LBS
Dimensions LxWxH	24x19x20	24x19x20	30x21x20
Owner Must Provide			
Fuel	Unleaded Gasoline		
Oil Type	10W-30 SF, SE, SD, SC		
	See engine manual for additional information.		
Oil Capacity	2 3/4 pints		3 pints
Battery Size	N/A	U1*	U1*
*Cranking Performance at 80 degree F. 190CCA			

INTENDED USES

1. These engine generator sets have been designed primarily for portable use. Receptacles are provided in the "end cover" of the generator for you to plug in your loads (portable appliance and tool). These units are dual wound generators, therefore the 120 Volt loads must be equally split with 1/2 of the rated capacity available on each of the two 120 Volt circuits. See unit capabilities for further explanation.

2. These units require large quantities of fresh air for cooling of both the engine and the generator. Fresh air is drawn from both the engine end and the generator end and is exhausted at the center of the unit. For safety, long life and adequate performance, these units should never be run in small compartments without positive fresh air flow.

RESTRICTED USES

1. DO NOT remove from the cradle assembly. Removal of the generator from the cradle assembly may cause excessive vibration and damage to the engine generator set.

2. DO NOT install and operate these portable generators in small compartment., i.e. generator compartment of vehicles, motor homes or travel trailers. These compartments will not allow enough free flow fresh air to reach the engine generator set for cooling and will allow the unit to overheat damaging both the engine and the generator. Small compartments will also develop hot spots where there is very little air flow and may cause a fire.

3. DO NOT attempt to operate this unit at 50 cycles. These units are designed and governed to operate at 60 Cycles only.

UNIT CAPABILITIES

1. **Generator Connections** - The diagram below represents a typical 4000 watt generator. Up to 2000 watts at 120 volts (16.7 Amps) can be taken from the generator at receptacle A and up to 2000 watts at 120 volts from receptacle B, or 4000 watts at 240 volt from receptacle C. MIXED COMBINATION of 120 and 240 volt loads up to 4000 watts are also possible. CAUTION MUST BE EXERCISED TO PREVENT OVERLOADING EITHER OF THE 120 VOLT CIRCUITS (A OR B). Check the appliance or tool nameplates for the current and voltage to insure compatibility. Remember that power taken from receptacle C reduces the power available at both A and B. Any remaining 120 volt loads should be equally divided between A and B. Failure to split the load will cause permanent damage to the stator. This type of damage constitutes abuse and will not be warranted.

The following currents (measured in amps) are produced at 120 & 240 volts for typical wattages shown.

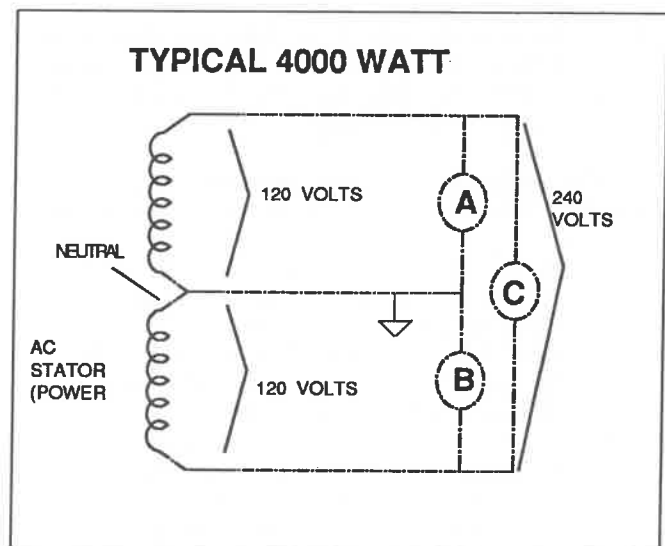

SPECIFICATIONS

AMPS AT 120 VOLT	120 VOLT 240 VOLTS		
	RECEPTACLE ID		
MODEL	A	B	C
DP4500/L	16.7	16.7	16.7
DP4500E/L	16.7	16.7	16.7
DP6000E/L	22.9	22.9	22.9

2. **Starting Electric Motors** - Electric motors require much more current (amps) to start them than to run them. Some motors, particularly low cost split-phase motors are very hard to start and require 5 to 7 times as much current to start them as to run them. Capacitor motors are easier to start and usually require 2 to 4 times as much current to start them as to run them. Repulsion Induction motors are the easiest to start and usually require 1 1/2 to 2 1/2 times as much to start them as to run them.

Most fractional horsepower motors take about the same amount of current to run them whether they are of Repulsion-Induction (RI), Capacitor (Cap), or Split-Phase (SP) type. The chart below shows the approximate current required to start and run various types of sizes of 120 volt 60 cycle electric motors under average load conditions.

HP	RUNNING STARTING AMPS			
	AMPS	SP	CAP	RI
1/6	3.2	16 TO 22	6 TO 13	5 TO 8
1/4	4.5	22 TO 32	9 TO 18	7 TO 12
1/3	5.2	26 TO 35	10 TO 21	8 TO 17
1/2	7.2	NOT MADE	14 TO 29	11 TO 18
1	13.0	NOT MADE	26 TO 52	20 TO 33

The figures given above are for average load such as a blower or fan. If the electric motor is connected to a hard starting load such as an air compressor, it will require more starting current. If it is connected to a light load, or no load such as a power saw, it will require less starting current. The exact requirement will also vary with the brand or design of the motor.

For 240 volt motors, the "running" current is half as much as shown for the 120 volt motors of the same size. Some dual voltage 120/240 volt motors are difficult to start on 240 volts when driven by engine/generators and can be started more easily when connected to operate on 120 volts. This is particularly true of "capacitor start-induction run" motors. Sometimes a 240 volt motor which cannot be started on the 240 volt circuit of a 120/240 volt generator can be started on a 120 volt circuit and then quickly switched to the 240 volt circuit after it is started. This can be done in applications where the motor is manually controlled and is started under "no load" conditions.

This brushless generator is designed to provide very high motor starting capability, limited primarily by the engine horsepower. The engine power is carefully matched to the generator full load rating.

If the starting load of the electric motor is beyond the capability of the generator set, the engine will be overloaded and slowdown. It will be unable to accelerate back to rated speed. The generator current will remain high and the circuit breaker may open, or the engine may stop.

In the event of a short circuit, the engine will be severely overloaded and the circuit breaker will open, or the engine will stop.

Because the heavy surge of current required for starting motors is required for only an instant, the generator will not be damaged if it can bring the motor up to speed in a few seconds of time. If difficulty is experienced in starting motors, turn all other electrical loads off and if possible reduce the load on the electric motor.

3. **Motor Starting Capacity** - listed below you will find the motor starting capability of your engine generator set.

Generator Model	Motor Size (code "G" capacitor start)
DP4500/L	1 1/2 HP
DP4500E/L	1 1/2 HP
DP6000E/L	2 1/1 HP

Trying to start a larger motor or higher code (ie. J or K) motor may result in damage to both the generator and the electric motor especially 120 volt motors.

PREPARATION INSTRUCTIONS

CAUTION: EQUIPMENT DAMAGE

THIS UNIT HAS BEEN SHIPPED WITHOUT OIL. Failure to maintain the engine oil at the proper level will result in serious engine damage.

UNPACKING

When you unpack your new ENGINE GENERATOR be sure to remove all the information sheets and manuals from the carton.

1. This power plant was in good order when shipped. Inspect the power plant promptly after receiving it. If damage is noted, notify the transportation company immediately; request proper procedures for filing a "concealed damage" claim. Title to the equipment and responsibility for filing claim rests with you when a generator is sent F.O.B. shipping point. Only you, can legally file a claim.
2. Before proceeding with the preparation of your new engine generator set for operation, take a couple of minutes to insure that the unit you have received is the correct model and review the specification pages in this manual to insure that this unit fits your job requirements.
3. After removing the engine generator from the carton locate and remove the shipping strap attached to the generator shock mount. See attached tag for removal instructions.

UNIT PREPARATION

Before your engine generator was shipped from our factory it was fully checked for performance. The generator was load tested to its full capacity, and the voltage and frequency were carefully checked and adjusted.

1. **Lubrication** - Before starting the engine, fill the crankcase to the proper level with a good quality oil. The recommended grade of oil and quantity of oil required is listed in both the engine operators manual and in the specifications section (pg 2) of this manual. The necessity of using the correct oil, and keeping the crankcase full cannot be overemphasized. Engine failures resulting from inadequate or improper lubricant are considered abuse and are not covered by Energx or the engine manufacturer's warranty.

2. **Gasoline Fuel** - When using gasoline always use a good grade of unleaded fuel. Leaded gasoline may be used if unleaded is not available. Gasoline containing alcohol, such as gasohol is not recommended. However if gasoline with alcohol is used,

it must not contain more than 10 percent Ethanol and must be removed from the engine during storage. DO NOT use gasoline containing methanol. Always insure that the fuel is clean and free of all impurities.

WARNING: FIRE DANGER

Gasoline and its fumes are VERY explosive when proper precautions are not taken.

Never use gasoline that has been stored for an extended period of time as the fuel will lose its volatile properties and you will be left with only the varnish residue. This varnish like substance will clog the carburetor and will not burn properly. The use of a fuel additive, such as STA-BIL, or an equivalent will minimize the formation of fuel gum deposits. If a unit has been out of operation for an extended period of time its best to drain old fuel from the engine and replace with fresh fuel before attempting to start.

DP4500E/L AND DP6000E/L ONLY

3. **Battery Installation** - All electric start engine generators sets are shipped with a battery kit for customer installation. This kit consists of a battery rack, battery tie down, battery cables, and instruction sheet for installation. After installing the battery rack, file the instruction sheet in the back of this manual for future reference.

If you intend to use the power plant's electric start system, you will need to purchase and install a battery to operate it. Units equipped with a recoils or rope start will operate satisfactorily without a battery. A twelve volt battery, group U1 rated at 190 CCA or larger is recommended for this electric start engine generator set. Follow the battery manufacturers recommendations for servicing and charging prior to use. Connect the battery to the electric start systems using the cables provided.

CAUTION: EQUIPMENT DAMAGE

These electric start engines are NEGATIVE GROUND. Use extreme caution when connecting the battery to connect the NEGATIVE battery terminal to GROUND.

For your safety always connect the positive battery cable to the "bat+" terminal first. Then connect the negative battery cable to the "bat-" terminal. Make sure all connections are clean and tight. Reverse the sequence when disconnecting, disconnect the negative cable first. These engines produce enough direct current to keep a battery charged under normal operating conditions, but were not intended to be used as a battery charger.

PREPARATION INSTRUCTIONS

WARNING: PERSONAL DANGER

Lead acid batteries produce explosive hydrogen gas when charging. Keep sparks, flames, and burning cigarettes away from the battery. Ventilate the area when charging or using the battery in an enclosed space. Lead acid batteries contain sulfuric acid, which causes severe burns. If acid contacts eyes, skin or clothing, flush well with water. For contact with eyes, get immediate medical attention.

BASIC OPERATION

INITIAL START UP

Use the following checklist to verify the correct preparation of the engine generator before starting.

On All Units Check:

1. Engine oil, fill as required with correct grade and quantity.
2. Fuel level, fill as required with clean fresh fuel.
3. Visually check unit for loose parts.

STARTING

The throttle control on these generators is preset and locked to operate at 3600 RPM (nominal) with no load speed set at 3690 RPM. Only a trained service technician should be allowed to adjust this speed setting. See "Operating Speed" section for additional information.

Electric Starting (DP4500E/L & DP6000E/L only) - If the engine is cold and stiff or if the battery is not fully charged, starting can be made easier by slowly hand cranking the engine through the compression stroke by fore pushing the starter button. This permits the starter to gain momentum before the heavy load of the compression stroke occurs, minimizing the drain on the battery and ensuring starting under such adverse conditions. Keep the battery fully charged, especially during cold weather operation.

1. Turn on the fuel supply.
2. Move the choke to the full on position. A warm engine will require less choking than a cold engine.
3. Depress the starter switch. The best starter life is provided by using short starting cycles of several seconds. Do not operate the starter more than 15 seconds each minute.
4. When the engine starts, open the choke gradually.
5. The engine should promptly come up to operating speed.

Generators, when installed for standby purposes, must be run periodically (at least once a month) for a minimum of 30 minutes to keep the battery charged. A trickle charger can also be used to keep the battery fully charged. The trickle charger should be a taper charger (usually 2 amps max). With a taper style charger, as the battery reaches its maximum charge capacity, the charger current tapers to near zero and maintains the battery in a fully charged condition. Manual type chargers with fixed or constant charging rates are not recommended, since the battery will be overcharged, permanently damaging the battery.

Manual starting - Refer to the engine manual for additional starting, operating, and stopping instructions.

1. Turn on the fuel supply.
2. Move the choke to the full on position. A warm engine will require less choking than a cold engine.
3. Grasp starter grip and pull slowly until starter engages, then pull cord rapidly to overcome compression, prevent kickback and start the engine. Repeat if necessary.
4. When the engine starts, open the choke gradually.
5. The engine should promptly come up to operating speed.

CAUTION: EQUIPMENT DAMAGE

Never permit the choke to remain on after the engine has run for a short time. It is not necessary to choke the engine when it is warm. Avoid over-choking.

STARTING HINTS

1. **Cold weather**
 - a. Be sure to use the proper oil for the temperature expected.
 - b. Use fresh winter grade fuel. Winter grade gasoline has higher volatility to improve starting. Do not use gasoline left over from summer.
 - c. A slightly richer fuel mixture will usually improve cold starting.
2. **Hot weather**
 - a. Be sure to use the proper oil for the temperature expected.
 - b. Use only summer blended gasoline. Using gasoline left over from winter may cause the unit to vapor lock, because of the higher volatility of the winter fuel.
 - c. DO NOT over choke the unit.

BASIC OPERATION

STOPPING AND STORAGE

1. Depress the stop switch.
2. Close the fuel shut-off valve. Always shut the fuel off whenever the engine is stopped to prevent fuel leakage from carburetor.
3. Before extended storage (over 30 days) certain precautions must be taken to ensure the fuel doesn't deteriorate and clog the fuel system. Note: The use of a fuel additive, such as STA-BIL, or an equivalent, will minimize the formation of gum deposits during storage. Such an additive may be added to gasoline in the engine's fuel tank or to gasoline in a storage container.
 - a. Remove the remaining fuel from the fuel tank.
 - b. Start the engine and allow it to run until all the fuel in the carburetor and the fuel lines has been used up and the engine stops.
 - c. While the engine is warm drain oil and refill with fresh oil.
 - d. Remove the spark plug, pour approximately 1/2 ounce (15 cc) of engine oil into the cylinder and crank slowly to distribute oil. Replace spark plug.
 - e. Clean dirt and chaff from cylinder, cylinder head fins, blower housing, rotating screen and muffler areas.
 - f. Store in a clean and dry area.

OPERATING SPEED

The engine-generator must be run at the correct speed in order to produce the proper electrical voltage and frequency.

CAUTION: EQUIPMENT DAMAGE

The output voltage should be checked to insure the generator is working properly prior to connecting a load to the generator. Failure to do so could result in damage to equipment plugged into the unit and possible injury to the individual.

1. All engines have a tendency to slow down when a load is applied. The governor on the engine is designed to hold the speed nearly constant. When the electrical load connected to the generator is increased, the engine is more heavily loaded, and as a result the speed drops slightly. This slight decrease in speed, together with the voltage drop within the generator itself, results in a slightly lower voltage when the generator is loaded to its full capacity than when running no load. The slight variation in speed also affects the frequency of the output current. This frequency variation has no appreciable effect in the operation of motors, lights and most appliances. However, electronic equip-

ment and clocks will be affected if correct RPM is not maintained.

See Load vs. Output chart.

Although individual units and models may vary slightly, the normal voltage and frequency of the engine-generators described in this book are approximately as follows, under varying loads:

LOAD vs. OUTPUT

Generator Load Applied*	Frequency Speed (Hz) (RPM)	Generator voltage	
		120V Recpt.	240V Recpt.
None	3690 61.5	125V	250V
Half	3600 60.0	120V	240V
Full	3510 58.5	115V	230V

*Portion of plant's rated output current.

2. The speed of the engine was carefully adjusted at the factory so that the generator produces the proper voltage and frequency. For normal usage, the speed setting should not be changed. If the generator is being run continuously on a very light load, it is often advisable to lower the operating speed slightly. Whenever making any speed adjustments check the unit with a voltmeter or tachometer and be sure the speed is neither too high or low.

Lower voltage may damage both the generator and any load connected to it. Running the engine at excessively high speeds results in high voltage, which may significantly shorten the life of appliances being used.

2. Output voltage should be checked periodically to ensure continued proper operation of the generating plant and appliances. If the generator is not equipped with a voltmeter, it can be checked with a portable meter. Frequency can be checked by using an electric clock with a sweep second hand. Timed against a wrist watch or a stop watch the clock should be correct within +/- 2 seconds.

CONNECTING THE LOADS

1. **Applying The Load** - Allow the engine to warm up for two or three minutes before applying any load. This will allow the engine to reach normal operating temperature and oil to circulate throughout the engine. A short warm-up time will permit the engine to work more efficiently when the load is applied and will reduce the wear in the engine, extending its life.

- A. Receptacles have been provided on the control panel to connect the loads to. The loads

BASIC OPERATION

should be applied gradually. If a large motor is being started or multiple motors are being started, they should be started individually and the largest should be started first.

CAUTION: EQUIPMENT OVERLOAD

Keep the generator load within the generator and receptacle nameplate rating. Overloading may cause damage to the generator and/or the loads

- B. Most electric tools and appliances will have the voltage and amperage requirements on their individual nameplates. When in doubt consult the manufacturer or a local electrician. The nameplate amperage rating for electric motors can be misleading. See Starting Electric Motors in Specification Section.
- C. These engine generator sets are inherently self regulating based on engine speed. The engine governor will automatically adjust itself to the load. No harm to the generator will result if it is run with no load connected.

- D. Proper utilization of the receptacles located on the control panel is necessary to prevent damage to either the receptacles or the generator. The generator is a limited source of electrical power, therefore pay special attention to the receptacle and generator ratings. The nameplate rating can be obtained through a combination of receptacles or a single receptacle as long as the receptacle amperage rating is not exceeded. Both the 120 and 240 volt receptacles can be utilized at the same time. See Specification Section for proper load separation.

- 2. **Grounding** - All units must be grounded. Drive a 3/4 or 1" copper pipe or rod into the ground close to the engine-generator set. The pipe must penetrate moist earth. Connect an approved ground clamp, to the pipe. Run a no. 10 Awg wire from clamp to the generator ground lug or the battery negative terminal. Do not connect to a water pipe or to a ground used by a radio system.

INSTALLATION GUIDELINES

The engine-generators covered in this manual were designed for portable use. The manufacturer does not recommend installing or operating this generator indoors. The unit should be stored in a warm dry location. During a power outage move the unit outdoors to a flat dry location such as a driveway or a sidewalk.

If your home wiring has not been modified and a manual transfer switch installed (Figure E-1) you will have to plug your appliances such as furnace blower, sump pump and other items to be powered directly into the generator receptacles.

Before beginning the wiring installation recheck the rating of the generator set. Be sure it can handle the intended load and is compatible with the entrance voltage, phase, and current ratings. These suggestions are not intended to constitute recommendations or guarantee of satisfaction or performance.

WIRING

Wiring this unit into a home or business electrical system is NOT A SIMPLE DO-IT-YOURSELF JOB. For your safety all wiring must be done by a qualified electrician and conform to the National Electric Code and comply with all state and local codes and regulations. Check with local authorities before proceeding.

WARNING: PERSONAL DANGER

A fully isolated, double pole double throw manual transfer switch must be installed any time a generator is being connected to an existing distribution system.

- 1. These engine generator sets are designed for portable use. Therefore the receptacles on the units are designed to have the 120 and 240 volt portable appliance and tools plugged directly into them. Please note that the 3 wire 240 volt receptacle(s) on these units are designed to provide only 240 volts as there is no neutral connection in the receptacle. Split service 120/240 volts requires a 4 wire receptacle be installed. Consult a service center or your dealer for installation.

To connect these units directly to an emergency distribution panel select one of the following methods:

- A. Wire the distribution panel directly to the generator output using a fine strand (flexible) motor lead wire. DO NOT by pass circuit breakers.
- B. Replace the 240 volt receptacle on the unit with a 120/240 four wire twist-lock receptacle. (Nema Spec L14-30R) The use of locking receptacles and locking plugs will

INSTALLATION GUIDELINES

prevent the plug from being accidentally removed by bumping or vibration, causing a voltage imbalance or interruption.

When installing the L14-30R receptacle in place of the current 240 volt receptacle the neutral wire will have to be routed to the 120 volt receptacle currently in the unit. The hot leads (G1 & G3) and the ground are already connected to the existing receptacle.

2. Connect generator to house wiring circuits only through a fully isolated manual transfer switch. The transfer switch prevents damage to the generator and other circuit components if main line power is restored while the generator is connected. Installing a transfer switch also permits the use of normal fusing. See Figure E-1 for typical wiring example.

3. Since most homes today are wired for at least 100 amps, when operating the generator to power the home a secondary emergency distribution panel must be installed. The circuits to be powered during the outage are moved to that panel. Keep in mind only a limited amount of amperage is available. Some breaks may still have to be shut off to prevent an overload on the generator on initial start up of the unit. See the Specification Section for the amperage on your generator.

CAUTION: EQUIPMENT DAMAGE

Failure to properly limit and balance the load applied to the generator will cause the generator to produce low voltage and may damage the engine generator set. It may also cause sever damage to the loads connected to the generator at that time. Improper loading of the generator set constitutes abuse and will not be covered by warranty.

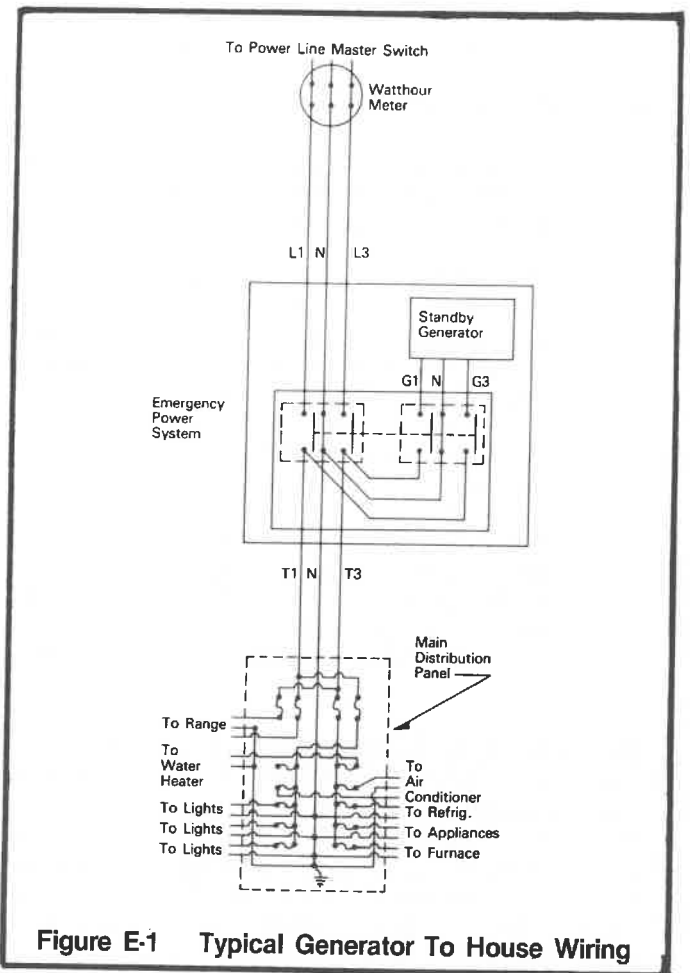

Figure E-1 Typical Generator To House Wiring

OPERATOR CARE AND MAINTENANCE

ENGINE CARE

If major engine service or repair is required contact an authorized engine service center. The manufacturer of these engines has established an excellent world-wide engine service organization. Engine service is very likely available from a nearby authorized dealer or distributor. Check the yellow pages of your local telephone directory under "Engines-Gasoline" for the closest engine repair center or ask the dealer from whom you purchased the power plant.

1. Change the oil after the first five hours of operation and every 50 hours thereafter under normal op-

erating conditions. Change engine oil every 25 hours of operation if the engine is operated under heavy load, or in high ambient temperatures.

- Remove oil drain plug at base of the engine and drain the oil with the engine warm.
- Replace oil drain plug.
- Remove oil filler plug and refill with new oil. Refer to the table in the engine manual for the proper grade of oil based on your operating temperature.
- Replace filler plug.

2. Checking the Oil Level: The oil level must always be checked before the engine is started. Take care

OPERATOR CARE AND MAINTENANCE

to remove any dirt or debris from around the oil fill plug before removing. Be sure the oil level is maintained. **FILL TO POINT OF OVERFLOWING** or on units with the extended oil fill to the "FULL" mark on the dipstick.

3. Servicing Air Cleaners

- A. **Cartridge Air Cleaner** - Remove and clean cartridge yearly or after every 25 hours, whichever occurs first. Service more often if necessary. Clean by tapping gently on flat surface. If very dirty, replace the cartridge using only original equipment parts available at any engine service center.

Do not use petroleum solvents, such as kerosene, to attempt to clean the cartridge. They may cause deterioration of the cartridge. **DO NOT OIL CARTRIDGE, DO NOT USE PRESSURIZED AIR TO CLEAN OR DRY CARTRIDGE.**

- B. **Dual Element Air Cleaner** - Clean and re-oil foam pre-cleaner at three month intervals or every 25 hours, whichever occurs first. Service more often under dusty conditions.

1. Remove knob and cover.
2. Remove foam pre-cleaner by sliding it off the paper cartridge.
3. Wash foam pre-cleaner in kerosene or liquid detergent and water
4. Wrap foam pre-cleaner in cloth and squeeze dry.
5. Saturate foam pre-cleaner in engine oil. Squeeze to remove excess oil.
6. Install foam pre-cleaner over paper cartridge. Reassemble cover and screw down tight.

Replace the cartridge included with Dual Element Air Cleaner yearly or every 100 hours. Service more often if necessary.

4. **Spark Plug** - Clean and reset gap at .030" every 100 hours of operation. Do not blast clean spark plug. Clean by scraping or wire brushing and washing with a commercial solvent. Poor spark will occur if terminal does not fit firmly on spark plug. If this happens reform the terminal to fit firmly on spark plug tip.

GENERATOR CARE

Proper care and maintenance of the generator is necessary to insure a long trouble free life.

1. **Exercising The Generator** - The generator should be operated every three to four weeks. It should be operated for a period of time sufficient to warm the unit up and to dry out any moisture that has accumulated in the windings. If left this moisture can cause corrosion in the winding. Frequent operation of the engine generator set will also insure that the set is operating properly should it be needed in an emergency.

2. **Generator Maintenance** - Any major generator service including the installation or replacement of parts should be performed only by a qualified electrical service man. **USE ONLY FACTORY APPROVED REPAIR PARTS.**

- A. **Bearing** - The bearing used in these generators is a heavy duty double sealed ball bearing. They require no maintenance or lubrication.

- B. **Receptacles** - Quality receptacles have been utilized. If a receptacle should become cracked or otherwise damaged, replace it. Using damaged or cracked receptacles can be dangerous both to the operator and to the equipment.

CLEANING

Remove dirt and debris with a cloth or brush. **DO NOT** use high pressure spray to clean either the engine or the generator. This high pressure spray could contaminate the fuel system and the generator components.

1. Keep the air inlet screen on both the engine and generator free of any dirt or debris to insure proper cooling. At least yearly remove the blower housing on the engine and clean the chaff and dirt out of the engine cooling fins and flywheel. Clean more often if necessary, failure to keep these areas clean may cause overheating and permanent damage to the unit.
2. Periodically clean muffler area to remove all grass, dirt and combustible debris to prevent a fire.
3. On engine mufflers equipped with spark arresters, the spark arrester must be removed every 50 hours for cleaning and inspection. Replace if damaged.

OPERATOR CARE AND MAINTENANCE

THINGS TO CHECK

Sometimes problems can be easily solved by checking a few basic things. Check below before you call or take your unit to a service center. It could save you time and money.

PROBLEM	POSSIBLE CAUSES
Won't Start	<ul style="list-style-type: none"> *Fouled spark plug. *Out of fuel. *Fuel turned off.
Voltage	<ul style="list-style-type: none"> *Engine speed is too low. *Generator overloaded. *Defective rectifier. *Defective stator. *Defective rotor.
Circuit Breaker Trips	<ul style="list-style-type: none"> * Defective load. * Defective receptacle.

PROBLEM	POSSIBLE CAUSES
Voltage too high	<ul style="list-style-type: none"> *Engine speed is too high.
Generator overheating	<ul style="list-style-type: none"> *Overloaded. *Insufficient ventilation.
No output voltage	<ul style="list-style-type: none"> *Short in load (disconnect). *No residual magnetism in generator. *Defective stator. *Defective rotor. *Shorted capacitor. *Shorted rectifier. *Defective receptacle.

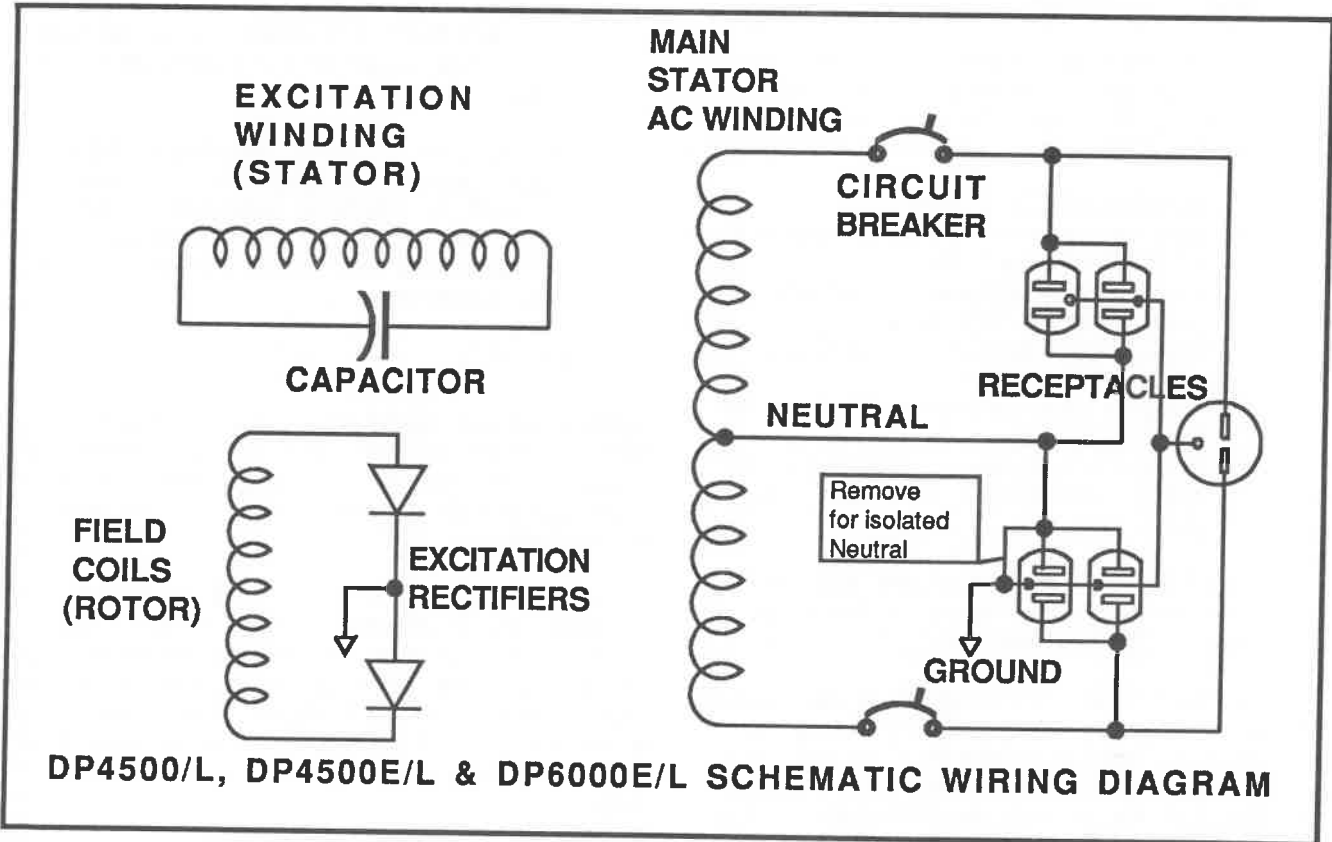

ENERGX
CORPORATION

225 South Cordova Avenue
Le Center, Minnesota 56057