

# INSTALLATION AND OPERATORS MANUAL

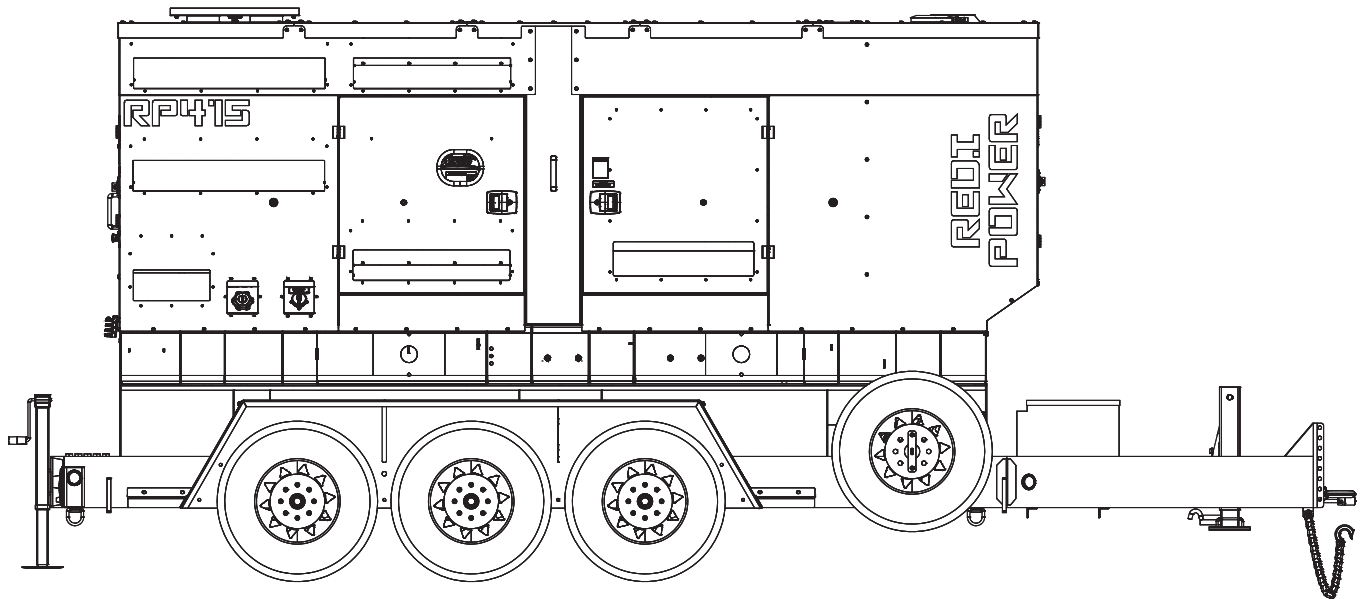

**COPY YOUR MODEL AND SERIAL NUMBER HERE**

No other WINCO generator has the same serial number as yours.

If you should ever need to contact us concerning this unit, it will help us to respond to your needs faster.

MODEL \_\_\_\_\_

SERIAL NUMBER \_\_\_\_\_

PURCHASE DATE \_\_\_\_\_

DEALER NAME \_\_\_\_\_

DEALER PHONE # \_\_\_\_\_



# TABLE OF CONTENTS

<b>SAFETY INFORMATION</b>	<b>4</b>	<b>WIRING DIAGRAMS</b>	<b>27</b>
SAFETY DEFINITIONS		THREE PHASE AC WIRE ZIG ZAG	
<b>SPECIFICATIONS</b>	<b>5</b>	THREE PHASE AC WIRE HIGH WYE	
RP415		<b>DSE 7310 MKII WIRING DIAGRAM</b>	<b>28</b>
<b>INTRODUCTION</b>	<b>6</b>	<b>ENGINE CODES</b>	<b>29</b>
TESTING POLICY		<b>CA EMISSION CONTROL STATEMENT</b>	<b>35</b>
PRODUCT DESCRIPTION		<b>REVALIDATION OF WARRANTY</b>	<b>36</b>
<b>PREPARING THE UNIT</b>	<b>7</b>	<b>US ENVIRONMENTAL STATEMENT</b>	<b>37</b>
START-UP CHECK LIST		<b>WARRANTY STATEMENT</b>	<b>38</b>
UNPACKING			
LIFTING THE GENERATOR SET			
TOWING THE EQUIPMENT			
BREAK-AWAY SYSTEM			
SETTING THE JACKS			
<b>INSTALLATION</b>	<b>8</b>		
GENERAL INFORMATION			
ENGINE GENERATOR SET MOUNTING			
VENTILATION REQUIREMENTS			
EXHAUST INSTALLATION			
FUEL INSTALLATION			
INSTALLING THE FUEL LINE			
INSTALLING THE BATTERY			
BATTERY CHARGER			
BLOCK HEATER			
MOUNTING THE AUTOMATIC TRANSFER SWITCH			
<b>AC CONNECTIONS</b>	<b>12</b>		
RECEPTACLE PANEL			
A.C. ELECTRICAL CONNECTIONS			
VOLTAGE SELECTOR SWITCH			
GROUNDING			
<b>DC CONNECTIONS</b>	<b>14</b>		
DC INTERCONNECTIONS TO THE ATS			
<b>STARTING PROCEDURE</b>	<b>16</b>		
SELECTING THE CORRECT VOLTAGE			
INITIAL START UP			
CONNECTING THE LOADS			
<b>DEF SYSTEM</b>	<b>18</b>		
<b>AVR WIRING</b>	<b>19</b>		
DSE A109			
<b>MAINTENANCE</b>	<b>20</b>		
CHANGING THE OIL			
CHANGING OIL FILTER			
CHANGE FUEL FILTER			
FILLING COOLANT			
CHANGING COOLANT			
CLEANING RADIATOR			
REPLACING BLOW-BY FILTER			
STORAGE			
DEF SYSTEM			
MAINTENANCE SCHEDULE			
<b>TROUBLESHOOTING TABLE</b>	<b>25</b>		
<b>WIRING SIZE TABLE</b>	<b>26</b>		
THREE PHASE AC WIRE LOW WYE			

## **SAVE THESE INSTRUCTIONS**

---

This manual contains important instructions that should be followed during installation and maintenance of the generator. Read and understand all instructions in the manual before starting and operating the generator.

### **USING THIS MANUAL**

Congratulations on your choice of a WINCO generator. You have selected a high-quality, precision-engineered generator designed and tested to give you years of satisfactory service.

To get the best performance from your new generator, it is important that you carefully read and follow the operating instructions in this manual.

Should you experience a problem please follow the "Troubleshooting Tables" near the end of this manual. The warranty listed in the manual describes what you can expect from WINCO should you need service assistance in the future.

# SAFETY INFORMATION

## IMPORTANT SAFETY INSTRUCTIONS

This engine generator set has been designed and manufactured to allow safe, reliable performance. Poor maintenance, improper or careless use can result in potentially deadly hazards; from electrical shock, exhaust gas asphyxiation, or fire. Please read all safety instructions carefully before installation or use. Keep these instructions handy for future reference. Take special note and follow all warnings on the unit labels and in the manuals.

### CALIFORNIA PROPOSITION 65



**WARNING:** This product contains crude oil, gasoline, diesel fuel and other petroleum products, Antifreeze to which can expose you to chemicals including toluene and benzene, Ethylene glycol (ingested) which are known to the State of California to cause cancer, birth defects or other reproductive harm and developmental issues. For more information go to [www.P65Warning.ca.gov](http://www.P65Warning.ca.gov).

## SAFETY DEFINITIONS

<b>DANGER</b>	Indicates an imminently hazardous situation which, if not avoided, will result in death or serious injury.
<b>WARNING</b>	Indicates a potentially hazardous situation which, if not avoided, could result in death or serious injury.
<b>CAUTION</b>	Indicates a potentially hazardous situation which, if not avoided, may result in minor or moderate injury. It may also be used to alert against unsafe practices.

### DANGER: ELECTRICAL SHOCK

The output voltage present in this equipment can cause fatal electric shock. This equipment must be operated by a responsible person.

- A. Do not allow anyone to operate the generator without proper instruction.
- B. Guard against electric shock.
- C. Avoid contact with live terminals or receptacles.
- D. Use extreme care if operating this unit in rain or snow.
- E. Use only three-pronged grounded receptacles and extension cords.
- F. Be sure the unit is properly grounded, installation must meet the national electrical code.

### DANGER: DEADLY EXHAUST GAS

Exhaust fumes from any gasoline engine contain carbon monoxide, an invisible, odorless and deadly gas that must be mixed with fresh air.

- A. Operate only in well ventilated areas.
- B. Never operate indoors including attached garages
- C. Never operate the unit in such a way as to allow exhaust gases to seep back into closed rooms (i.e. through windows, walls, floors).

### DANGER: FIRE HAZARD

Gasoline and other fuels present a hazard of possible explosion and/or fire.

- A. Do not refuel when the engine is running or hot.
- B. Keep fuel containers out of reach of children.
- C. Do not smoke or use open flame near the generator set or fuel tank.
- D. Keep a fire extinguisher nearby and know its proper use. Fire extinguishers rated ABC by NFPA are appropriate.
- E. Store fuel only in an approved container, and only in a well ventilated area.
- F. Follow local codes for closeness to combustible material.

### CAUTION: NOISE HAZARD

Excessive noise is not only tiring, but continual exposure can lead to loss of hearing.

- A. Use hearing protection when working around this equipment for long periods of time.
- B. Keep your neighbors in mind when using this equipment.

### CAUTION

Keep the generator and surrounding area clean.

- A. Remove all grease, ice, snow or materials that create slippery conditions around the unit.
- B. Remove any rags or other materials that could create a potential fire hazard.
- C. Carefully clean up any gas or oil spills before starting the unit.
- D. Do Not use the generator area as a storage closet.

### CAUTION

All service, including the installation or replacement of service parts, should be performed only by a qualified technician.

- A. Use only factory approved repair parts.
- B. Do not work on this equipment when fatigued.
- C. Never remove the protective guards, covers, or receptacle panels while the engine is running.
- D. Use extreme caution when working on electrical components. High output voltage from this equipment can cause serious injury or death.
- E. Always avoid hot mufflers, exhaust manifolds, and engine parts. They can cause severe burns instantly.
- F. The use of the engine-generator set must comply with all national, state, and local codes.

# SPECIFICATIONS

## RP415

### Standby

Wattage	370,000	370,000	370,000	370,000
kVa	462	462	462	462
Volts	120/208	120/240	277/480	346/600
Phase	Three	Three	Three	Three
PF	0.8	0.8	0.8	0.8
Amps	1,284	1,111	552	445
Hertz	60	60	60	60

### Prime

Wattage	333,000	333,000	333,000	333,000
kVa	416	416	416	416
Volts	120/208	120/240	277/480	346/600
Phase	Three	Three	Three	Three
PF	0.8	0.8	0.8	0.8
Amps	1,156	1,000	500	400
Hertz	60	60	60	60

### ENGINE

Make	FPT
Model	C13ENTZW69
Displacement	12.8L
Governor	Electronic

### ENGINE FLUID SPECIFICATIONS

Fuel	ASTM D-975 -1D or 2D EN590 or equivalent
Oil Type	SEE LUBRICATION SECTION
Oil Capacity	8.5 Gal
Cooling System	50/50 mix

See engine manual for additional information

### GENERATOR END

NOTE: Review the Stamford Newage nameplate on your generator. Some custom applications use other models. Check the generator nameplate for actual model number. Additional generator information available on line at [www.wincogen.com](http://www.wincogen.com) under Service Support.

Model	Stamford S411D-G
Winding Group	
208/240/480V	311
600V	17
Resistances:	
Rotor	1.44 Ohms @22°C
Stator (L-L)	0.00660 Ohms Per Ph @ 22°C
Exciter Rotor (L-L)	0.068 Ohms Per Ph @ 22°C
Exciter Stator (L-L)	18 Ohms @ 22°C
Voltage Regulator	MX321

# INTRODUCTION

## TESTING POLICY

Before any generator is shipped from the factory, it is fully checked for performance. The generator is loaded to its full capacity, and the voltage, current, and frequency are carefully checked.

Rated output of generator is based on engineering tests of typical units, and is subject to, and limited by, the temperature, altitude, fuel, and other conditions specified by the manufacturer of applicable engines.

This unit comes factory set for either key start or manual start. With the DSE 7310 MKII controller used in the manual start option it is possible to wire the control for remote start. Wiring instructions can be found further in this manual. The key start version does not have this option.

## PRODUCT DESCRIPTION

This engine-generator set is designed for unattended remote start operation. It can be operated as part of a fully automatic standby power system or independently as a local start unit in a prime power system. The engine-generator set is fully tested at the factory prior to shipment to insure proper operation of each individual component as well as the total system's performance and reliability.

The engine generator set consists of a multi-cylinder, liquid cooled engine nominally operating at 1800 rpm. The generator frequency regulation is maintained by the engine governor to within +/- .5 Hz or better with the electronic governor. The generator is a single bearing, direct drive, rotating field design. The generator is connected to the engine flywheel via flexible drive disks. The generator set is skid mounted with isolation mounts between the engine and base on all units.

The RP415 is a 24 volt system and requires two 12V batteries to complete the installation. Battery requirements are listed later under the battery installation section.

Unit Orientation Note: All references used in this manual for unit familiarization, access and component locations on the Generator Set are oriented from a TOP (plan) VIEW with engine at the FRONT and generator to the REAR.

WINCO uses a common junction box for all customer control and power connections (both AC output and DC control). The common electrical junction box is always on the left side at the generator end of the machine.

The engine is controlled and Generator Set operation is monitored for safe operation by a programmable microprocessor based electronic Engine Control Module (ECM) with an LCD digital display. The generator set ECM control is mounted on a vertical pedestal on the right side of the generator. The ECM is programmed with a cycle cranking sequence - 3 cycles of 15 seconds on/15 seconds off, and 5 minute cool-down delay. The cool-down delay can be changed in the field from 0 to 30 minutes by your installer. Other features, timing cycles, set points, and signal output capabilities are possible. Consult factory for procedure and passwords.

## NOTICE

**These units will automatically transfer if a power outage occurs while running in exercise mode.**

## GENERATOR SET

Every WINCO generator set has its own unique identity data plate. This data plate identifies the complete unit model number, the system serial number, and has links to the individual components that form the generator set in our factory records. Several of the major components also have their own individual data plates providing additional information to document build data for warranty and replacement parts.

## ENGINE

Refer to the engine operators manual for more detailed operation and maintenance information.

## CAUTION: EQUIPMENT DAMAGE

**Be sure to check the engine oil level frequently as specified in the engine manual.**

The engine manufacturer has established an excellent worldwide engine service organization; engine service is available from a nearby authorized dealer or distributor. Go to the WINCO website for a list of engine dealers or contact the WINCO Service Department.

The rated power of each engine-generator is limited by the temperature, altitude, and all other ambient conditions specified by the engine manufacturer.

## GENERATOR

WINCO generator sets use brushless, AVR (Auto-Voltage Regulator) controlled broad-range generator ends. The generator converts rotational mechanical energy into electrical energy. These WINCO units are equipped with generators manufactured by Cummins Generator Technology. Each generator 'end' has its own data tag. A unique serial number is on the data plate.

## TRAILER/HOUSING

These switchable voltage generators are normally shipped fully enclosed & mounted on a trailer. The trailer is DOT approved and you should receive a certificate of origin. This will allow you to register the equipment and obtain tags from your state. If you should encounter any problems registering the trailer, contact the WINCO Service Dept at 507-357-6831.

# PREPARING THE UNIT

## START-UP CHECK LIST

A Start-Up Completion & Warranty Validation Form was sent along with this manual. This must be completed and returned to WINCO Inc. within 180 days of the factory invoice date.

If this form is not returned, the Warranty may be voided.

## UNPACKING

1. As you receive your unit, it is critical to check it for any damage and annotate it on the BOL. If damage is noted, contact WINCO for assistance in getting the generator repaired.
2. Before proceeding with the preparations of your new generator for operation, take a couple of minutes to ensure the unit you have received is the correct model and review the specification pages in this manual to ensure that this unit meets your job requirements.

### CAUTION: EQUIPMENT DAMAGE

**This unit is shipped with oil and a 50/50 mix of coolant. Be sure to check all fluid levels before operating. See engine manufacturer's instruction manual for recommended oil requirements before initial starting.**

### Once generator set is on-site:

After inspecting the engine-generator for external, physical damage, locate and check the following items packed with the unit:

- a. Installation and Operator's Manual
- b. Engine manufacturer's instruction manual.
- c. Battery hold-down brackets & hardware.
- d. Unit components or accessory items shipped loose for on-site installation.
- e. Optional accessories.

## LIFTING THE GENERATOR SET

1. Make sure that the area under the equipment is kept clear.
2. Be certain rigging is designed to lift unit safely.
3. Never attempt to lift the unit unless you are certain the lifting device has sufficient capacity.
4. Never allow the unit to swing while suspended.
5. Be certain the supporting structure is adequate to handle the weight of the unit.

### CAUTION

**Only lift the unit using the four points on the generator base frame. The fuel tank and trailer lifting eyes should not be used for complete assemblies.**

### CAUTION

**Lifting a unit with diesel in the fuel tank will cause sloshing and unbalance the unit.**

## TOWING THE EQUIPMENT

### CAUTION

**Only transport by a towing vehicle with adequate GVWR rating.**

### WARNING: EQUIPMENT DAMAGE

**Never operate generator set during transportation.**

1. Always use a vehicle capable for safe operation.
2. Never tow without the safety chains secured. Always inspect safety chains, replace if damaged.
3. Always use the proper hitch size and type on the vehicle.
4. Never attempt to tow with a vehicle without side mirrors installed.
5. Verify all trailer lights function as intended.
6. Verify all lug nuts on the trailer are secured. Repeat this process after traveling 50 miles.

## BREAK-AWAY SYSTEM

A break-away system has been installed. Should the trailer become disconnected while driving, the break-away system will engage the electric breaks.

Always test the system before each outing by pushing the TEST button. There are three readings:

Full  
Low  
Charge

## SETTING THE JACKS

### WARNING

**Ensure the generator is properly secured on level ground. Failure to do so could cause the generator to suddenly roll away or move.**

1. Rotate the front jack from transport position to run position.
2. Level the unit using the jack before starting the unit.
4. Return jack to transport position before moving the unit.

# INSTALLATION

The max ambient temperature is 104°F. For derating information, see specification sheet. This unit should be installed in a well ventilated area, ensuring the exhaust air cannot be recirculated back into the engine.

## CAUTION

This unit will get hot while it is running and for some time afterward.

## WARNING: PERSONAL INJURY

Before proceeding with the installation, be sure the engine control is in the "stop" position and the emergency stop depressed. Also, be sure the generator MLCB (main line circuit breaker) is in the "off" position and the unit starting battery is disconnected

## GENERAL INFORMATION

This engine-generator set can be supplied as weather enclosed, trailered packages. The DOT certified trailer is available for mobile applications. Consult a qualified, licensed electrician or contractor to install and wire the gen-set. The installation must comply with all national, state, and local codes. The factory weather enclosures are acoustical housing intended for outdoor use only. Units are not intended to be used indoors and no support is available to assist in re-engineering finished packaged units.

Before beginning the installation process, recheck the voltage, phase, and amperage rating of the generator set. Be certain it can handle the intended load and are compatible with the intended loads. Plans for installation should be prepared with proper attention to mechanical and electrical engineering detail to assure a satisfactory system installation.

The information in this manual is offered only as a guide to finalizing your installation plans.

## NOTICE

For full service switching of the entire load, the ATS must be 'SE' (Service Entrance) rated or must have a properly rated fusible disconnect installed before the ATS to protect the contacts.

## ENGINE GENERATOR SET MOUNTING

The unit's main frame must be securely bolted to a solid base. The engine-generator is mounted on channels which are attached with special shock mounts to the main frame. This allows the engine-generator free movement without affecting the base or surrounding equipment.

## WARNING: EQUIPMENT DAMAGE

Never mount these engine-generator sets to a wooden base/structure. Over time, the wood will deteriorate and the unit mountings will come loose. These units must be mounted to a steel or concrete base.

The unit should be mounted to allow ample working room around it. A general rule to follow is to allow 24 inches or more of clearance for maintenance. Follow local codes for clearance from combustible surfaces.

## VENTILATION REQUIREMENTS

### OPEN SKID

## WARNING: EQUIPMENT DAMAGE

It is the installer's responsibility to ensure that there is sufficient cooling air available to prevent the engine and generator from over heating. Damage caused by overheating is not covered by warranty.

Providing proper air movement during your installation planning is essential. You will need to provide a fresh air inlet as well as a hot air outlet (to the outside of protection housing) for proper engine performance. These engine-generator sets are equipped with unit mount radiators and the engine is equipped with a pusher type fan. The hot air from the face of the radiator must be ducted out of the enclosure to ensure proper cooling. Failing to do so will allow the hot air to recirculate around the radiator causing the engine to overheat, resulting in an engine shutdown and damage. If louvers are used in front of the hot air duct to protect the unit from outside weather, the louvers should be 1½ times as large as the area of the radiator face to prevent back pressure.

Foam or other seals can be used to form a tight lip forcing all of the air from the engine fan out of the enclosure. In addition to a hot air discharge, you must plan a fresh air intake opposite the radiator discharge. Their fresh air inlets should be 1½ to 2 times larger than the radiator face. The extra air inlet area is required to minimize restriction and to provide combustion air for the engine. Do not block fresh air intakes with other equipment as this will result in insufficient air flow to the engine for cooling. Installing them opposite the hot air discharge will allow a sweeping flow of cooling air across the engine, preventing hot spots.

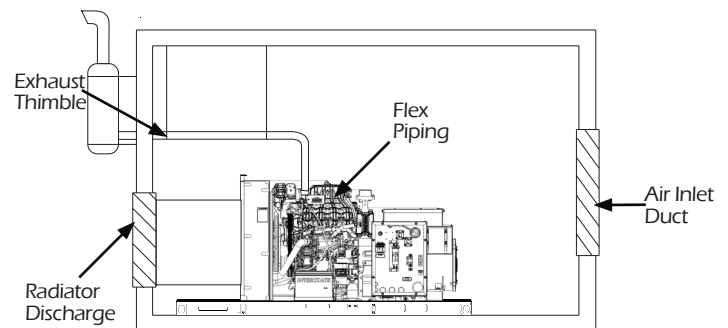

The WINCO installation manual OPM-112 contains additional information on indoor, open skid installations and is available electronically through our website or by requesting a copy from the factory.



## EXHAUST INSTALLATION

### WARNING: PERSONAL INJURY

Improper exhaust installation will allow dangerous gases to seep into enclosed spaces causing a hazard to your health and/or death.

All exhaust must be piped out of the enclosure. When selecting a location to exhaust fumes make sure that the potential for contact with people is controlled. Exhaust can enter buildings through windows, ventilation systems and other openings if proper precautions are not followed.

The exhaust must be isolated from the vibration of the engine. If the exhaust is connected in a rigid system it will result in damage to the engine. The generator comes equipped with an engine mounted flex pipe to aid your installation. Ensure proper alignment with the generator. The flex can be eliminated if it is pushed to one side to make a connection.

The most direct path possible should be used to get to the outside of the enclosure. Each bend restricts the pipe and increases back pressure. It may be necessary to increase the exhaust pipe diameter in some applications.

The exhaust pipe is very hot. When passing through the structure it is critical that a thimble or other appropriate technique is used to dissipate the heat and prevent the structure from catching on fire.

It is preferable to exhaust out the side of the enclosures. Slope the pipe slightly downward away from the engine to cause any water in the exhaust to run away from the engine. Do not exhaust near intake. Once outside the enclosure a rain cap or other technique must be used to keep water out of the exhaust. In mobile applications make sure the rain flap faces to the rear of the vehicle so that it is not blown open during transportation.

The generator ships with a critical grade muffler that should be installed to decrease noise. It can be mounted either internally or externally to the enclosure. The muffler cannot increase back pressure to more than 0.725 psi.

## FUEL INSTALLATION

The fuel supply should be as close as possible to the engine. This will reduce the installation cost of fuel runs. The information in this manual is offered to assist you in providing the proper fuel for your engine. However, this information is only provided to inform you of the engine's requirements and assist in making you aware of the decisions you must make. In no case should the instructions and information provided be interpreted to conflict with any local, state or national codes. If in doubt, always consult your local fire marshal, gas supplier or building inspector.

### WARNING: FIRE HAZARD

All fuel runs should be installed by a licensed fuel supplier.

In no case should the instructions or information provided be interpreted to conflict with any local, state, or national codes. If in doubt, always consult your local fire marshal or fuel supplier.

## INSTALLING THE FUEL LINE

### WARNING: FIRE DANGER

Connecting rigid fuel line (i.e. steel or copper line) directly to the inlet fuel filter or fuel pump may cause the fuel line to crack during operation creating a serious fire hazard.

The fuel supply should be as close to the engine as possible. This will reduce the installation cost of fuel runs and minimize line losses. The diesel fuel supply should be no more than 3 feet below the fuel inlet on the pump. If your fuel supply is lower than three feet you may have to install an additional lift pump to bring the fuel up to the mechanical fuel pump on the engine.

The information in this manual is offered to assist you in providing the proper fuel for your engine. However, this information is only provided to inform you of the engine's requirements and assist in making you aware of the decisions you must make. In no case should the instructions or information provided be interpreted to conflict with any local, state, or national codes. If in doubt, always consult your local fire marshal or fuel supplier.

Engine generator sets are properly adjusted before they leave the factory. Connecting a fuel supply with adequate supply volume is critical to reliable operation. Diesel units with optional base mounted fuel tanks are pre-plumbed to the mechanical fuel pump on the engine.

Open skid mounted diesel units are often supplied with capped inlet and return lines. The use of a sustainable customer supplied flexible fuel line is essential between the engine and fuel supply to provide a vibration break between your fuel supply and the engine.

## INSTALLING THE BATTERY

### CAUTION

In the following battery installation procedure, check to be sure the DSE 7310 MKII is in the "stop" position. This should be your last step before initial start-up.

The RP415 is a 24 volt system and requires two group 4D 12V batteries. The batteries should be rated at a minimum of 1050 CCA. Installation of the highest CCA rated battery, within the correct BCI group, will increase cold weather starting performance. Gel batteries should not be used with the battery tender installed in the generator enclosure.

Installation and servicing of batteries must only be performed or supervised by personnel knowledgeable of batteries and the required precautions. Keep unauthorized personnel away from batteries.

When installing or replacing batteries, use the proper group/size starting battery. The battery should be a maintenance-free lead acid design. Deep cycle batteries will not work for this application.

### CAUTION: PERSONAL DANGER

**NEVER** dispose a battery in a fire. The battery is capable of exploding.  
**DO NOT** open or mutilate the battery. Released electrolyte is known to be harmful to the skin and eyes and to be very toxic.  
These engine-generator sets are all **NEGATIVE** ground. Be very careful **not** to connect the battery in reverse polarity, as this may short circuit the battery charging system on the engine.

### CAUTION

A battery presents a risk of electrical shock and high short circuit current. The following precautions must be observed when working with batteries:

1. Remove watches, rings, and other metal objects.
2. Use tools with insulated handles.
3. Check both the battery cable ends and the battery posts to be sure they are free of corrosion.
4. Always connect the battery positive cable first and then connect the battery negative cable. When removing the battery cables from the battery, reverse the procedure, disconnect the negative first and then the positive cable.
5. Be sure all connections are tight and coat the terminals and cable ends with dielectric grease.

### WARNING

The electrolyte is diluted sulfuric acid that is harmful to the skin and eyes. It is electrically conductive and corrosive. The following precautions must always be taken.

1. Always wear full eye protection and protective clothing.
2. Where electrolyte contacts skin, wash off immediately with water.
3. If electrolyte contacts the eyes, flush thoroughly and immediately with water and seek immediate medical attention
4. Spilled electrolyte is to be washed down with an acid neutralizing agent. A common practice is to use a solution of one pound of bicarbonate of soda (baking soda) to one gallon of water. The bicarbonate of soda solution is to be added until the evidence of reaction (foaming) has ceased. The resulting liquid is to be flushed with water and the area dried.

### DANGER: EXPLOSIVE FIRE RISK

1. Never smoke when near batteries.
2. Do not cause a flame or spark in the battery area.
3. Always discharge static electricity from your body before touching batteries by first touching a ground metal surface.

## SERVICING BATTERIES

Batteries used on these units may, over time, lose water. This is especially true if you are using a trickle charger to maintain your battery. Different types of batteries

require various types of maintenance. Refer to the battery manufacturer for specific recommendations.

NOTE: Always make sure that a new battery is fully charged before installing it on a generator set. Failure to do so can cause damage to the engine control module in the generator set.

All connections must be clean and tight. Depending on your battery type, check the electrolyte in the battery periodically to be sure it is above the plates. Never allow the battery to remain in a discharged condition.

### CAUTION: EQUIPMENT DAMAGE

**Never attempt to jump start this engine. If the battery should accidentally become discharged, disconnect the battery cables and recharge the battery before attempting to start the unit. Boost/jump starting this unit improperly will result in PERMANENT DAMAGE TO THE ENGINE CONTROL MODULE (ECM).**

## BATTERY CHARGER

A 5 amp, SENS, electronic battery charger is provided standard on this unit. This charger has three rates of charging. During the first mode, known as Analyze Mode, the charging current is limited to 4 Amps at a voltage of up to 14/27 VDC. If there are any errors, it will trip a battery specific red fault LED, or if there aren't any errors, the red Charge LED will be solid red. Since, the battery system is 24V, the Precharge Mode, or Stage 2, will bypass to Stage 3. During Stage 3, known as the Constant Current Charge Mode, the charger holds the battery voltage at approximately 14/27 VDC. Stage 4, the Constant Voltage Conditioning Stage, each battery is being conditioned at 14V for up to three hours until the battery is fully charged. When complete, the charger will enter Stage 5, the Energy Saver Auto Maintain Mode. Each battery is being monitored while the charger is in standby mode, consuming little to no power until voltage drops below fully charged. The charger will turn on and auto maintain in a fully charged state.

## SOLAR CHARGER

The WINCO solar charger consists of two parts; the solar panel and the Sun Guard charge controller. The solar panel collects the energy while the Sun Guard controls the charging process acting as a switch to prevent the solar panel from discharging or overcharging the battery. If you are experiencing problems with your solar charging system contact WINCO service for trouble shooting instructions.

For best results, it is necessary to clean the solar panel surface from dirt and snow build up.

## BLOCK HEATER

The block heater on this unit is 2500 watts and should also be plugged in the Shore Power receptacle. The block heater is thermostatically controlled and when plugged in will maintain the engine coolant temperature between 100 and 120 degrees F.

## **MOUNTING THE AUTOMATIC TRANSFER SWITCH**

For standby applications, an automatic transfer switch (ATS) will be necessary for automatic starting. A wall mounted ASCO 300 ATS designed for inside or outside installation. The transfer switch is UL1008 approved. A seven day electronic exerciser circuit is installed in the ATS as standard equipment. The ATS also contains the power failure sensing circuitry necessary to start and stop the engine generator set. The transfer switch is also equipped standard with a 3 second start delay, and an adjustable 0 to 5 minute transfer delay to allow the engine to warm up before transferring the load to the generator. When the line power is restored the ATS has a 5 minute transfer delay to allow the incoming utility to stabilize before transferring back to line power and then an additional 5 minute engine cool down delay before the engine shuts down. Read and understand the ATS owners manual before installing, servicing or operating the transfer switch.

### **WARNING: FIRE HAZARD**

**All wiring must be done by a licensed electrician, and must conform to the National Electrical Code and comply with all the local codes and regulations. Check with the local authorities before proceeding.**

### **INSTALLATION NOTES**

Because of many different types of service, feeder and distribution equipment, no specific wiring instructions can be provided. It is recommended that only copper wire be used. In all cases it is essential that while the load is connected to the generator, there can be absolutely no feedback from the generator to the power line or the power line to the generator. When properly installed, the normal ATS Control and safety system will eliminate all paths and feedback.

To wire the automatic transfer switch into existing wiring, first determine which circuits will be on the emergency load circuit. If the entire load is transferred, the transfer switch can be wired directly after the watt-hour meter and the service entrance, providing the service entrance ampere rating is within the transfer switch's rated capability.

If only specific circuits are to be powered under emergency power failure conditions, an additional distribution panel designated "emergency distribution panel" must be installed.

All selected emergency circuits are removed from main distribution panels and installed in the emergency distribution panel. The ATS is then installed between the main panel and the emergency distribution panel. Suggested circuits: freezer, refrigerator, furnace, emergency lights, sump pump, emergency outlet circuits, etc. Total running load must not exceed generator rating.

# AC CONNECTIONS

## NOTICE: CLASS 1 WIRING METHODS ARE TO BE USED FOR ALL FIELD WIRING CONNECTIONS TO TERMINALS OF A CLASS 2 CIRCUIT

All wiring must be completed in accordance with the National Electric Code as well as any state and local codes.

You must pay particular attention to wire size requirement for the amperage of service you are dealing with. The table below provides you guidance on wire sizing based on both wire type and amperage. **Wire amperages have been derated for 40° C ambient temperatures operation.**

### WARNING

Make sure the generator is disconnected from the battery to prevent accidental starting.

## RECEPTACLE PANEL

(If equipped)

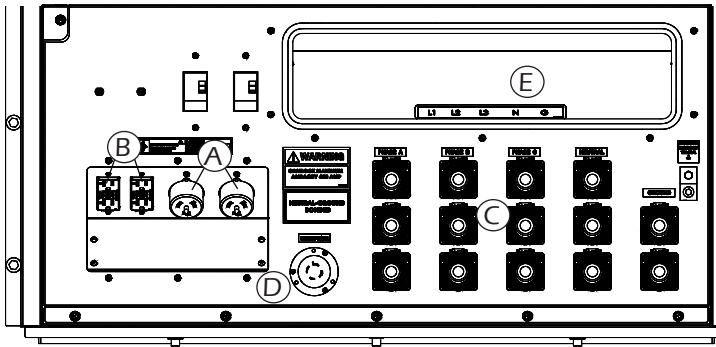

### WARNING: PERSONAL DANGER

Verify the main line circuit breaker and battery are disconnected before making connections. Failure could result in electrocution, which can result in serious injury or death.

#### 120/240 50A Circuit Breaker

These circuit breakers protect the 2 - 50 amp twistlock receptacles (A).

#### 120/240 20A

These two push button 20 amp circuit breakers protect the two GFCI receptacles (B).

#### A: 125/250 50A Receptacles

These receptacles are rated for dual voltage, 120 or 240V use. It is a 4-wire receptacle, with a center grounding pin. 4-wire drop cords plugged into this receptacle may be split into 120V receptacles at a distribution box. Each receptacle is protected by a two pole 50 amp circuit breaker mounted just above it. THIS RECEPTACLE UTILIZES A HUBBELL PLUG PART # CS6365.

#### B: 120/240 20A Receptacles

These duplex receptacles are protected by 20 amp circuit breakers mounted just above the duplexes. The "T" slot design both 15 and 20 amp 120V cords can be plugged in.

#### C: Camlock Connections

These Cam-Locks are connected to the full load terminal blocks and are capable of providing full generator output in all voltage configurations.

#### D: 125/250V 20 AMP 3-Wire Shore Power Plug:

NEMA Spec L14-20. This panel mounted plug is designed to plug directly in a standard 20 amp receptacle on an extension cord. The plug when connected will provide power to the block heater and the battery trickle charger mounted inside the generator enclosure. This can be used when the set is used in a standby application to keep the engine warm and the battery charged or in your rental yard to keep the battery charged up. This receptacle is to be powered by a GFCI circuit and installed in accordance with the United States National Electric Code.

#### E: Grommeted wire holes

These hole have been specifically provided for you to route your full power leads through to the output lugs. The routing holes were provided to insure that no small child or curious adult can reach inside and come into contact with the main output lugs with the unit running.

### WARNING

A mainline circuit breaker has been provided inside the generator housing. During all wiring installations, make sure the breaker is in the OFF position and the generator operating switch is in the OFF position.

## A.C. ELECTRICAL CONNECTIONS

### WARNING

Wiring and connections to unit should be performed by a competent technician. Improper installation could result in electrocution, which could cause equipment damage, serious injury or death.

Access for routing the wires into the terminal block is provided via the access door located in the back of the unit. The top panel will hinge open once unscrewed.

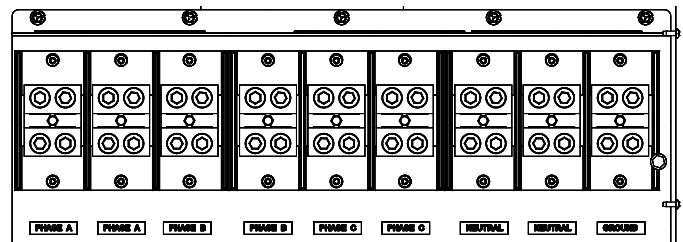

NOTE: The neutral is bonded to ground. This connection can be found in the circuit breaker panel.

#### NEUTRAL LUGS:

These lugs are bonded to ground and provided for you to connect your neutral wire from the transfer switch to the generator. Lugs will handle up to 500 MCM wire. Torque lugs to 150 in. lbs. using #4 wire and 375 in. lbs for 4 AWG.

#### GROUND LUG:

These ground lugs are bonded to neutral and are provided for you to connect your ground wire from the transfer switch to.

#### L2, & L3 POWER OUTPUT LUGS:

The full power terminal block is capable of handling full generator output at any of the selected voltages. In the 120/240V 3-Ph configuration with the wild leg (208 line to neutral) is wired to the L2 position.

Note: Lugs will handle up to two 350MCM 4 gauge wire. Torque lugs to 375 in. lbs.

## VOLTAGE SELECTOR SWITCH

(if equipped)

### WARNING: EQUIPMENT DAMAGE

**Never change the selector switch position while the engine is running.**

The selector switch is equipped with a lockable e-stop. This needs to be depressed when switching voltages. It is recommended that the e-stop has a pad lock installed to ensure the voltage is not switched while the engine is running.



The two positions are 120/208V 3PH and 277/480 3PH. For 120/240V 3ph, place the selector switch to the 120/208 3PH position and adjust the rheostat to 240V. By doing this you will get 240V, but your single phase voltage will be approximately 139V.

## GROUNDING

Proper grounding of your generator is application dependent. Carefully evaluate your planned use of your generator to understand which grounding you require. If you are not sure what to do, contact a competent professional to assist you. The NFPA 70 250:34-35 are good technical references.

### PERMANENTLY INSTALLED GENERATORS

This WINCO portable generator ships with a bonded neutral and overcurrent protection. NFPA 70 refers to this as a "separately derived system." When connecting it to a building a transfer switch specifically designed for GFCI and bonded neutral generators is required.

A competent technician can change the neutral configuration to match the application by following NEC wiring and ground labeling principles.

# DC CONNECTIONS

All DC connections are completed on the DIN rail blocks just behind the engine control. All DC connection must be separate conduit. You cannot mix AC and DC leads at the same conduit.

To install the wires, reference the following picture. Use a small flat head screwdriver to push the release spring inside the square hole (A). While the release is being pushed, insert the wire into the larger circular hole (B). Remove the screwdriver to secure the wire into place.

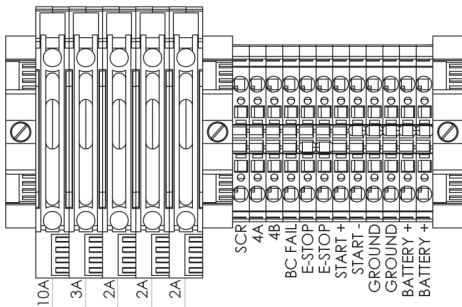
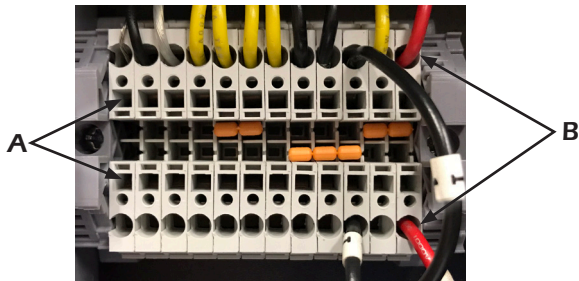

The E-Stop and Remote Start wires have been wired from the controller terminals to the panel for easy installation.

## REMOTE START

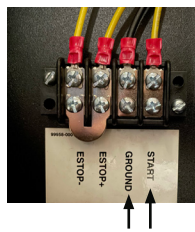

The two remote start leads from the Automatic Transfer Switch are connected to the two terminals marked GROUND & START. The WIRE in terminal GROUND is battery negative and the wire in the terminal labeled START is your remote start lead. Closing these two leads together will signal the DSE 7310 MKII to go into an autostart mode and start up the generator.

Depending on the distance, 14 to 16 gauge standard wire should be used. It is suggested that these wires be labeled S1 (ground) and S2 (start). The terminal blocks are designed to use terminal lugs on all wires and the screws should be torqued to 9.6 in. lbs.

Note: Any relay closure can be used to start and stop this generator. As long as the contact stays closed, the generator set will continue to run. Once the relay is opened, the unit will shut down and remain on standby mode until the remote start relay is closed again.

## E STOPS

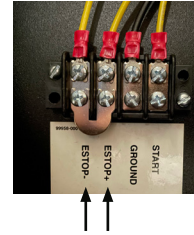

In some applications additional emergency stops may be desired or necessary. The controller has terminals designed allowing the addition of multiple remote emergency stops. E-stops must be normally closed to work properly in this system. The e-stop circuit supplies power to the fuel solenoid and the starter circuit. Opening any switch in the series prevents the engine from cranking or from receiving fuel to run.

To wire additional emergency stop switches first remove the orange jumper between the two Emergency Stop terminal blocks. Failure to remove the jumper will prevent the remote switches from working properly. Add wires through the terminal block to the new switch(es). The switches must be wired in series for proper function. Test each e-stop after wiring to ensure they function properly.

## SERIAL COMMUNICATION

DSE provides a series of remote accessories that can help provide useful information to operators. These accessories communicate over the DSE Net. Terminal blocks are wired to the distribution panel to aid in installation. Follow the instructions included with each accessory.

The generator controller can communicate with a variety of controls and monitoring systems, including RS232 and RS485. The ports are wired onto the back of the DSE7310. In order to finalize communication the program will need to be adjusted using the free DSE configuration software to enable the communication. Contact Winco service for a list of register values.

# DC INTERCONNECTIONS TO THE ATS

## WARNING

Use a properly installed transfer switches when isolating the generator set from utility power. Failure to do so could result in backfeeding, which is illegal and dangerous. Backfeeding causes serious injury or death.

## WARNING

Be sure Engine/Generator is in the OFF position before you make any DC interconnections.

## CAUTION

Never run the AC and DC wiring in the same conduit.

### ASCO 185 UL SWITCH

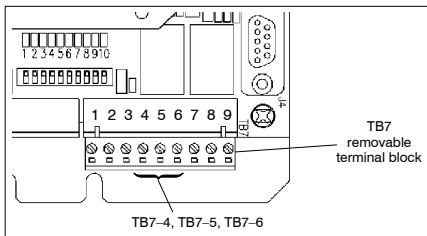

TB7 Generator starting contact terminals

Table A. Generator Start Connections

When the Utility fails	Terminals on Controller
contact closes	TB7-4 and TB7-5
contact opens	TB7-5 and TB7-6

### ASCO 300 UL SWITCH

When Normal Source Fails	Terminals On Transfer Switch
Contact Closes	TB1 and TB2
Contact Opens	TB1 and TB3

Engine start and auxiliary circuit terminal block TB located on 3ATS & 3NTS transfer switch.

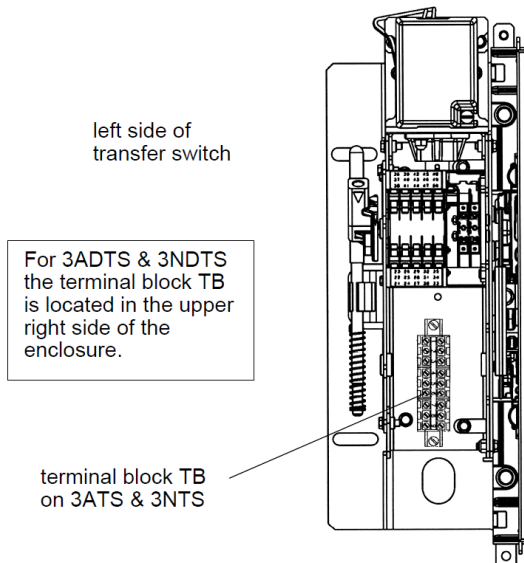

# STARTING PROCEDURE

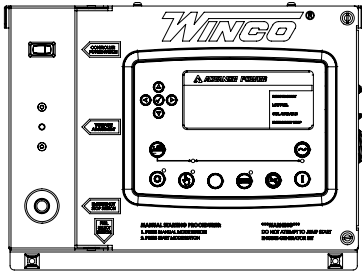

	<b>STOP/RESET</b> - This button places the module into its Stop/Reset mode. This will clear any alarm conditions for which the triggering criteria have been removed. The fuel supply de-energizes and the engine comes to a standstill. Should a remote start signal be present while operating in this mode, a remote start WILL NOT occur.
	<b>MANUAL MODE</b> - This button places the module into its Manual Mode. Once in Manual Mode, the model responds to the Start button to start the generator and run it off load.
	<b>START</b> - Pressing this button from STOP/RESET will start the engine and run the load.
	<b>AUTO MODE</b> - This button places the module into its Auto Mode. This mode allows the module to control the function of the generator automatically.
	<b>ALARM/LAMP TEST</b> - This button silences the audible alarm in the controller, de-activates the Audible Alarm output (if configured) and illuminates all of the LEDs on the module's face as a lamp test function.
	<b>MENU NAVIGATION</b> - Used for navigating the instrumentation, event log, and configuration screens.
	A small rocker switch is located on the underside of the engine control cabinet.  On gaseous models, the engine timing is controlled by the ECU on the engine and you need to tell it what fuel you want to operate on; LP or NG.  On diesel models, this switch has been disconnected and will do nothing.

## PROTECTIONS

When an alarm is present, the common alarm LED if configured will illuminate. The LCD display will show an icon to indicate the failure.

## WARNINGS

Warnings are non-critical alarm conditions and do not affect the operation of the generator system, they serve to draw the operator's attention to an undesirable condition. Warning alarms are self-resetting when the fault condition is removed. The icon will appear steady in the display.

## SHUTDOWN

Shutdowns are critical alarm conditions that stop the engine and draw the operator's attention to an undesirable condition. Shutdown alarms are latching. The fault must be removed and the STOP/RESET button pressed to reset the module. The icon will be flashing in the display.

## SELECTING THE CORRECT VOLTAGE

(if equipped)

A variety of phase voltages are available from the four position selector switch. The two basic connection patterns are Low (120/208) and High Wye (277/480)

When the 277/480V 3-PH positions are selected the AVR will automatically adjust the output to the nominal voltage. The voltage trim rheostat will be disabled. If you application requires a voltage different than nominal, installing the following jumpers will enable the rheostat in these positions.

277/480V 3-PH: Input E to ground

The 120/208V 3-PH position always has the rheostat active and will need to be trimmed at start up to meet desired nominal voltage.

The table below show the voltages at the terminal lug as well as the receptacles for all four voltage patterns available through the selector switch.

Voltage Selector Switch Position	Terminals	Minimum Voltage	Normal Voltage	Maximum Voltage
<b>120/208V THREE PHASE</b>				
LINE TO LINE	ALL	200	208	240
120/240V RECEPTACLES		110/200	120/208	139/240
LINE TO NEUTRAL	ALL	115	120	127
120V RECEPTACLES	ALL	115	120	127
<b>277/480V THREE PHASE</b>				
LINE TO LINE	ALL	460	480	480
120/240V RECEPTACLES		NONE	NONE	NONE
LINE TO NEUTRAL	ALL	240	277	277
120V RECEPTACLES		NONE	NONE	NONE

Before wiring and starting this unit, be sure you have the selector switch set for the right voltage. You must depress the safety switch below the selector switch to change the position of the voltage selector switch. If the unit is running, depressing this switch will shutdown the engine-generator set.

### WARNING: EQUIPMENT DAMAGE

Changing the voltage switch with the engine running may result in damage to the equipment.

This generator is equipped with a shunt trip circuit breaker that is interrupted by the DSE7310 controller if current limits are exceeded. These limits are adjusted based upon the nominal voltage of the current switch position.

## INITIAL START UP

### WARNING: EQUIPMENT DAMAGE

Before attempting to start this unit, complete your pre-start checklist and ensure the generator mainline circuit breaker is in the proper position



**prior to starting. Starting this unit without it properly connected can cause serious personal injury or equipment damage.**

DO NOT jump start these engine-generator sets. Starting these units on a low battery or jump starting them will cause damage to the engine control module.

Use the following check list to verify correct installation before starting the engine.

- Engine oil. Fill as required with proper grade/qty.
- Engine coolant. Fill as required with proper mixture.
- Unit mounting base properly bolted down.
- Clearance for service and maintenance on all sides.
- Proper fuel line material and size.
- All fuel line connections tight.
- Battery connections clean and tight
- Battery fully charged.
- All AC and DC wiring installed and properly protected.

After completing the previous checklist, the engine-generator set is ready for initial start-up.

## MANUAL MODE

1. Select the desired voltage with the selector switch.
2. Turn off the main line circuit breaker.
3. Press and release the MANUAL MODE button. The small LED light next to it should come on.
4. Press and release the green START ENGINE button. The DSE 7310 MKII will send a start signal to the glow plug solenoid on the engine. Preheating the engine for about 10 seconds at the end of that time will engage the fuel rack solenoid and the starter. This will start the cranking cycle (15 seconds on and 15 seconds off).

Note: There is no start delay in this mode of operation.

If the engine fails to start during this cranking period, the starter motor is disengaged and goes into a rest mode after which a second attempt is made to start the engine. Should this sequence continue through 3 cranking cycles the start sequence will be stopped and the display will show 'FAILED TO START'.

All engine functions are controlled by the DSE 7310 MKII controller. Once the unit is running, the control will display the engine information, To get the generator information, scroll down on the controller.

The AC output readings displayed on the DSE 7310 MKII are collected through the AC interface harness wired in the generator control box. Any shutdowns related to the AC output are a function of the controller are based on information collected in the DSE 7310 MKII via this AC harness.

5. After the engine is running at the proper speed, adjust the voltage to the desired level using the external voltage trim rheostat.

6. Turn on the proper main line breaker (either high or low

voltage) and padlock the lock bar to prevent the incorrect breaker from being turned on.

### WARNING: EQUIPMENT DAMAGE:

**Never apply a load to the generator until you have first checked the voltage at the terminal blocks or Cam-Locks.**

7. With the engine running smoothly check the no load voltage and frequency on the digital display. The voltage should be 208/240/480 AC depending on which model you have and a frequency of 59.5 to 60.5 hertz (Hz).

If you have the proper voltage at the generator the next step is to check the voltage at the generator terminals. The voltage between the L1, L2, and L3 terminals should be the same as it was on the generator front panel. The voltage should also be checked between the hot terminals (L1, L2, and L3) and the N to be certain of a balanced voltage output and a solid neutral connection.

ON 240 VOLT (DELTA) SYSTEMS BE SURE YOU KNOW WHERE THE HIGH VOLTAGE "WILD" LEG IS. IT MUST BE IN THE SAME LOCATION ON THE LINE SIDE AS IT IS ON THE GENERATOR SIDE.

### NOTICE

**If for any reason during the check out procedure the voltage and frequency are not correct, depress the STOP/RESET button and correct the trouble before proceeding.**

8. Stopping - In manual mode, pressing the STOP/RESET button will stop the unit but only after the cool down timers have timed out and there is no remote start signal being sent to the unit. Pressing the STOP/RESET button a second time will shut down immediately.

In the event of an emergency, the E-Stop can be pushed.

### WARNING: EQUIPMENT DAMAGE

**Stopping the generator without sufficient cool-down time, can result in premature wear and cause damage to engine components. The EStop and override shutdowns should only be used in the event of an emergency.**

## AUTO MODE

To activate the automatic start mode you will just need to depress the AUTO button, the LED indicator beside the button confirms that the unit is in automatic mode.

To test the Automatic Transfer Switch, follow the instruction on the operator's manual that came with the transfer switch. If you get a fault during the initial start up or prior to start up, it is most likely a false warning light. Simply reset the ATS start over.

Once you have completed testing of the ATS, be sure you ALWAYS leave the system in the standby mode, unless servicing the unit. For standby operation, press the AUTO button on the front of the control. The green light should light up next to the AUTO button.

NOTE: For setting the exerciser circuit, for all ATS, see the operator's manual shipped with the ATS.

## CONNECTING THE LOADS

### WARNING:

All wiring must be done in accordance with National Electric Code NFPA 70.

There are three ways the loads may be connected to the generator set:

- 1. Receptacle Panel -**  
A variety of receptacles have been provided for your convenience. The 120V receptacles are powered when the voltage selector switch is in the 120/240 single phase, and 120/208V three phase position. The 240V receptacles are only usable in the 120/240V single phase. In the 120/208V position, the 240V receptacles have only 208V at them. Refer to the voltage output table, located previously in this manual.
- 2. Full Power Load Connection Terminal Block -**  
For remote connections and connecting load distribution boxes, heavy duty terminal blocks have been provided. These terminal blocks are located on the rear of the unit. The neutral and ground are connected together at this panel. For use with an isolated neutral, remove the jumper strap between the neutral connection block and the ground lug. This will isolate the neutral from the ground and allow your a single point grounding at a distribution panel. When using these terminal blocks, be sure to use wire rated large enough to carry your full load or the full rated load of the generator.
- 3. Full Power Cam-Lock Connections -**  
For ease of connecting and disconnecting loads, these units have been equipped with Cam-Locks located behind the right hand, rear door. See the Cam-Lock Connections in this manual. Instructions for the Full Power load Connection Terminal Block apply for the Cam-Locks. If you need to run an isolated neutral system, the jumper between the neutral and ground must be removed at the terminal block.

## DEF SYSTEM

This generator set is equipped with a patented HI-eSCR (selective catalyst reduction) that allows a transformation of NOx into Nitrogen (N<sub>2</sub>) and water (H<sub>2</sub>O) by injecting Urea in the exhaust pipe. This process exhausts clean, breathable air.

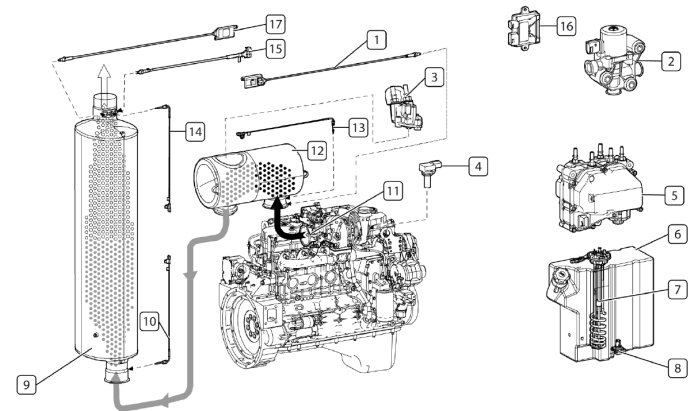

1. NOx sensor upstream of DOC
2. Engine coolant 3-way valve
3. DeNOx 2.2 dosing module
4. Intake air humidity and temperature sensor
5. DeNOx 2.2 supply module
6. DEF tank
7. DEF tank level sensor
8. Urea quality sensor (UQS)
9. Selective Catalytic Reduction (SCR)
10. Exhaust gas temperature sensor upstream of SCR
11. Exhaust valve module
12. Diesel oxidation catalyst (DOC)
13. Exhaust gas temperature sensor upstream of DOC
14. Exhaust gas temperature sensor downstream of SCR
15. NH3 sensor
16. NH3 control unit sensor
17. NOx sensor downstream of SCR

# AVR WIRING

## MX321

Under normal conditions only two adjustments are made to the voltage regulator.

### 1. VOLTS

To adjust generator output voltage.

Clockwise to increase voltage.

### 3. STABILITY

To prevent voltage hunting.

Clockwise to increase the dampening effect.

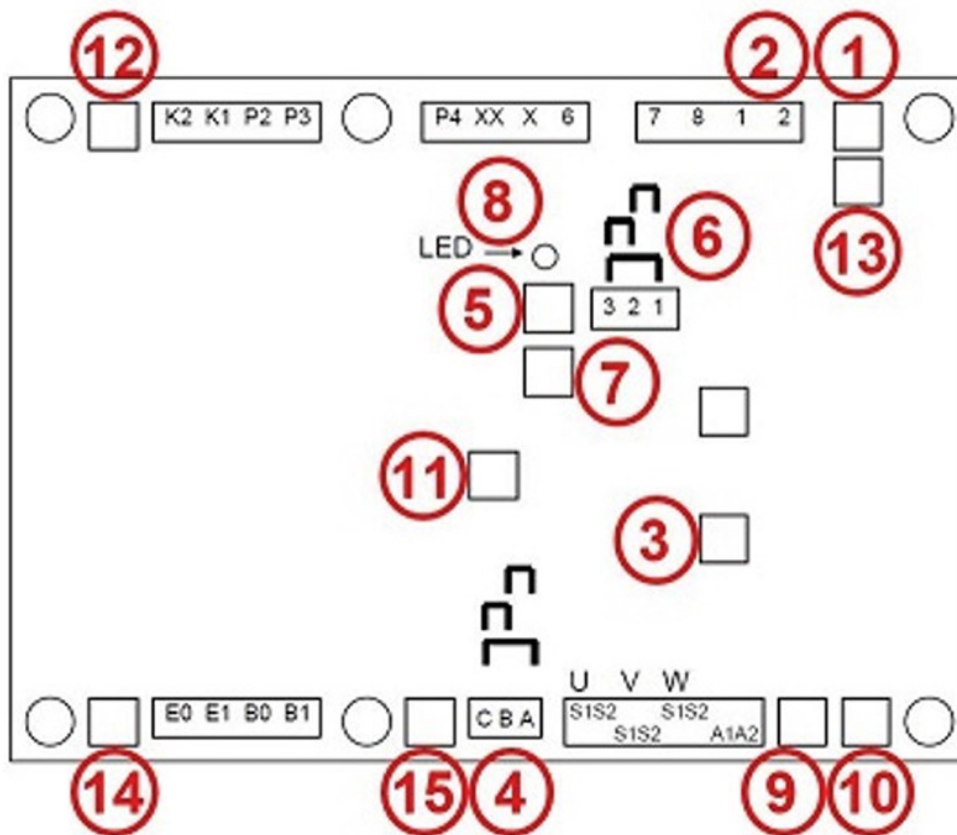

# MAINTENANCE

## WARNING: PERSONAL INJURY/ EQUIPMENT DAMAGE

Place controller in manual mode, e-stop applied first. If an auto start signal comes on during maintenance, it may result in injury, death and equipment damage.

## CHANGING THE OIL

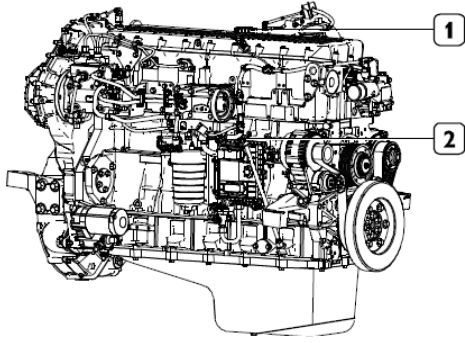

WINCO pipes the oil to drain to the outside for convenient maintenance.

Winco recommends our 5W-40 fully synthetic heavy duty engine oil to give you maximum cold weather protection while maintaining excellent performance in warmer weather. We have partnered with a national lubrication oil manufacturer to give you access to Winco private branded premium oil available at comparable prices to conventional oils. See your dealer for additional information.

## CAUTION: PERSONAL INJURY

Only change oil when the engine is not running and is at a low temperature in order to avoid the risk of burns.

1. Place a drip pan or suitable container for catching the oil. WINCO has supplied a valve on the skid frame to hook a customer supplied 5/8" hose to conveniently run the oil to the drip pan.

Note: There are two drain valves, one for coolant and one for oil.

2. Drain the oil.
3. Once the oil has fully drained, close the valve.
4. Open the oil cap (1) and top-off the filler pipe using lubricant oil with the recommended oil in the LUBRICATION section of this manual.
5. Use the dip stick (2) to ensure the level of oil does not exceed the "MAX" limit.
6. Insert the dipstick and close the oil cap.
7. Dispose of oil in accordance to local codes. DO NOT dispose or allow oil to seep into the ground or sewer systems, doing so will cause environmental damage.

## CHANGING OIL FILTER

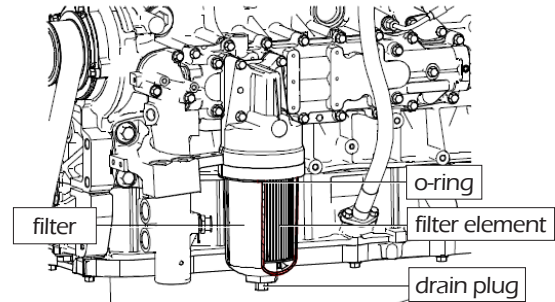

The filter must be replaced when the lubricant oil is changed.

Only use filters with a filtering degree equal to the original filter.

## CAUTION: PERSONAL INJURY

Only change oil when the engine is not running and is at a low temperature in order to avoid the risk of burns.

1. Remove the low oil pressure sensor from the filter mount.
2. Use an oil filter wrench to unscrew and remove the oil filter.
3. Lightly coat the o-ring esal on the new oil filter with engine oil.
4. Install the new engine oil filter manually by screwing on new oil filter canister until sealing ring abuts the filter head and tighten a further 3/4 turn. Do NOT use a strap wrench or similar tool to tighten the filter canister.
5. Warm up the engine by running it for 5 minutes and check for any oil leaks.
6. Recheck the oil level using the dipstick.
7. Add engine oil to engine oil filler port as needed until the level is between the maximum and minimum lines shown on the dipstick.

## CHANGE FUEL FILTER

### WARNING

Do not fill up the new filter before it is fitted to the support, to avoid inserting harmful impurities into the injection system and circuit.

### CAUTION: PERSONAL INJURY

Only change fuel filter when the engine is not running and is at a low temperature in order to avoid the risk of burns.

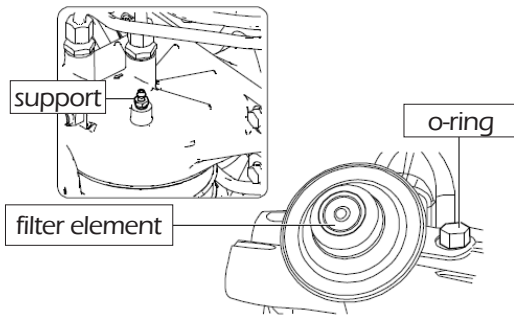

1. Place a suitable container to collect fuel.
2. Remove the filter by unscrewing it. Keep o-ring.
3. Open the drain plug and the bleeder connection and drain any residual fuel.
4. Remove the filter element by unscrewing the relative bell-shaped support
5. Replace the filter element and the O-ring seal container inside the bell-shaped support
6. Moisten the O-ring seal of the filter with oil.
7. Insert the filter element and tighten the relative bell-shaped support to the torque indicated in the table.
8. Tighten the drain plug to the torque indicated in the table.

Description	Torque
Fuel filter	32.5 ±2.5 Nm
Threaded plug	1.5 ±0.5 Nm
Bleeder connection	18 ±2 Nm

9. Loosen the following bleeder connections and connect them with appropriate pipes to allow any residue to drain into suitable containers so as to prevent soiling:
  - a. Screw situated on the pre-filter support.
  - b. Bleeder connection situated on the filter support.
10. Actuate the pump located on the fuel pre-filter until the fuel comes out of the bleed screw with no sign of any air bubbles; upon completion of the operation tighten the screw.
11. Continue to operate the pump until fuel flows out without air from the bleeder connection situated on the fuel filter; upon completion of the operation tighten the screw.

## REPLACING THE FUEL PRE-FILTER

### CAUTION: PERSONAL INJURY

Only replace fuel pre-filter when the engine is not running and is at a low temperature in order to avoid the risk of burns.

1. Place a suitable container to collect fuel.
2. Remove the pre-filter.
3. Moisten the O-ring seal for the new filter with diesel or engine oil.
4. Hand-tighten the new filter in position, so that the sealing gasket is in contact with the support, then torque to 19.5 +/-1 Nm.
5. Reconnect the lower electric connection of the water pressure sensor.

## FILLING COOLANT

### CAUTION: PERSONAL INJURY

Only fill coolant when the engine is not running and is at a low temperature in order to avoid the risk of burns.

### CAUTION: EQUIPMENT DAMAGE

Never use a cold coolant mixture to top up the radiator of a hot engine if the coolant level is very low; this could cause serious engine damage.

1. Ensure the radiator drain valve and the plug on the engine block are secure.
2. Open the valve and slowly pour the coolant into the radiator until it is even with the lip of the filler port.
3. Reinstall radiator cap.

## CHANGING COOLANT

WINCO pipes the coolant to drain to the outside for convenient maintenance.

Engine coolant contaminated with rust or water scale reduces the cooling effect. Even when extended life engine coolant is properly mixed, the engine coolant gets contaminated as its ingredients deteriorate. Drain, flush and refill the cooling system with new coolant every 3000 hours or every 2 years, whichever comes first.

### CAUTION: PERSONAL INJURY

Only proceed when the engine is not running and is at a low temperature in order to avoid the risk of burns.

1. Loosen the seal elements, remove the sleeves connecting the engine circuit to the heat exchanger and wait until it has emptied completely. When empty, repair the circuit making sure that the sleeves are perfectly sealed

2. Refill the engine and the heat exchanger until complete top-off.
3. With the filler cap open, start the engine and keep it idling for nearly one minute. This phase facilitates the cooling liquid air bleed.
4. Stop the engine and top up again.
5. Dispose of coolant in accordance to local codes. DO NOT dispose or allow oil to seep into the ground or sewer systems, doing so will cause environmental damage.

3. Check that there is no dirt. If there is, clean the filter element. Blow dry compressed air through the filter element, from the inside outward (maximum pressure 200 kPa). Do not use detergents; do not use diesel.
4. Replace the filter if any breakages or tears are found.
5. Reassemble by repeating the above operations in reverse order
6. Reinstall the element into the air cleaner case.

## CLEANING RADIATOR

The surfaces of the radiator come into contact with the outside air and can be subject to deposits and impurities. Clean in accordance to the maintenance schedule with compressed air or steam.

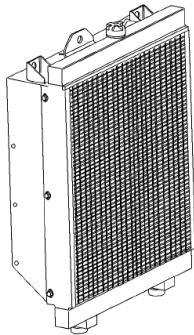

1. Check that the radiator air inlets are free from dirt (dust, mud, straw, etc.).
2. Clean them if necessary, using compressed air or steam.

## CHANGING AIR FILTER

The engine performance is adversely affected when the air cleaner element is clogged with dust.

### WARNING: EQUIPMENT DAMAGE

**Never operate the engine with the air cleaner element removed. This may allow foreign material to enter the engine and damage it. Do NOT remove filter while engine is running.**

### WARNING: EQUIPMENT DAMAGE

**Take care to ensure that the parts are reassembled correctly. Imperfect assembly might result in unfiltered air being sucked into the engine, causing serious damage.**

1. Remove the filter cover after first unscrewing the locking handle.
2. Remove the external cartridge, after unfastening the second locking handle; during this operation, take care to ensure that no dust gets into the sleeve.

## REPLACING BLOW-BY FILTER

### WARNING

**Do NOT perform while the engine is running.**

Unscrew the screws (3) and remove the cover (4)

- Unscrew the screws (2) and remove the blow-by filter element (1).
- Position the new blow-by filter element (1) in its seat.
- Apply some Loctite 243 on the screws (3) and tighten them to the torque indicated in the table.
- Position the cover (4) and tighten the screws (3) to the torque indicated in the table.

14\_131\_C

Carefully clean the filter seat and the cover.

Description	Torque
Fastening screws for blow-by filter element	
Pre-tightening	5 Nm
Tightening	15 Nm
Fastening screws for blow-by cover	7 ± 1 Nm

## STORAGE

### PREPARING THE ENGINE FOR A LONG PERIOD OF INACTIVITY

#### INFINITE PERIOD

In order to prevent oxidation of the internal parts of the engine and of certain components in the injection system, when the engine is expected to be inoperative for periods of more than two months, the following operations must be carried out in preparation for this:

1. Drain the lubricant from the sump, after first warming up the engine.
2. Fill the engine with protective oil type 30/M (or alternatively oil that complies with MIL 2160B type 2 specifications), up to the "minimum" level indicated on the dipstick. Start the engine and keep it running for approximately 5 minutes.
3. Drain the fuel from the injection circuit, from the filter and from the injection pump pipes.

4. Connect the fuel circuit to a tank containing CFB (ISO 4113) protective fluid, and feed in the fluid by putting the circuit under pressure and running the engine for approximately 2 minutes, after first disabling the injection system. This operation can be performed by polarizing terminal 50 of the starter motor with a positive voltage equivalent to the rated voltage of the system, using a conductor provided for that purpose.

5. Nebulize approximately 130 g of 30/M protective oil (10 g per liter displacement) into the turbocharger suction inlet, during the pressurized filling operation described in the previous point.

6. Close all the suction, delivery, ventilation and bleeder openings in the engine with suitable plugs, or seal them with adhesive tape.

7. Drain the residual 30/M protective oil from the sump. This oil can be used again for a further 2 preparation operations.

8. Attach signs reading "ENGINE WITHOUT OIL" to the engine and to the on-board control panel.

9. Drain the coolant, if it has not been mixed with suitable antifreeze and corrosion inhibitors, and affix a sign to indicate the fact. In the event of prolonged inactivity, the operations described must be repeated every 6 months, following the procedure given below:

A) drain the 30/M protective oil from the sump;

B) repeat the operations described from point 2 to point 7.

Should you intend to protect external parts of the engine, proceed by spraying OVER 19 AR protective liquid on unpainted metal parts, such as the flywheel, pulleys and the like, avoiding belts, connector cables and electrical equipment.

#### START-UP AFTER LONG PERIOD OF INACTIVITY

1. Drain the residual protective oil from the sump.
2. Fill the engine with the type and quantity of lubricant oil
3. Drain the CFB protective fluid from the fuel circuit.
4. Remove the plugs and/or seals from the engine's intake, discharge, ventilation and bleeder holes, restoring normal conditions of use. Connect the turbocharger intake inlet to the air filter.
5. Connect the fuel circuits to the fuel tank of the machine completing the operation. During the filling operations, connect the tank fuel return pipe to a collection container to prevent the residual CFB protective liquid from flowing into the tank.
6. Check the engine and top up with coolant as recommended; bleed if necessary.
7. Start the engine and let it idle until completely stabilised.

8. Check that the indications on the dashboard are plausible and that there are no alarm signals.

9. Stop the engine.

10. Remove the warning notices of ENGINE WITHOUT OIL from the engine and dashboard.

#### DEF SYSTEM

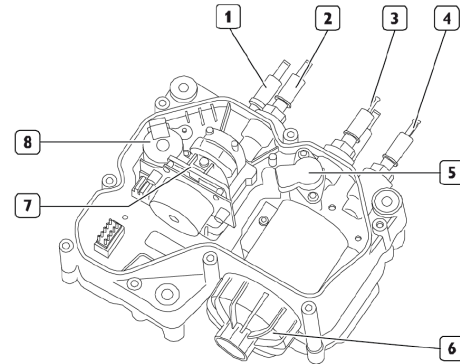

1. Coolant connector
2. DEF inlet from tank
3. DEF back-flow to tank
4. DEF outlet to Dosing Module
5. Pressure sensor
6. Supply Module main-filter
7. Membrane pump
8. 4/2 Way valve.

#### AFTERTREATMENT SYSTEM MAINTENANCE

Refer to the engine manufacturer's operator's manual.

##### WARNING: EQUIPMENT DAMAGE

Failure to replace the main filter can result in damage to the pump and dosing module.

#### MAINTENANCE SCHEDULE

The ultimate aim of a preventive maintenance program is to maintain the equipment in optimum condition, for the maximum amount of time during its useful life. The detection of faults before they develop into major problems will decrease downtime. A regular schedule of cleaning and inspection will help assure trouble-free operation. Personnel responsible for maintenance should set up a schedule for inspection, and cleaning at intervals calculated to keep the equipment in good condition. In making up a schedule, keep the following in mind:

- A. New equipment must be carefully monitored until extended operation has demonstrated that it is performing satisfactorily.

B. Old equipment requires more frequent inspection (and possibly servicing) than similar equipment that has lower hours.

C. Time spent in cleaning, inspecting and correcting minor defects before they become major troubles saves time in overhaul and repair.

DAILY
Check Engine Oil Level
Check Coolant Level and for Leakage
Check Air Filter
Trailer Tire Pressure
MONTHLY
Tighten Trailer Lug Nuts
EVERY 6 MONTHS
Check Electrolyte Level in Battery and Clean Terminals
Check Exhaust System For Damage
Clean Fuel Tank
Check Trailer Axle Grease
EVERY 150 HOURS
Drain Water From Fuel Pre-filter
EVERY 600 HOURS
Drain Water From Fuel Pre-Filter
Check Belts and Belt Tension
Clean Heat Exchanger (Radiator)
Change Oil and Oil Filters
Change Fuel Filters
Change Fuel Pre-filter
EVERY 1200 HOURS
Change Air Filter (May need replacement sooner, depending on conditions)
Change Auxiliary Member Belt
Visually Inspect Turbocharger
EVERY 1800 HOURS
Change Blow-by filter
EVERY 2400 HOURS
Check Tappets Clearance - Adjust if Necessary
EVERY 3000 HOURS
Change Coolant
Visually Inspect Alternator
Clean/Replace Radiator Pressure Cap

The frequency is a function of the environmental conditions and product wear/efficiency. In some operating conditions you may have to accelerate the maintenance schedule. After long periods of inactivity of the engine, carry out the checks before starting the engine. If the warning signal is given indicating that the filter is clogged, the filter must be replaced.

After performing all maintenance operations that require disconnection of the batteries, make sure the clamps have been securely reconnected on the poles.



# TROUBLESHOOTING TABLE

NOTE: Before doing any troubleshooting, check the digital display on the DSE 7310 MKII. Normally, it will tell why the unit has failed. This will shorten your troubleshooting time and in many cases, prevent the replacement of parts that may not be defective.

Problem	Possible Causes
Unit will not crank when power fails	Digital genset not in AUTO Transfer control switch not in AUTOMATIC position Incorrect wiring between ATS and genset Defective control relay in ATS Fuse(s) blown in the DSE 7310 MKII Defective DSE 7310 MKII Loose or dirty battery terminals Defective starter Defective start solenoid Low/dead battery
Engine won't crank	Low/dead battery Blown DC fuses Defective DSE 7310 MKII Defective key switch Loose or dirty battery terminals Defective starter Defective start solenoid Locked up engine genset Defective engine harness Improper battery voltage to start solenoid, fuel pump, or fuel solenoid
Engine cranks but will not start	Improper fuel delivery to the unit Fuel supply shut off Fuel tank empty Air in the fuel system Engine fuel solenoid has not opened Defective fuel pump Defective fuel solenoid Defective engine harness Improper battery voltage to fuel pump or fuel solenoid
Engine starts, then stops and alarm light comes on	Engine oil pressure is low Engine has high water temperature Engine has overspeed Engine has gone into overcrank No output from AC generator Loss of speed signal Loss of run signal
Engine will not come up to speed after it starts	Insufficient fuel volume getting to the unit <ol style="list-style-type: none"> <li>1. Too small of fuel line</li> <li>2. Fuel racks not open properly</li> </ol> Governor is defective AC short in generator components
ATS will not transfer to Emergency Supply (generator)	No AC generator output Defective ATS control board. See ATS manual Circuit breaker open or defective
ATS will not re-transfer to normal power	Proper power line not available at line terminals in ATS panel Defective ATS control board. See ATS manual
No AC output from generator	Defective diode Defective voltage regulator Defective rotor Defective stator Defective exciter rotor Defective exciter stator AC short in the output leads Defective/open generator output breaker Wiring error
Overheating	Unplug the viscous clutch fan controller, Fan will operate at full speed, producing maximum cooling capacity.

# WIRING SIZE TABLE

The table below is based on Table 310.16 in the National Electric Code 2020 edition. Allowable ampacities of insulated conductors rated 0 through 2000V, 75°C through 90°C. Not more than three current-carrying conductors in Raceway, Cable, or Earth (direct buried). Adjust for 40°C (104°F) ambient temperature.

SIZE AWG OR KCMIL	75°C (167°F)	90°C (194°F)	75°C (167°F)	90°C (194°F)
	Wire Type: RHW, THHW, THW, THWN, XHHW, XHWN, USE, ZW	Wire Type: TBS, SA, SIS, FEP, FEPB, MI, PFA, RHH, RHW-2, THHN, THHW, THW-2, THWN-2, USE-2, XHH, XHHW, XHHW-2, XHWN, XHWN-2, XHHN, Z, ZW-2	Wire Type: RHW, THHW, THW, THWN, XHHW, USE	Wire Type: TBS, SA, SIS, THHN, THW-2, THWN-2, RHH, RHW- 2, USE-2, XHH, XHHW, XHHW- 2, ZW-2
	COPPER		ALUMINUM OR COPPER-CLAD ALUMINUM	
8	50	55	40	45
6	65	75	50	55
4	85	95	65	75
3	100	115	75	85
2	115	130	90	100
1	130	145	100	115
1/0	150	170	120	135
2/0	175	195	135	150
3/0	200	225	155	175
4/0	230	260	180	205
250	255	290	205	230
300	285	320	230	260
350	310	350	250	280
400	335	380	270	305
500	380	430	310	350
600	420	475	340	385
700	460	520	375	425
750	475	535	385	435
800	490	555	395	445
900	520	585	425	480
1000	545	615	445	500
1250	590	665	485	545
1500	625	705	520	585
1750	650	735	545	615
2000	665	750	560	630

For additional information, see table 310.16 of the National Electric Code.

# WIRING DIAGRAMS

## THREE PHASE AC WIRE LOW WYE

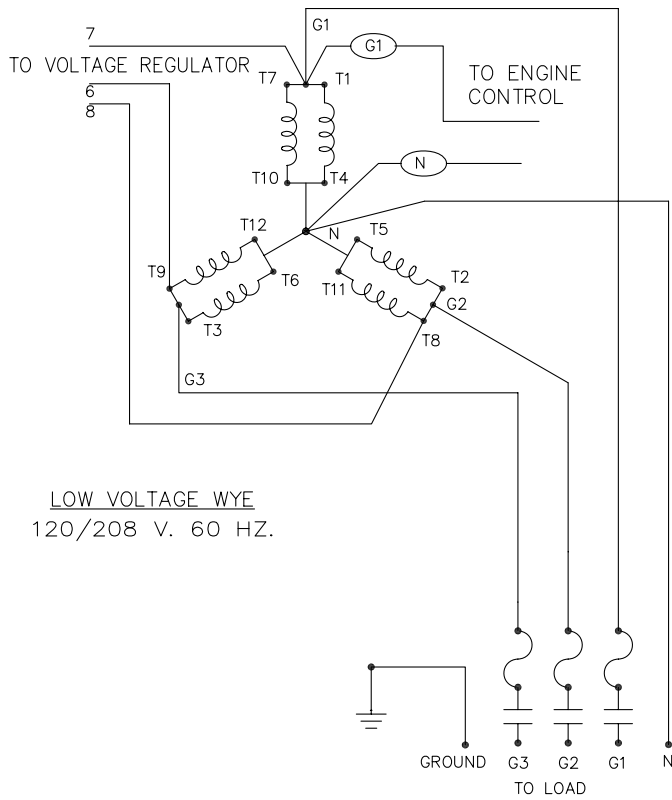

## THREE PHASE AC WIRE HIGH WYE

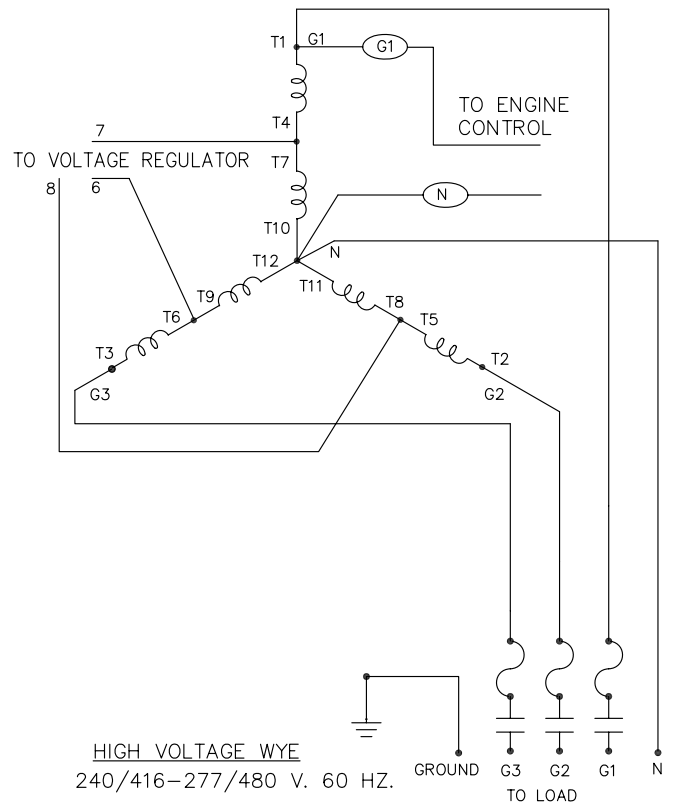

# DSE 7310 MKII WIRING DIAGRAM

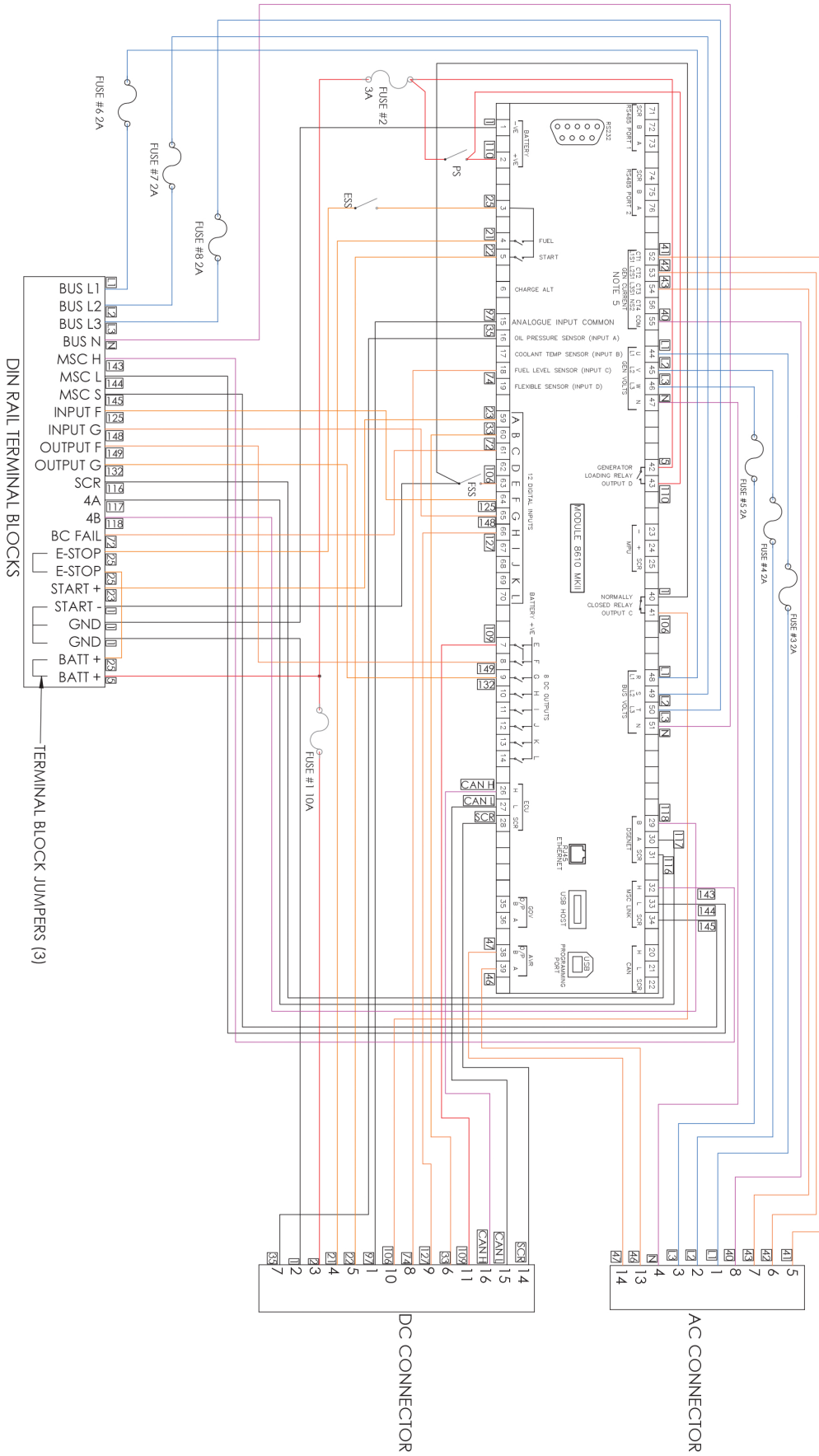

# ENGINE CODES

SPN	FMI	Test Translation	DTC
27	3	The electrical Signal of the EGR Valve position sensor is monitored. In case of defect recognition a replacement value is taken.	1B-3
27	4	The electrical Signal of the EGR Valve position sensor is monitored. In case of defect recognition a replacement value is taken.	1B-4
51	3	The electrical Signal of the TVA position sensor is monitored. In case of defect recognition a replacement value is taken.	33-3
51	4	The electrical Signal of the TVA position sensor is monitored. In case of defect recognition a replacement value is taken.	33-4
97	15	The Water in fuel detection is carried out with a digital sensor placed in fuel filter	61-F
100	2	Engine oil pressure value is monitored for plausibility, when engine is stopped, pressure should be lower than a defined maximum value, detected by an oil pressure digital switch. Oil Pressure signal is acquired from oil pressure sensor connected via hardware pin, signal is acquired via digital sensor (DIO)	64-2
100	17	Engine oil pressure value is monitored for plausibility, when engine is running, pressure should be higher than a defined minimum value, detected by an oil pressure digital switch. Oil Pressure signal is acquired from oil pressure sensor connected via hardware pin, signal is acquired via digital sensor (DIO)	64-11
102	3	The electrical Signal of the boost pressure sensor is monitored. In case of defect recognition a replacement value is taken.	66-3
102	4	The electrical Signal of the boost pressure sensor is monitored. In case of defect recognition a replacement value is taken.	66-4
102	20	The plausibility of boost pressure measured under low speed and load conditions is monitored. Boost pressure is compared with environmental pressure.	66-14
102	21	The plausibility of boost pressure measured under low speed and load conditions is monitored. Boost pressure is compared with environmental pressure.	66-15
105	3	The electrical Signal of the air temperature sensor upstream engine Inlet Valve, is monitored. In case of defect recognition a substitute value is taken.	69-3
105	4	The electrical Signal of the air temperature sensor upstream engine Inlet Valve, is monitored. In case of defect recognition a substitute value is taken.	69-4
108	3	Environmental pressure sensor is available and connected via hardware to the ECM. Pressure is obtained through Analogic to Digital Converter and transformed to a physical value in EnvP_pSens. A signal range check is performed on the signal. Sensor is inside ECU.	6C-3
108	4	Environmental pressure sensor is available and connected via hardware to the ECM. Pressure is obtained through Analogic to Digital Converter and transformed to a physical value in EnvP_pSens. A signal range check is performed on the signal. Sensor is inside ECU."	6C-4
110	3	Electrical Signal range check of Coolant temperature sensor	6E-3
110	4	Electrical Signal range check of Coolant temperature sensor Coolant temperature voltage below or shorted to low source	6E-4
110	15	Two engine temperature thresholds are available to signal high engine temperature. Pre-warning is set if engine temperature > 101,96°C Warning is set if engine temperature > 105,96°C	6E-F
110	16	Two engine temperature thresholds are available to signal high engine temperature. Pre-warning is set if engine temperature > 101,96°C Warning is set if engine temperature > 105,96°C"	6E-10
152	2	A software internal failure occurred which lead to a software reset. This reset caused a failure which is only visible for manufacturer specific testers.	98-2
157	0	This function is used for monitoring the rail pressure when the rail control loop is in limp home mode operated with a PRV.	9D-0
157	2	The Fuel Rail pressure control is executed with a device: Metering Unit (MeUn) as feeding quantity control and an overpressure valve allocate in the rail (PRV).The desired fuel quantity to reach the requested rail pressure is higher than expected at idle speed, a leaky system must be assumed.	9D-2
157	3	Electric monitoring of Fuel Rail Pressure sensor	9D-3
157	4	Electric monitoring of Fuel Rail Pressure sensor	9D-4
157	10	A loose contact in the rail pressure sensor wiring can lead to incorrect measuring of the rail pressure. If this does occur, typically the measured pressure rises considerably for a brief time (jumps > 500,00bar in a 10 ms window). This kind of extreme pressure increase does not occur in the system. To determine a malfunction based on this appearance, gradient monitoring of the rail pressure is performed.	9D-A
157	16	The Fuel Rail pressure control is executed with a device: Metering Unit (MeUn) as feeding quantity control and an overpressure valve allocate in the rail (PRV). The Fuel Rail pressure control is executed via Metering Unit (MeUn) as feeding quantity control and pressure sensor. The Fuel Rail pressure control is executed with a device: Metering Unit (MeUn) as feeding quantity control and an overpressure valve allocate in the rail (PRV). High pressure system leakage is checked at overrun.	9D-10
157	17	The minimum rail pressure value necessary to allow fuel injection is monitored.	9D-11

SPN	FMI	Test Translation	DTC
157	18	The Fuel Rail pressure control is executed with a device: Metering Unit (MeUn) as feeding quantity control and an overpressure valve allocate in the rail (PRV).	9D-12
166	2	Dataset Interlock Feature is used to prevent the flashing of unintended datasets on to the ECU during any SW upgrades in field. This fault path is used to indicate if there was an error during a Write/Read EEPROM operation.	A6-2
166	14	Dataset Interlock Feature is used to prevent the flashing of unintended datasets on to the ECU during any SW upgrades in field. This fault path is used to indicate if there was an error during a Write/Read EEPROM operation.	A6-E
168	3	Static monitoring (signal range check) of the battery voltage.	A8-3
168	4	Static monitoring (signal range check) of the battery voltage.	A8-4
172	3	Environmental temperature sensor is available and connected via hardware to the ECM. Temperature is obtained through Analogic to Digital Converter and transformed to a physical value in EnvT_tSens. A signal range check is performed on the signal.	AC-3
172	4	Environmental temperature sensor is available and connected via hardware to the ECM. Temperature is obtained through Analogic to Digital Converter and transformed to a physical value in EnvT_tSens. A signal range check is performed on the signal.	AC-4
174	3	The electrical Signal of the Fuel temperature sensor is monitored. In case of defect recognition a default value for the fuel temperature is taken. In case of defect a fix value or the actual engine temperature can be taken as substitution, depending on configuration (by data set) and reliability of the sensors.	AE-3
174	4	The electrical Signal of the Fuel temperature sensor is monitored. In case of defect recognition a default value for the fuel temperature is taken. In case of defect a fix value or the actual engine temperature can be taken as substitution, depending on configuration (by data set) and reliability of the sensors.	AE-4
190	8	The Engine Position Management module is responsible for signals from camshaft and crankshaft sensor evaluation: angle and speed determination, signal plausibility and quality are monitored by this module. Presence of crankshaft speed signal is monitored here.	BE-8
190	15	Engine speed is monitored and in case of overspeed detection a failure is reported. Unacceptably high engine speed may arise in the event of an error in the ECM or under certain operating states like downhill travel, in this case the failure should does not indicate an error but simply informs about a "misuse" of the engine.	BE-F
593	31	Assuming the condition to enable the engine shut off then the engine will shut down after a countdown timer. The status signal indicates when the countdown timer has elapsed (CoEng_stdIshDwnStM_mp=3). The monitor is triggered by Fid_CoEngIdleShDwnLvl2.	251-1F
594	31	The engine coordinator stop function provides the system with the status for engine shut off, low idle and crank control depending on the various input conditions of engine speed, vehicle speed, vehicle speed sensor defect, engine start status, parking brake switch status and stop switch input. For the idle shut down a state machine is used. The state in which the state machine is at the moment is shown in the message CoEng_stdIshDwnStM_mp. Assuming the conditions to enable the engine shut off then the engine will shut down after a countdown timer. The status signal indicates when the countdown timer is below a timer calibrated (CoEng_stdIshDwnStM_mp=1)."	252-1F
623	6	The Power stage of Stop Lamp is monitored by Hardware for electric failures.	26F-6
624	6	The Power stage of Warning Lamp is monitored by Hardware for electric failures.	270-6
630	2	The injectors are corrected individually (IMA Code) to guarantee exact fuel injection quantity of each injector from lowest to highest fuel quantity. The correction is done at the end of production line (EOL) and after substitution of the injectors with the tester. The data's are stored in the EEPROM. The stored values in the EEPROM are protected with checksum parameters. At each Key 15 "on" the correction data's are read from the EEPROM and checked, if the values are plausible and the checksums are correct. If not, the injector will not be corrected and a failure will be stored.	276-2
637	11	The Engine Position Management module is responsible for signals from camshaft and crankshaft sensor evaluation: angle and speed determination, signal plausibility and quality are monitored by this module. Plausibility between camshaft and crankshaft speed sensor signal is monitored here.	27D-B
639	9	The message TSC1VE contains the information for torque/speed demand from Vehicle Controller to EDC. TSC1 CAN messages (Torque/Speed Control) are sent at fast rate if Torque/speed request is active and at slower rate if no request is active, to reduce CAN traffic, so different timeout monitor are provided: a fast one if a request is active (active timeout), and a slow one if no request is active (passive timeout).	27F-9
651	5	Hardware errors in the injectors and respective ECM power stages are investigated. Diagnostic procedure uses pattern detection to identify specific errors and trigger appropriate substitute reaction. The behavior pattern describes in a bit mask different detected problem (overcurrent, command collision, RAM error,short circuit,...) when the expected combination of errors is detected (measured and reference pattern are matching) a failure is detected.	28B-5
651	6	Hardware errors in the injectors and respective ECM power stages are investigated. Diagnostic procedure uses pattern detection to identify specific errors and trigger appropriate substitute reaction. The behavior pattern describes in a bit mask different detected problem (overcurrent, command collision, RAM error,short circuit,...) when the expected combination of errors is detected (measured and reference pattern are matching) a failure is detected.	28B-6
651	20	ZFL functionality (Zero Fuel Calibration during Low Idle) evaluates energizing time for injectors at low idle. The ZFL is changing the energizing time of the pilot injection by adding the learned calibration values. A monitoring of these learn values is required.	28B-14
651	21	ZFL functionality (Zero Fuel Calibration during Low Idle) evaluates energizing time for injectors at low idle. The ZFL is changing the energizing time of the pilot injection by adding the learned calibration values. A monitoring of these learn values is required.	28B-15

SPN	FMI	Test Translation	DTC
652	5	Hardware errors in the injectors and respective ECM power stages are investigated. Diagnostic procedure uses pattern detection to identify specific errors and trigger appropriate substitute reaction. The behavior pattern describes in a bit mask different detected problem (overcurrent, command collision, RAM error,short circuit,...) when the expected combination of errors is detected (measured and reference pattern are matching) a failure is detected.	28C-5
652	6	Hardware errors in the injectors and respective ECM power stages are investigated. Diagnostic procedure uses pattern detection to identify specific errors and trigger appropriate substitute reaction. The behavior pattern describes in a bit mask different detected problem (overcurrent, command collision, RAM error,short circuit,...) when the expected combination of errors is detected (measured and reference pattern are matching) a failure is detected.	28C-6
652	20	ZFL functionality (Zero Fuel Calibration during Low Idle) evaluates energizing time for injectors at low idle. The ZFL is changing the energizing time of the pilot injection by adding the learned calibration values. A monitoring of these learn values is required.	28C-14
652	21	ZFL functionality (Zero Fuel Calibration during Low Idle) evaluates energizing time for injectors at low idle. The ZFL is changing the energizing time of the pilot injection by adding the learned calibration values. A monitoring of these learn values is required.	28C-15
653	5	Hardware errors in the injectors and respective ECM power stages are investigated. Diagnostic procedure uses pattern detection to identify specific errors and trigger appropriate substitute reaction. The behavior pattern describes in a bit mask different detected problem (overcurrent, command collision, RAM error,short circuit,...) when the expected combination of errors is detected (measured and reference pattern are matching) a failure is detected.	28D-5
653	6	Hardware errors in the injectors and respective ECM power stages are investigated. Diagnostic procedure uses pattern detection to identify specific errors and trigger appropriate substitute reaction. The behavior pattern describes in a bit mask different detected problem (overcurrent, command collision, RAM error,short circuit,...) when the expected combination of errors is detected (measured and reference pattern are matching) a failure is detected.	28D-6
653	20	ZFL functionality (Zero Fuel Calibration during Low Idle) evaluates energizing time for injectors at low idle. The ZFL is changing the energizing time of the pilot injection by adding the learned calibration values. A monitoring of these learn values is required.	28D-14
653	21	ZFL functionality (Zero Fuel Calibration during Low Idle) evaluates energizing time for injectors at low idle. The ZFL is changing the energizing time of the pilot injection by adding the learned calibration values. A monitoring of these learn values is required.	28D-15
654	5	Hardware errors in the injectors and respective ECM power stages are investigated. Diagnostic procedure uses pattern detection to identify specific errors and trigger appropriate substitute reaction. The behavior pattern describes in a bit mask different detected problem (overcurrent, command collision, RAM error,short circuit,...) when the expected combination of errors is detected (measured and reference pattern are matching) a failure is detected.	28E-5
654	6	Hardware errors in the injectors and respective ECM power stages are investigated. Diagnostic procedure uses pattern detection to identify specific errors and trigger appropriate substitute reaction. The behavior pattern describes in a bit mask different detected problem (overcurrent, command collision, RAM error,short circuit,...) when the expected combination of errors is detected (measured and reference pattern are matching) a failure is detected.	28E-6
654	20	ZFL functionality (Zero Fuel Calibration during Low Idle) evaluates energizing time for injectors at low idle. The ZFL is changing the energizing time of the pilot injection by adding the learned calibration values. A monitoring of these learn values is required.	28E-14
654	21	ZFL functionality (Zero Fuel Calibration during Low Idle) evaluates energizing time for injectors at low idle. The ZFL is changing the energizing time of the pilot injection by adding the learned calibration values. A monitoring of these learn values is required.	28E-15
676	5	The Power stage of glow plug is monitored by hardware for electric failures. In case of a relay between ECU and Glow plug, the failure can be caused by the relay and not by the glow plug. If there is no intelligent relay, real electric failure of glow plug can not be detected. This monitor is used for Glow Plug of Low Voltage System (GCU-T), not used for FUSO applications The Power stage of glow plug is monitored by Hardware for electric failures. In case of a relay between ECU and Glow plug, the failure can be caused by the relay and not by the glow plug. If there is no intelligent relay, real electric failure of glow plug can not be detected.	2A4-5
676	6	The Power stage of glow plug is monitored by Hardware for electric failures. In case of a relay between ECU and Glow plug, the failure can be caused by the relay and not by the glow plug. If there is no intelligent relay, real electric failure of glow plug can not be detected. This monitor is used for Glow Plug of Low Voltage System (GCU-T), not used for FUSO applications The Power stage of glow plug is monitored by Hardware for electric failures. In case of a relay between ECU and Glow plug, the failure can be caused by the relay and not by the glow plug. If there is no intelligent relay, real electric failure of glow plug can not be detected.	2A4-6
676	19	The Power stage of glow plug is monitored by Hardware for electric failures. In case of a relay between ECU and Glow plug, the failure can be caused by the relay and not by the glow plug. If there is no intelligent relay, real electric failure of glow plug can not be detected. This monitor is used for Glow Plug of Low Voltage System (GCU-T), not used for FUSO applications	2A4-13
677	3	Engine Starter is controlled by two relays actuators one for Low Side and one for High Side. Both power stages are monitored by Hardware for electric failures.	2A5-3
677	5	Engine Starter is controlled by two relays actuators one for Low Side and one for High Side. Both power stages are monitored by Hardware for electric failures.	2A5-5

SPN	FMI	Test Translation	DTC
677	6	Engine Starter is controlled by two relays actuators one for Low Side and one for High Side. Both power stages are monitored by Hardware for electric failures.	2A4-6
723	8	The Engine Position Management module is responsible for signals from camshaft and crankshaft sensor evaluation: angle and speed determination, signal plausibility and quality are monitored by this module. Plausibility of number and position of the camshaft edges detected by camshaft speed sensor is monitored here.	2D3-8
977	12	The post drive control, controls the system state which is activated by switching key15 off. Test and management tasks are carried out here. Shut off time of CY320 (power stage supplier) is monitored.	3D1-C
1076	2	A loose contact in the wiring of the metering unit can result in a malfunction of the metering unit and lead to fuel pressure oscillations (irregular engine running, possible Fuel pressure failures detected). A permanent loosen contact is detected by the electrical monitoring (SCB,SCG,OL Monitorings), but very short contact loosing (e.g. due to vibration) are not detected. Therefore this monitoring counts the number "short term loosen contacts" (shorter than debouncing of electrical failure) in the way, that a counter is incremented by one each time a loosen contact is recognized, and decremented by 1, if the time between 2 loosen contact recognitions is longer than 3,00s. If the counter reaches or exceeds 1000,00- a "bad contact" will be recognized.	434-2
1076	5	The power stage of the fuel metering unit to common rail (MeUn) is monitored electrically for voltage and current by hardware. The Power stage of Metering Unit at Low Side is monitored by Hardware for electric failures.	434-5
1076	6	The power stage of the fuel metering unit to common rail (MeUn) is monitored electrically for voltage and current by hardware. The Power stage of Metering Unit at Low Side is monitored by Hardware for electric failures.	434-6
1081	5	The Power stage for the control lamp for Glow Plug activation is controlled by Hardware for electrical failures	439-5
1081	6	The Power stage for the control lamp for Glow Plug activation is controlled by Hardware for electrical failures	439-6
1127	16	Boost pressure value is monitored, if actual boost pressure is higher than target boost pressure beside a defined threshold a failure is detected.	467-10
1127	18	Pressure Charger Regulator is monitored for any deviation of actual boost pressure from target pressure. Underboost is detected if the engine is running within the specified working area and a positive boost pressure deviation is detected.	467-12
1188	5	The Power stage of Bitron actuator is monitored by Hardware for electric failures.	4A4-5
1188	6	The Power stage of VGT actuator is monitored by Hardware for electric failures. The Power stage of Bitron actuator is monitored by Hardware for electric failures.	4A4-6
1209	3	The turbine upstream pressure is acquired via hardware connected sensor. The raw voltage signal is acquired in the message Exh_uRawPTrbnUs. This signal is checked for the Signal Range Errors and then transformed into physical value Exh_pSensPTrbnUs.	4B9-3
1209	4	The turbine upstream pressure is acquired via hardware connected sensor. The raw voltage signal is acquired in the message Exh_uRawPTrbnUs. This signal is checked for the Signal Range Errors and then transformed into physical value Exh_pSensPTrbnUs.	4B9-4
1221	2	Communication between ECM processor and power stage controller over SPI bus is monitored. Error is detected if no response or an erroneous response is detected by the processor.	4C5-2
1239	0	The Fuel Rail pressure control is executed with a device: Metering Unit (MeUn) as feeding quantity control and an overpressure valve allocate in the rail (PRV). The desired fuel flow is adjusted by feed back control for reaching the desired fuel pressure. If this needed fuel flow exceeds a maximal expected fuel flow by more than a fuel flow dependent value (15700,00mm3/s at 4500,00mm3/s to 14000,00mm3/s at 14330,00mm3/s), leakage in the system must be assumed.	4D7-0
1485	7	"The Main relay is controlled by the ECU itself: After Key 15 off the ECU goes into the ""After-run"", where mainly following actions are made: - storage of the failures into the memory - counting of driving cycles and the corresponding reactions (pending -> validated failure, failure declared as long time failure etc.) Therefore the Main Relay is controlled by the ECU to assure the After-run. The main Relay is switched off by the ECU itself after the After-run has finished. After the request of "Main Relay switch off" the ECU expects, that the supply voltage drops below limit within 500,00ms. If not, it is assumed that the main relay is stuck in closed position.	5CD-7
1485	14	The Main relay is controlled by the ECU itself: After Key 15 off the ECU goes into the ""After-run"", where mainly following actions are made: - storage of the failures into the memory - counting of driving cycles and the corresponding reactions (pending -> validated failure, failure declared as long time failure etc.) Therefore the Main Relay is controlled by the ECU to assure the After-run. The main Relay is switched off by the ECU itself after the After-run has finished. This means, that all this actions can not be done, if the Main relay switches off before the After-run has finished. Therefore the correct opening of Main Relay is monitored. At each start a bit in the EEPROM is set, which is reset to 0 at the end of the After-run immediately before the ECU switches off the Main Relay. At next start the System checks the state of the bit in the EEPROM: If it is still set, this means that the Main Relay was switched off before the request of the ECU.	5CD-E
2791	5	The Power stage of electric EGR Valve actuator (H-Bridge) is monitored by Hardware for electric failures. The Power stage of electric EGR Valve actuator (H-Bridge) is monitored by Hardware for electric failures. The H-Bridge has 2 switches (High side and Low side). Each circuit is monitored separately. The Power stage of electric EGR Valve actuator (H-Bridge) is monitored by Hardware for electric failures.	AE7-5



SPN	FMI	Test Translation	DTC
2791	6	The Power stage of EGR Valve actuator is monitored by Hardware for electric failures. The Power stage of electric EGR Valve actuator (H-Bridge) is monitored by Hardware for electric failures. The H-Bridge has 2 switches (High side and Low side). Each circuit is monitored separately. The Power stage of electric EGR Valve actuator (H-Bridge) is monitored by Hardware for electric failures. An overload error is not detectable directly in case the wiring length is > 1m and the failure occurs near the actuator. Therefore a plausibility check is made in case a failure "Short circuit to Battery" (SCB) or "Short circuit to Ground" (SCG) is detected. Therefore the switch (Low side in case of SCB, High side in case of SCG) is closed. If the Short Circuit failure disappears, it is cleared and the Overload failure activated.	AE7-6
2791	7	The EGR Valve actuator gives a feedback with a position sensor. If there is a positive deviation between required and measured position, the failure is activated. The system tries then to "unblock" the actuator closing or opening it fast. If it is not possible to "unblock" the actuator, the failure "Jammed Valve" is activated.	AE7-7
2797	6	Hardware errors in the injectors and respective ECM power stages are investigated. Diagnostic procedure uses pattern detection to identify specific errors and trigger appropriate substitute reaction. The behavior pattern describes in a bit mask different detected problem (over current, command collision, RAM error,short circuit,...) when the expected combination of errors is detected (measured and reference pattern are matching) a failure is detected. Two banks are present.	AED-6
2797	7	Hardware errors in the injectors and respective ECM power stages are investigated. Diagnostic procedure uses pattern detection to identify specific errors and trigger appropriate substitute reaction. The behavior pattern describes in a bit mask different detected problem (overcurrent, command collision, RAM error,short circuit,...) when the expected combination of errors is detected (measured and reference pattern are matching) a failure is detected.	AED-7
2798	6	Hardware errors in the injectors and respective ECM power stages are investigated. Diagnostic procedure uses pattern detection to identify specific errors and trigger appropriate substitute reaction. The behavior pattern describes in a bit mask different detected problem (over current, command collision, RAM error,short circuit,...) when the expected combination of errors is detected (measured and reference pattern are matching) a failure is detected. Two banks are present.	AEE-6
2840	12	The hardware encapsulation of CY320 performs a diagnostic of the sensor supplies and monitors the communication Between processor and voltage supply device CY320. A functionality for reading writing and erasing values to a memory media (Flash or EEPROM) is available. These operations are monitored and if problems arise a failure is reported. Communication between CJ945 (power stage chips) and CY320 (power stage voltage supplier) is monitored. The HWE-module R2S2 is the LowLevel Chipdriver for the Powerstage-Chips R2S25200kfp. The R2S25200 is a chip with 18 power stages and an additional module for the monitoring of the ECU internal 5V Supply-Voltage. It is possible to configure max. 4 R2S2.	B18-C
2840	14	Calibrated parameters for baud rate cannot be read from EEPROM	B18-E
2880	2	A range and plausibility check for the value of PTO switch are performed. The source for the multi value PTO switch is an analogic input.	B40-2
2880	3	A range and plausibility check for the value of PTO switch are performed. The source for the multi value PTO switch is an analogic input.	B40-3
2880	4	A range and plausibility check for the value of PTO switch are performed. The source for the multi value PTO switch is an analogic input.	B40-4
3242	0	Physical signal range check: Exhaust Temperature before EGR exit can not exceed physically 799,96°C. If the measured value is higher, the sensor signal is not reliable.	CAA-0
3242	3	The electrical Signal of the Particle Filter temperature upstream sensor is monitored. In case of defect recognition a substitute value is taken.	CAA-3
3242	4	The electrical Signal of the Particle Filter temperature upstream sensor is monitored. In case of defect recognition a substitute value is taken.	CAA-4
3358	10	The system evaluates the main physical parameters of engine (intake temperature and pressure, lambda, EGR position, temperature and pressure in exhaust path) in order to discover a leakage on path from compressor downstream and intake path.	D1E-A
3509	2	The hardware encapsulation of CY320 performs a diagnostic of the sensor supplies and monitors the communication Between processor and voltage supply device CY320. For reasons of safety the ECM provides 3 independent 5V voltage supplies for the sensors. These sensor supply voltages are monitored to ensure they remain within a given range. This check for voltage limits is done autonomously by the hardware (thresholds not applicable).	DB5-2
3510	2	The hardware encapsulation of CY320 performs a diagnostic of the sensor supplies and monitors the communication Between processor and voltage supply device CY320.For reasons of safety the ECM provides 3 independent 5V voltage supplies for the sensors. These sensor supply voltages are monitored to ensure they remain within a given range. This check for voltage limits is done autonomously by the hardware (thresholds not applicable).	DB6-2
3511	2	The hardware encapsulation of CY320 performs a diagnostic of the sensor supplies and monitors the communication Between processor and voltage supply device CY320. For reasons of safety the ECM provides 3 independent 5V voltage supplies for the sensors. These sensor supply voltages are monitored to ensure they remain within a given range. This check for voltage limits is done autonomously by the hardware (thresholds not applicable).	DB7-2
3719	0	When filter regeneration is insufficient, due too prolonged city driving cycle (low exhaust temperatures) or DOC is damaged (no feed gas produced), filter flow resistance can increase above critical values.	E87-0
3719	16	When filter regeneration is insufficient, due too prolonged city driving cycle (low exhaust temperatures) or DOC is damaged (no feed gas produced), filter flow resistance can increase above critical values.	E87-10

SPN	FMI	Test Translation	DTC
4009	5	The Power stage of Fuel Filter heater is monitored by Hardware for electric failures.	FA9-5
4009	6	The Power stage of Fuel Filter heater is monitored by Hardware for electric failures.	FA9-6
4765	3	The electrical Signal of the Oxi Cat temperature upstream sensor is monitored. In case of defect recognition a substitute value is taken.	129D-3
4765	4	The electrical Signal of the Oxi Cat temperature upstream sensor is monitored. In case of defect recognition a substitute value is taken.	129D-4
5319	31	Duration of regeneration is monitored. If maximum defined time is exceeded failure is detected	14C7-1F
5324	7	The Power stage of glow plug is monitored by Hardware for electric failures. In case of a relay between ECU and Glow plug, the failure can be caused by the relay and not by the glow plug. If there is no intelligent relay, real electric failure of glow plug can not be detected. In the system are present a low voltage system (metal or ceramic glow plug).	14CC-7
5325	7	The Power stage of glow plug is monitored by Hardware for electric failures. In case of a relay between ECU and Glow plug, the failure can be caused by the relay and not by the glow plug. If there is no intelligent relay, real electric failure of glow plug can not be detected. In the system are present a low voltage system (metal or ceramic glow plug).	14CD-7
5326	7	The Power stage of glow plug is monitored by Hardware for electric failures. In case of a relay between ECU and Glow plug, the failure can be caused by the relay and not by the glow plug. If there is no intelligent relay, real electric failure of glow plug can not be detected. In the system are present a low voltage system (metal or ceramic glow plug).	14CE-7
5327	7	The Power stage of glow plug is monitored by Hardware for electric failures. In case of a relay between ECU and Glow plug, the failure can be caused by the relay and not by the glow plug. If there is no intelligent relay, real electric failure of glow plug can not be detected. In the system are present a low voltage system (metal or ceramic glow plug).	14CF-7
5419	5	The Power stage of electric Throttle Valve actuator (H-Bridge) is monitored by Hardware for electric failures. The Power stage of electric Throttle Valve actuator (H-Bridge) is monitored by Hardware for electric failures. The H-Bridge has 2 switches (High side and Low side). Each circuit is monitored separately. The Power stage of electric Throttle Valve actuator (H-Bridge) is monitored by Hardware for electric failures.	152B-5
5419	6	The Power stage of Throttle Valve actuator is monitored by Hardware for electric failures. The Power stage of electric Throttle Valve actuator (H-Bridge) is monitored by Hardware for electric failures. The H-Bridge has 2 switches (High side and Low side). Each circuit is monitored separately. A plausibility check is made in case a failure "Short circuit to Battery" (SCB) or "Short circuit to Ground" (SCG) is detected. Therefore the switch (Low side in case of SCB, High side in case of SCG) is closed. If the Short Circuit failure disappears, it is cleared and the Overload failure activated.	152B-6
5419	7	The Throttle Valve actuator gives a feedback with a position sensor. If there is a deviation between required and measured position, the failure is activated. The system tries then to "unblock" the actuator closing or opening it fast. If it is not possible to "unblock" the actuator, the failure "Jammed Valve" is activated.	152B-7
5571	10	"To determine mechanical wear out, the Pressure Relief Valve can be forced to open by performing a defined rail pressure shock in two steps: - Waiting for rail pressure build up - Performing pressure shock The two steps are recorded in the failure memory. Pressure shock is only possible in a defined engine speed/injection quantity range."	15C3-E
5571	14	For determination of the mechanical state of the pressure relief valve it is detected, if the pressure relief valve is forced to open too many times. The monitoring of the wear out of the PRV is done by counting the number of times the PRV is opened and the duration of its opening. The duration of opening (PRV_tiOpn_mp) is accumulated in every driving cycle and stored in the EEPROM in after run state of the engine. If the PRV was open for a longer time than the applied limit a failure is detected.	15C3-E
5571	16	If rail pressure exceeds normal operation values a mechanical valve (PRV= pressure Relief Valve) is opened to control maximum rail pressure	15C3-10
5571	2	PRV is classified as open after the successful evaluation of the rail pressure gradients After this the rail pressure averaging is executed continuously. If the average rail pressure is outside the expected range the open evaluation of the pressure relief valve by rail pressure averaging failed	15C3-2
5571	7	To determine mechanical wear out, the Pressure Relief Valve can be forced to open by performing a defined rail pressure shock in two steps: - Waiting for rail pressure build up - Performing pressure shock The two steps are recorded in the failure memory. Pressure shock is only possible in a defined engine speed/injection quantity range.	15C3-7
5826	16	Euro VI and US2010 legislations require special measures to induce proper functionality of SCR and EGR systems in Heavy Duty engines. SCR and EGR system related faults are monitored and trigger different warning and reaction. The inducements start with a driver warning, then a torque reduction follows and if the fault is not fixed, a creep mode with strongly reduced maximal vehicle speed is activated. Failures which trigger inducements are grouped in 5 different categories: - EGR Valve Blocked - Interruption of Dosing - Reagent Consumption - Reagent Quality - Tampering The inducement logic is applied also a DPF to avoid its irreversible damage or its tampering.	16C2-10

# CALIFORNIA EMISSION CONTROL WARRANTY STATEMENT

## YOUR WARRANTY RIGHTS AND OBLIGATIONS

California Air Resources Board and FPT Industrial S.p.A. are pleased to explain the emission control system warranty on 2021 through 2023 off-road diesel engines. In California, new heavy-duty off-road engines must be designed, built and equipped to meet the State's stringent anti-smog standards. FPT Industrial S.p.A. must warrant the emission control system on your engine for the periods of time listed below provided there has been no abuse, neglect or improper maintenance of your engine.

Your emission control system may include parts such as the fuel injection system and the air induction system. Also included may be hoses, belts, connectors and other emission-related assemblies.

Where a warrantable condition exists, FPT Industrial S.p.A. will repair your heavy-duty off-road engine at no cost to you including diagnosis, parts and labor.

### MANUFACTURER'S WARRANTY COVERAGE:

The 2021-2023 heavy-duty off-road engines are warranted for 5 years or 3000 hours, whichever comes first. If any emission-related part on your engine is defective, the part will be repaired or replaced by FPT Industrial S.p.A.

### OWNER'S WARRANTY RESPONSIBILITIES:

- As the off-road engine owner, you are responsible for the performance of the required maintenance listed in your owner's manual. FPT Industrial S.p.A. recommends that you retain all receipts covering maintenance on your off-road engine, but FPT Industrial S.p.A. cannot deny warranty solely for the lack of receipts or for your failure to ensure the performance of all scheduled maintenance.
- As the off-road engine owner, you should however be aware that FPT Industrial S.p.A. may deny you warranty coverage if your off-road engine or a part has failed due to abuse, neglect, improper maintenance or unapproved modifications.
- Your engine is designed to operate on ultra-low sulfur diesel fuel only. Use of any other fuel may result in your engine no longer operating in compliance with California's emissions requirements.
- You are responsible for initiating the warranty process. The ARB suggests that you present your off-road engine to a FPT Dealer as soon as a problem exists. The warranty repairs should be completed by the dealer as expeditiously as possible. If you have any questions regarding your warranty rights and responsibilities, you should contact North American FPT Technical Service Group at (833) 458-1378 or email: [fpt-na-warranty@fptindustrial.com](mailto:fpt-na-warranty@fptindustrial.com).

### CALIFORNIA EMISSION CONTROL WARRANTY PARTS LIST

#### Fuel injection system

- Fuel injection part
- Fuel injectors
- Fuel injection lines

#### Positive Crankcase Ventilation (PCA) system (if applicable)

- PCV valve
- Oil cap filler

#### Exhaust Gas Recirculation Systems (EGR)

- EGR valve assembly
- EGR Cooler

#### Exhaust after treatment devices (if applicable)

- Diesel Oxidation Catalyst (DOC)
- Diesel Particulate Filter (DPF)
- Selective Catalytic Reduction (SCR)
- Diesel Exhaust Fluid (DEF) tank and dispensing systems

#### Air induction system

- Intake manifold
- Turbocharger system (includes exhaust manifold)
- Charger air cooled

#### Cold Start Enrichment Systems

Electronic Control Units, Sensors, Solenoids, and Wiring harnesses used in above systems

Miscellaneous items used in above systems, such as hoses, belts, connectors, tubing, gaskets, and mounting hardware

Emission Control Information Labels

## REVALIDATION OF WARRANTY

### FOR LONG-TERM STORAGE OF ENGINES

These procedures are intended to prevent oxidation and/or fatigue of internal engine and fuel injection equipment components. If any engine has not been sold to the end user prior to nine (9) months after the manufactured build date of the engine, the seller must revalidate each engine at this time, and every twelve (12) months afterwards for a maximum of twenty-four (24) months for warranty coverage to be available, and provide written confirmation to WINCO inc that the engine was revalidated. Warranty will be exhausted if the unit is still in the seller's inventory after revalidation cycle.

1. Carefully inspect all external components for damage and/or corrosion
2. Rotate the engine approximately five (5) revolutions to prevent fatigue of internal engine components.
3. The engine must be protected from moisture intrusion and/or growth.
4. Circulate diesel fuel or fuel injection equipment calibration oil through the fuel injection equipment system components, and ensure the fuel system remains sealed to prevent evaporation and/or contamination.
5. Fill the cooling system with coolant. If not installed in an application, the cooling system connections at the thermostat housing and the water pump must remain dry and closed to limit environmental exposure and/or corrosion.
6. The engine must be pre-oiled before start-up (see lubrication section for lubrication specifications. This involves cranking the engine for one (1) minute at 10 second crank/10 second no crank intervals, while ensuring the engine will not start, in order to circulate oil throughout the lubrication and turbo systems without damaging the starter motor.
7. If the engine is installed in an application, "fogging" the engine is an acceptable method to protect the internal engine components by operating the engine for 15minutes at 500-800 RPM, and nebulize the following amounts of oil through the air intake system.

CAUTION: Exceeding the oil increments below may induce engine damage.

3-4 cylinder engines and per bank (8 cylinder engines)	60 grams
6 cylinder engines	120 grams
12 cylinder engines (per bank)	80 grams

Service records indicating the requirements are performed must be maintained. Failure to comply with these storage requirement procedures may revoke consignment privileges, and limit and/or void the applicable warranty on the engine.

## US ENVIRONMENTAL WARRANTY STATEMENT

FPT Industrial S.p.A. warrants to the ultimate purchaser and each subsequent purchaser that the engine is designed, built, and equipped so as to conform with US Environmental Protection Agency (EPA) regulations applicable at the time of manufacture and that it is free from defects in workmanship or material which would cause it not to meet these regulations for a period of time:

- 2 years or 1,500 hours of operation, whichever occurs first, for engines less than 19kW (25HP)
- 5 Years or 3,000 hours of operation, whichever occurs first, for engines greater than or equal to 19kW (25 HP)

Note: This warranty applies to all units operated in the United States and Canada.

### COVERAGE:

The model year, class of engine, and emission application determination for your engine are identified on the Emission Control Information Label. This label is affixed to one of the following areas of the engine: the top of the engine’s rocker arm cover, the right-hand side of the oil pan, and the right-hand side of the engine’s front gear cover. The warranty period begins on the date the new equipment is sold to the first retail purchaser. The presence of the emission control label is the indication that the engine conforms to the applicable standards. Any emission control system parts which are proven defective during normal use will be repaired or replaced during the warranty period.

The engine owner has responsibility to perform all the required maintenance listed in the Owner’s Manual. FPT Industrial S.p.A. will not deny an emission warranty claim solely because no record of maintenance exists; however, a claim may be denied if failure to perform maintenance resulted in the failure of the warranty part.

It is recommended that replacement parts used for maintenance or repairs be FPT Industrial S.p.A. service parts to maintain the quality originally designed into your emission certified engine. The use of non-FPT Industrial S.p.A. parts does not invalidate the warranty on other components unless the use of such parts causes damage to warranted parts.

The manufacturer is liable for damages to the other engine components caused by the failure of any warranted emission control system part. FPT Industrial S.p.A. is not responsible for failures resulting from improper repair or the use of parts that are not genuine FPT Industrial S.p.A. or FPT Industrial S.p.A. approved parts.

### COMPONENT COVERAGE:

New engines certified for sale and registered will have the following items covered by the emission warranty, depending on the emission level of the engine, if the items were first installed on the new engine as original equipment.

### EMISSION CONTROL WARRANTY PARTS LIST :

<ul style="list-style-type: none"> <li>Fuel injection system</li> <li>Fuel injection part</li> <li>Fuel injectors</li> <li>Fuel injection lines</li> </ul>	<ul style="list-style-type: none"> <li>Air induction system</li> <li>Intake manifold</li> <li>Turbocharger system (includes exhaust manifold)</li> <li>Charger air cooler</li> </ul>
<ul style="list-style-type: none"> <li>Positive Crankcase Ventilation (PCV) system (if applicable)</li> <li>PCV valve</li> <li>Oil cap filler</li> </ul>	<ul style="list-style-type: none"> <li>Exhaust after treatment devices (if applicable)</li> <li>Diesel Oxidation Catalyst (DOC)</li> <li>Diesel Particulate Filter (DPF)</li> <li>Selective Catalytic Reduction (SCR)</li> <li>Diesel Exhaust Fluid (DEF) tank and dispensing systems</li> </ul>

Cold Start Enrichment Systems

Electronic Control Units, Sensors, Solenoids, and Wiring harnesses used in above systems

Miscellaneous items used in above systems, such as hoses, belts, connectors, tubing, gaskets, and mounting hardware.

Emission Control Information Labels

# WARRANTY STATEMENT

---

WINCO Incorporated warrants to the original purchaser for the warranty period that goods manufactured or supplied by it will be free from defects in workmanship and material, provided such goods are installed operated and maintained in accordance with WINCO written instructions.

WINCO's sole liability, and Purchaser's sole remedy for a failure under this warranty, shall be limited to the repair of the product. At WINCO's option, material found to be defective in material or workmanship under normal use and service will be repaired or replaced. For warranty service, contact a Winco Authorized Service Center within the warranty period from date of purchase.

\*NOTE: Units that are resold by original owner are not covered under this warranty. Any further warranty, whether expressed or implied, rests solely with the reseller.

## THERE IS NO OTHER EXPRESS WARRANTY.

To the extent permitted by law, any and all warranties, including those of merchantability and fitness for a particular purpose, are limited to the warranty period from date of purchase. In no event is WINCO liable for incidental or consequential damages.

Note: Some states do not allow limitation on the duration of implied warranty and some states do not allow the exclusion or limitation of incidental or consequential damages, so the above limitations may not apply in every instance. This warranty gives you specific legal rights which may vary from state to state.

## WINCO, INC. WARRANTY EFFECTIVE DATE

Air cooled units purchased for stock have 1 year to be sold. The warranty to the original retail customer commences on the date of sale of the product to them. All liquid cooled units have 180 days from the Winco invoice to submit a start up date. If no startup form is submitted, then warranty period starts on the Winco invoice date unit was sold.

Date of sale is defined as the day the customer takes delivery of the product. This warranty shall remain in effect to the original purchaser for the period stated on the sales literature. The warranty is not transferable and the retail customer must retain his original bill of sale as proof of purchase date.

WINCO, Inc. agrees to the following obligations during the warranty period:

1. To warrant any defect in material or workmanship of products sold under the WINCO and DYNA brand names in accordance with the warranty statements in the operator's manuals.
2. To reimburse authorized WINCO, Inc. Service Centers/Dealers for the cost of parts plus standard ground UPS shipping charges for all valid warranty repairs and to reimburse same said service centers/dealers for reasonable labor charges based on WINCO's current warranty labor reimbursement rate.
3. To furnish its authorized service centers/dealers with the necessary parts to make the repairs. WINCO Generator Warranty Periods & Restrictions

## WINCO GENERATOR WARRANTY PERIODS & RESTRICTIONS

### Industrial Portables

WL Models - 3 Years, See Notes 1 & 2

W Models - 3 Years, See Notes 1, 2, & 5

DP Models - 3 Years, See Notes 1 & 2

HPS Models - 2 Years, Home Use ONLY; Commercial use\* is 90 Day Warranty, See Note 1

### EMERGEN-C (EC) Series

2 Years, See Note 1

### DE Series

1 Year/2000 hours, No Travel Time

Mobile Diesel Series

1 Year/2000 hours, No Travel Time

### PTO Series

15kW & 10kW - 1 Year, Limited Farm Standby Only

25kW thru 165kW - 3 Years, Limited Farm Standby Only/Commercial use\* 1 Year

### Two Bearing Series

1 Year, Bench Labor and Parts only

### Gaseous/Packaged Standby Series (PSS)

Air-Cooled Models (PSS8, PSS12, & PSS20) – 2 Years/2000 Hours Standby Only See Notes 3 & 4 Prime Power use 1 Year/2000 Hours See Notes 3 & 4

Liquid-Cooled Models (PSS21 - PSS150) - 2 Years/2000 Hours Standby Only See Notes 3 & 4 Prime Power use 1 Year/2000 Hours See Notes 3 & 4

### Diesel Standby Series (DR)

Liquid-Cooled Models (DR12 - DR600) - 2 Years/2000 Hours Standby Only See Notes 3 & 4

Prime Power use 1 Year/2000 Hours See Notes 3 & 4

Accessories (Installed on Generator or shipped loose)

1 Year from factory invoice or 2000 Hours (whichever occurs first)

## Automatic Transfer Switches (ATS)

See ATS Manufacturer's Warranty

### NOTES

Note 1: First 2 years of warranty coverage includes Parts and Bench Labor Only, no travel time or labor allowance for removal or reinstallation of the product from its application.

Note 2: 3rd Year warranty coverage is parts only/no labor.

Note 3: Round trip mileage is limited to 200 miles per trip and a total of 2 trips per repair unless authorized in writing by the WINCO Service Dept.

Note 4: Mileage allow on permanently installed units only. Trailer mount units is bench labor only.

Note 5: W3000 is a 1 Year Warranty.

\*Commercial use is defined as Construction, Rental, Prime Power, or use in a business of any type including agricultural and hobby. Prime Power use is defined as any application where the generator set is being used 'off-grid' where there is no utility power present. Standby use is defined as an application where utility power is present -and- the generator set is used as emergency backup during utility power outages.

WINCO reserves the right to change or improve it's products without incurring any obligations to make such changes or improvements on products purchased previously.

### EXCLUSIONS:

WINCO does not warrant Engines. Engines are covered exclusively by the warranties of their respective manufacturers.

WINCO does not warrant Batteries, or Other Component Parts that are warranted by their respective manufacturers.

WINCO does not warrant modifications or alterations which were not made by WINCO, Inc.

WINCO does not warrant products which have been subjected to misuse and/or negligence or have been involved in an accident.

This warranty does not include travel time, mileage, or labor for removal or reinstallation of WINCO product from its application, unless specifically authorized.

### WHAT IS COVERED BY WARRANTY

1. Generator end including rotor, stator, end brackets, and bearing.
2. Control box including transformers, circuit breakers, wiring, resistors, and switches.
3. LP/NG fuel system including fuel solenoid, demand regulator, carburetor, and hoses.
4. Cradle assembly including cradle, cross member, and shock mounts that fail. Shock mounts damaged from rough handling are not covered.
5. Reasonable travel time for the PSS & DR series generators only, that are permanently installed.
6. Ground shipping charges for warranty parts, no premium service, domestic US shipments only.

### WHAT IS NOT COVERED BY WARRANTY

1. Products which have been subjected to alteration, modification, neglect or unauthorized repairs not approved in writing by Winco, Inc.
2. Products no longer owned by the original purchaser.
3. Products with shipping or freight damage. File a freight claim with the delivery carrier.
4. Products suffering normal wear, accidents, improper maintenance or improper protection in storage. Products damaged by rough handling, such as shock mounts on cradle assemblies.
5. Pressure or steam cleaning of products, cleaning of fuel system, or flushing of cooling system.
6. Replacement of filter, belts, antifreeze, or lubricants.
7. Electrical items, such as light bulbs, receptacles, spark plugs, or any items damaged by welding or jump starting.
8. Any repeat or shop come-back repairs resulting from poor service work or improper diagnosis and testing. Replacement of parts as a trial-and-error method of diagnosis will not be considered for warranty.
9. Replacement parts other than those sold by Winco, Inc.
10. Damage caused by fire, flood, lightning or any other natural disaster.
11. Damage caused by improper protection during installation, (i.e. not protecting contactor in the ATS panel and getting wire trimming or debris from drilling the box in the contactor coil or contacts.)
12. Damage caused by over loading of the generator and failure to adequately provide overload protection.
13. LP/NG fuel adjustments or conversion from one fuel to another.
14. Adjustment of any kind, all units are 100% load tested before shipping.
15. Any damage caused by the use of the equipment for purposes other than for which it was designed.
16. Engines - All engines used by Winco, Inc. are warranted by their respective manufacturer's.
17. Batteries - Must be returned to original battery manufacturer.
18. Damage caused by improper installation or failure to provide adequate ventilation.
19. Cosmetic repairs, such as repainting.
20. Freight charges for transportation to and from a Warranty Service Center.
21. Rental costs of renting replacement generators.
22. Travel time or service calls unless specifically authorized by Winco, Inc. in writing.

### GENERAL INFORMATION

The WINCO, Inc. Service Department is open from 7:30 AM to 4:30 PM Central Standard time.

It is located at 225 South Cordova Ave., Le Center, MN, 56057-1805.

Phone Numbers: Service Department - 507-357-6831 FAX Line - 507-357-4857. Email address is service@wincogen.com

The phone number to for the General Switchboard/Sales Department is 507-357-6821.

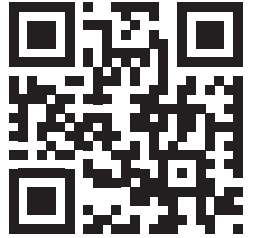

**WINCO<sup>®</sup>**  
**GENERATORS**



AN AMERICAN COMPANY

225 S. CORDOVA AVE • LE CENTER, MN 56057

Sales: 507-357-6821 • [sales@wincogen.com](mailto:sales@wincogen.com)

Service: 507-357-6831 • [service@wincogen.com](mailto:service@wincogen.com)

[www.wincogen.com](http://www.wincogen.com)

