

# **INSTALLATION AND OPERATORS MANUAL**

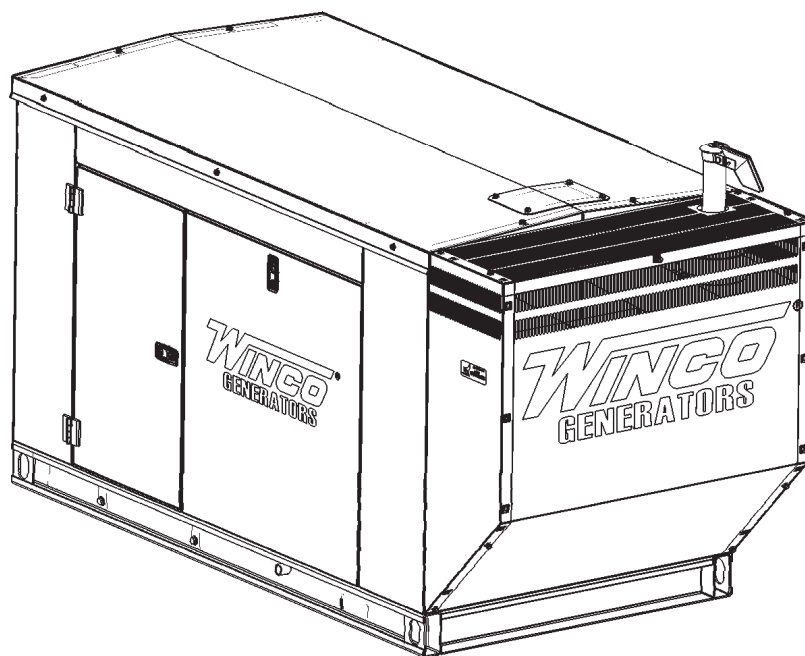

COPY YOUR MODEL AND SERIAL NUMBER HERE

No other WINCO generator has the same serial number as yours. If you should ever need to contact us on this unit, it will help us to respond to your needs faster.

MODEL \_\_\_\_\_

SERIAL NUMBER \_\_\_\_\_

PURCHASE DATE \_\_\_\_\_

DEALER NAME \_\_\_\_\_

DEALER PHONE # \_\_\_\_\_



# TABLE OF CONTENTS

<b>SAVE THESE INSTRUCTIONS</b>	<b>2</b>		
<b>SAFETY INFORMATION</b>	<b>3</b>		
SAFETY DEFINITIONS			
<b>SPECIFICATIONS</b>	<b>4</b>		
<b>DR1214</b>	<b>4</b>		
<b>INTRODUCTION</b>	<b>5</b>		
TESTING POLICY			
PRODUCT DESCRIPTION			
<b>PREPARING THE UNIT</b>	<b>6</b>		
START-UP CHECK LIST			
UNPACKING			
LIFTING THE GENERATOR SET			
<b>INSTALLATION</b>	<b>7</b>		
GENERAL INFORMATION			
VENTILATION REQUIREMENTS			
EXHAUST INSTALLATION			
FUEL INSTALLATION			
INSTALLING THE FUEL LINE			
ELECTRICAL CONNECTIONS			
GROUNDING			
INSTALLING THE BATTERY			
SERVICING BATTERIES			
BATTERY CHARGER & BLOCK HEATER			
TRANSFER SWITCH			
<b>AC WIRING</b>	<b>11</b>		
<b>DC WIRING</b>	<b>12</b>		
DC INTERCONNECTIONS TO THE ATS			
<b>STARTING PROCEDURE</b>	<b>14</b>		
PRE-START CHECK LIST			
LUBRICATION			
COOLANT			
		<b>CONTROL LAYOUT</b>	<b>15</b>
		MANUAL MODE	
		<b>AVR WIRING</b>	<b>16</b>
		AUTO MODE	
		CONTROL POWER	
		<b>OPERATING CONDITIONS</b>	<b>17</b>
		NORMAL OPERATION	
		HARSH ENVIRONMENTS OPERATIONS	
		COLD WEATHER OPERATIONS	
		<b>MAINTENANCE</b>	<b>18</b>
		CHANGING THE OIL	
		CHANGING OIL FILTER	
		FILLING COOLANT	
		CHANGING COOLANT	
		CLEANING RADIATOR	
		CHANGING AIR FILTER	
		DRAINING WATER SEPARATOR	
		CLEANING WATER SEPARATOR	
		ADJUSTING THE GOVERNOR	
		STORAGE	
		RETURNING ENGINE TO SERVICE	
		MAINTENANCE SCHEDULE	
		<b>TROUBLE SHOOTING TABLES</b>	<b>22</b>
		<b>WIRING SIZE TABLE</b>	<b>23</b>
		<b>WIRING DIAGRAMS</b>	<b>24</b>
		<b>DSE7310 WIRING DIAGRAM</b>	<b>25</b>
		<b>LIMITED WARRANTY</b>	<b>26</b>

## SAVE THESE INSTRUCTIONS

This manual contains important instructions that should be followed during installation and maintenance of the generator. Read and understand all instructions in the manual before starting and operating the generator.

### USING THIS MANUAL

Congratulations on your choice of a WINCO generator. You have selected a high-quality, precision-engineered generator designed and tested to give you years of satisfactory service.

To get the best performance from your new generator, it is important that you carefully read and follow the operating instructions in this manual.

Should you experience a problem please follow the "Troubleshooting Tables" near the end of this manual. The warranty listed in the manual describes what you can expect from WINCO should you need service assistance in the future.

# SAFETY INFORMATION

## IMPORTANT SAFETY INSTRUCTIONS

This engine generator set has been designed and manufactured to allow safe, reliable performance. Poor maintenance, improper or careless use can result in potentially deadly hazards; from electrical shock, exhaust gas asphyxiation, or fire. Please read all safety instructions carefully before installation or use. Keep these instructions handy for future reference. Take special note and follow all warnings on the unit labels and in the manuals.

## SAFETY DEFINITIONS

<b>DANGER</b>	Indicates an imminently hazardous situation which, if not avoided, will result in death or serious injury.
<b>WARNING</b>	Indicates a potentially hazardous situation which, if not avoided, could result in death or serious injury.
<b>CAUTION</b>	Indicates a potentially hazardous situation which, if not avoided, may result in minor or moderate injury. It may also be used to alert against unsafe practices.

## CALIFORNIA PROPOSITION 65



**WARNING:** This product contains crude oil, gasoline, diesel fuel and other petroleum products, Antifreeze to which can expose you to chemicals including toluene and benzene, Ethylene glycol (ingested) which are known to the State of California to cause cancer, birth defects or other reproductive harm and developmental issues. For more information go to [www.P65Warning.ca.gov](http://www.P65Warning.ca.gov).

## DANGER: ELECTRICAL SHOCK

The output voltage present in this equipment can cause fatal electric shock. This equipment must be operated by a responsible person.

- Do not allow anyone to operate the generator without proper instruction.
- Guard against electric shock.
- Avoid contact with live terminals or receptacles.
- Use extreme care if operating this unit in rain or snow.
- Use only three-pronged grounded receptacles and extension cords.
- Be sure the unit is properly grounded for your application.

## DANGER: DEADLY EXHAUST GAS

Exhaust fumes from any gasoline engine contain carbon monoxide, an invisible, odorless and deadly gas that must be mixed with fresh air.

- Operate only in well ventilated areas.
- Never operate indoors including attached garages
- Never operate the unit in such a way as to allow exhaust gases to seep back into closed rooms (i.e. through windows, walls, floors).

## WARNING: FIRE HAZARD

Gasoline and other fuels present a hazard of possible explosion and/or fire.

- Do not refuel when the engine is running or hot.
- Keep fuel containers out of reach of children.
- Do not smoke or use open flame near the generator set or fuel tank.
- Keep a fire extinguisher nearby and know its proper use. Fire extinguishers rated ABC by NFPA are appropriate.
- Store fuel only in an approved container, and only in a well ventilated area.
- Follow local codes for closeness to combustible material.

## CAUTION: PERSONAL INJURY

The muffler becomes very hot during operation and for a period after the unit has been turned off. Do not touch the muffler until it has completely cooled off.

## CAUTION: NOISE HAZARD

Excessive noise is not only tiring, but continual exposure can lead to loss of hearing.

- Use hearing protection when working around this equipment for long periods of time.
- Keep your neighbors in mind when using this equipment.

## CAUTION

Keep the generator and surrounding area clean.

- Remove all grease, ice, snow or materials that create slippery conditions around the unit.
- Remove any rags or other materials that could create a potential fire hazard.
- Carefully clean up any gas or oil spills before starting the unit.

## CAUTION

All service, including the installation or replacement of service parts, should be performed only by a qualified technician.

- Use only factory approved repair parts.
- Do not work on this equipment when fatigued.
- Never remove the protective guards, covers, or receptacle panels while the engine is running.
- Use extreme caution when working on electrical components. High output voltage from this equipment can cause serious injury or death.
- Always avoid hot mufflers, exhaust manifolds, and engine parts. They can cause severe burns instantly.
- The use of the engine-generator set must comply with all national, state, and local codes.

# SPECIFICATIONS

## DR1214

GENERATOR				
	DR1214-03	DR1214-04	DR1214-17	DR1214-18
STANDBY				
Watts	12,500	12,500	12,500	12,500
Volts	120/240	120/208	120/240	277/480
Phase	Single	Three	Three	Three
PF	1.0	0.8	0.8	0.8
Amps	52	43	37	18
Hertz	60	60	60	60
PRIME				
Watts	11,250	11,250	11,250	11,250
Volts	120/240	120/208	120/240	277/480
Phase	Single	Three	Three	Three
PF	1.0	0.8	0.8	0.8
Amps	47	39	34	16
Hertz	60	60	60	60

GENERATOR RESISTANCE (all value at 22°C)	
Model	
Single Phase	Stamford SOL1-S1
Three Phase	Stamford SOL1-P1
Winding Group	
Single Phase	706
Three Phase	711
Rotor	
Single Phase	0.524 Ω
Three Phase	0.509 Ω
Stator	
706	0.191 Ω per phase series star connected
711	0.641 Ω per phase series star connected
Exciter Rotor	0.101 Ω per phase
Exciter Stator	17.638 Ω

ENGINE	
Model	ISUZU 3CE1
Starting System	12 Volt
Fuel	ASTM D-975 - 1D OR 2D*
Oil Type	See Lubrication section in this manual
Oil Capacity	7 Quarts
Cooling System	50/50 mix

\* See engine manual for additional fuel types and specifications

# INTRODUCTION

## TESTING POLICY

Before any generator is shipped from the factory, it is fully checked for performance. The generator is loaded to its full capacity, and the voltage, current, and frequency are carefully checked.

Rated output of generator is based on engineering tests of typical units, and is subject to, and limited by, the temperature, altitude, fuel, and other conditions specified by the manufacturer of applicable engines.

This unit comes factory set for either key start or manual start. With the DSE 7310 MKII controller used in the manual start option it is possible to wire the control for remote start. Wiring instructions can be found further in this manual. The key start version does not have this option.

## PRODUCT DESCRIPTION

The engine-generator set consists of a multi-cylinder, liquid-cooled engine nominally operating at 1800 RPM. This generator set meets current EPA regulations for standby or prime power use. The generator frequency regulation is maintained by the engine mechanical governor to within +/- 2 Hertz. The generator is connected to the engine flywheel via flexible drive disks. The generator set is skid mounted with isolation mounts between the engine and base.

### NOTICE:

A Customer supplied 12 Volt battery is required to complete the installation. Battery requirements are listed later under the battery installation section.

The generator ships with an advanced DSE7310 digital controller. The DSE7310 will electronically display useful engine and generator performance information. The controller starts and stops the generator and monitors critical operating parameters and will shut the generator down to protect the engine from damage.

### GENERATOR SET:

Every WINCO generator set has its own unique identity data plate. This data plate identifies the complete unit model number, the system serial number, and has links to the individual components that form the generator set in our factory records. Several of the major components also have their own individual data plates providing additional information to document build data for warranty and replacements parts. Be sure to have the main WINCO unit data plate information recorded inside the front cover of this manual for future reference and for identification whenever requesting field or factory assistance.

**Primary fields needed for assistance are complete model number and serial number.**

### ENGINE:

This manual covers specific operation of the combined engine generator set. The basic engine information provided in this manual is not suitable for all operating conditions. Refer to the engine operators manual for more detailed operation and maintenance information.

### CAUTION: EQUIPMENT DAMAGE:

Be sure to check the engine oil level frequently as specified in the engine manual.

The engine manufacturer has established an excellent worldwide engine service organization; engine service is available from a nearby authorized dealer or distributor.

The rated power of each engine-generator is limited by the temperature, altitude, and all other ambient conditions specified by the engine manufacturer.

### Derates

Above Sea Level 5,500 FT	20%
-----------------------------	-----

Units should not be operated in ambient temperature greater than 120° Fahrenheit.

### GENERATOR:

The nameplate includes a standby and prime/continuous rating. The standby rating is the maximum amount of power the generator set can produce. For prime power applications the load should be equal to or less than the prime power rating and the load is assumed to be variable. It is acceptable to occasionally reach the standby rating during prime operation to start motors or other temporary surges.

WINCO generator sets use a brushless, AVR (Auto-Voltage Regulator) controlled broad-range generator ends. The generator converts rotational mechanical energy into electrical energy. These WINCO units are equipped with generators manufactured by Cummins Generator Technologies. Each generator 'end' has its own data tag. A unique serial number is on the data plate and the data label is affixed to the main frame on the generator on the left side.

# PREPARING THE UNIT

## START-UP CHECK LIST

A Start-Up Completion & Warranty Validation Form was sent along with this manual. This must be completed and returned to WINCO Inc. within 180 days of the factory invoice date.

If this form is not returned, the Warranty may be voided.

## UNPACKING

1. As you receive your unit, it is critical to check it for any damage. If any damage is noted, it is always easiest to refuse the shipment and let WINCO take care of the freight claim. If you sign for the unit, the transfer of the ownership requires that you file the freight claim
2. Before proceeding with the preparations of your new generator for operation, take a couple of minutes to ensure the unit you have received is the correct model and review the specification pages in this manual to ensure that this unit meets your job requirements.

### CAUTION: EQUIPMENT DAMAGE:

These units are shipped with oil and a 50/50 mix of coolant. Be sure to check all fluid levels before operating. See engine manufacturer's instruction manual for recommended oil requirements before initial starting.

Once generator set is on-site:

1. Carefully remove the crate.
2. After inspecting the engine-generator for external, physical damage, locate and check the following items packed with the unit:
  - a. Installation and Operator's Manual.
  - b. Engine manufacturer's instruction manual.
  - c. Start-up and warranty validation form.
  - d. Battery hold-down brackets & hardware.
  - e. Unit components or accessory items shipped loose for on-site installation.
  - f. Optional accessories.
3. Remove main frame hold-down bolts.
4. Unit can now be lifted from shipping rails.

## LIFTING THE GENERATOR SET

### NOTICE: PERSONAL INJURY:

To prevent injury to persons or equipment, observe the following guidelines when lifting the generator:

Due to the different designs, configurations, options, weights, site conditions, and available material handling equipment, specific lifting instructions are not provided for each individual generator set model. General guidelines provided are applicable to the entire generator line. It is the responsibility of the installing party to follow the lifting equipment's operator's manual to prevent injury to personnel and damage to the generator.

Smaller generator sets may not require use of overhead lifting equipment and may be placed on the pad with basic material handling equipment, i.e. a forklift. Always use

forklifts of a proper rating and with long enough forks to move the generator. As the distance from the forklift mast increases the lifting capacity for the forklift decreases. When lifting from the side the forks should extend the entire width of the unit to the opposite side frame rail.

### CAUTION:

Do not attempt to lift the generator set by the means of the lifting eyes on the engine or generator end. These lifting points are only for the use during the manufacturing process and are designed for lifting of the individual generator set components and not the complete unit.

### WARNING:

NEVER attempt to lift the fuel tank filled with fuel. Sloshing of the fuel can cause a shift in the balance of the fuel tank, making for a DANGEROUS, unbalanced lifting load. If the generator was shipped on the fuel tank, use the lifting points located on the fuel tank to move the entire generator set into place. DO NOT PLACE FUEL IN THE TANK PRIOR TO LIFTING.

# INSTALLATION

The max continuous coolant temperature for this unit is 113°F. This unit should be installed in a well ventilated area, ensuring the exhaust air cannot be recirculated back into the engine.

## CAUTION:

This unit will get hot while it is running and for some time afterward.

## WARNING: PERSONAL INJURY:

Before proceeding with the installation, be sure the engine control is in the "stop" position and the emergency stop depressed. Also, be sure the generator MLCB (main line circuit breaker) is in the "off" position and the unit starting battery is disconnected.

## GENERAL INFORMATION

Before beginning the installation process, recheck the voltage, phase, and amperage rating of the generator set. Be certain it can handle the intended load and are compatible with the intended loads. Plans for installation should be prepared with proper attention to mechanical and electrical engineering detail to assure a satisfactory system installation. The installation must comply with all national, state, and local codes.

The information in this manual is offered only as a guide to finalizing your installation plans and does not substitute for sound engineering judgment for the specific application.

## NOTICE

For full service switching of the entire load, the ATS must be 'SE' (Service Entrance) rated or must have a properly rated fusible disconnect installed before the ATS to protect the contacts.

## ENGINE GENERATOR SET MOUNTING

This engine-generator set is generally supplied as weather enclosed packages for quick installation on an outdoor concrete pad. They are also available as open skid mounted units for indoor installation in a building or protective enclosure, properly ventilated, supplied by the installer.

The factory weather enclosures are acoustical housing intended for outdoor installation only. Factory weather enclosed units are not intended to be used indoors and no support is available to assist in re-engineering finished packaged units. The unit should be mounted to allow ample working room around it. A general rule to follow is to allow 24 inches or more of clearance for maintenance. Follow local codes for clearance from combustible surfaces.

The unit's main frame must be bolted securely to a solid base. The engine-generator is mounted on channels which are attached with special shock mounts to the main frame. This allows the engine-generator free movement without affecting the base or surrounding equipment.

## WARNING: EQUIPMENT DAMAGE:

Never mount these engine-generator sets to a wooden base/structure. Over time, the wood will deteriorate and the unit mountings will come loose. These units must be mounted to a steel or concrete base.

## VENTILATION REQUIREMENTS

### OPEN SKID

## WARNING: EQUIPMENT DAMAGE:

It is the installer's responsibility to ensure that there is sufficient cooling air available to prevent the engine and generator from over heating. Damage caused by overheating is not covered by warranty.

Providing proper air movement during your installation planning is essential. You will need to provide a fresh air inlet as well as a hot air outlet (to the outside of protection housing) for proper engine performance. These engine-generator sets are equipped with unit mount radiators and the engine is equipped with a pusher type fan. The hot air from the face of the radiator must be ducted out of the enclosure to ensure proper cooling. Failing to do so will allow the hot air to recirculate around the radiator causing the engine to overheat, resulting in an engine shutdown and damage. If louvers are used in front of the hot air duct to protect the unit from outside weather, the louvers should be 1½ times as large as the area of the radiator face to prevent back pressure.

Foam or other seals can be used to form a tight lip forcing all of the air from the engine fan out of the enclosure. In addition to a hot air discharge, you must plan a fresh air intake opposite the radiator discharge. Their fresh air inlets should be 1½ to 2 times larger than the radiator face. The extra air inlet area is required to minimize restriction and to provide combustion air for the engine. Do not block fresh air intakes with other equipment as this will result in insufficient air flow to the engine for cooling. Installing them opposite the hot air discharge will allow a sweeping flow of cooling air across the engine, preventing hot spots.

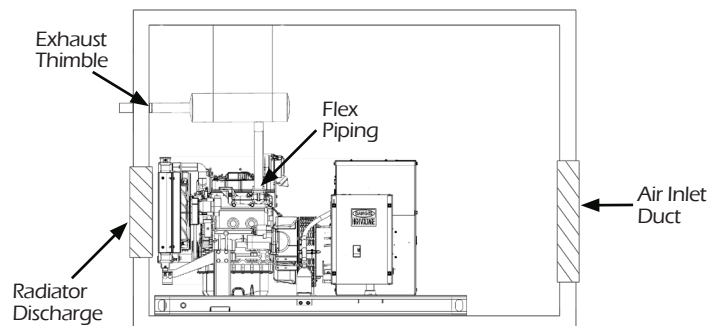

The WINCO installation manual OPM-112 contains additional information on indoor, open skid installations and is available electronically through our website or by requesting a copy from the factory.

## EXHAUST INSTALLATION

### WARNING: PERSONAL INJURY

Improper exhaust installation will allow dangerous gases to seep into enclosed spaces causing a hazard to your health and/or death.

All exhaust must be piped out of the enclosure. When selecting a location to exhaust fumes make sure that the potential for contact with people is controlled. Exhaust can enter buildings through windows, ventilation systems and other openings if proper precautions are not followed.

The exhaust must be isolated from the vibration of the engine. If the exhaust is connected in a rigid system it will result in damage to the engine. The generator comes equipped with an engine mounted flex pipe to aid your installation. Ensure proper alignment with the generator. The flex can be eliminated if it is pushed to one side to make a connection.

The most direct path possible should be used to get to the outside of the enclosure. Each bend restricts the pipe and increases back pressure. It may be necessary to increase the exhaust pipe diameter in some applications.

The exhaust pipe is very hot. When passing through the structure it is critical that a thimble or other appropriate technique is used to dissipate the heat and prevent the structure from catching on fire.

It is preferable to exhaust out the side of the enclosures. Slope the pipe slightly downward away from the engine to cause any water in the exhaust to run away from the engine. Do not exhaust near intake. Once outside the enclosure a rain cap or other technique must be used to keep water out of the exhaust. In mobile applications make sure the rain flap faces to the rear of the vehicle so that it is not blown open during transportation.

The generator ships with a critical grade muffler that should be installed to decrease noise. It can be mounted either internally or externally to the enclosure. The muffler cannot increase back pressure to more than 0.725 psi.

## FUEL INSTALLATION

The fuel supply should be as close to the engine as possible. This will reduce the installation cost of fuel runs and minimize line losses. The diesel fuel supply should be no more than 3 feet below the fuel inlet pump. If your fuel supply is lower than 3 feet, you may have to install an additional lift pump to bring the fuel up to the mechanical fuel pump on the engine.

### WARNING: FIRE HAZARD

All fuel runs should be installed by a licensed fuel supplier.

The information in this manual is offered to assist you in providing the proper fuel for your engine. However, this information is only provided to inform you of the engine's requirements and assist you aware of the decisions you must make. In no case should the instructions or information provided be interpreted to conflict with any local, state, or national codes. If in doubt, always consult your local fire marshal or fuel supplier.

OPM-189/A

## INSTALLING THE FUEL LINE

Engine-generator sets are properly adjusted before they leave the factory. Connecting a fuel supply with adequate supply volume is critical to reliable operation. Diesel units with optional base mounted fuel tanks are pre-plumbed to the fuel pump on the engine.

Open skid mounted diesel units are often supplied with capped inlet and return lines. The use of a suitable customer supplied flexible fuel lines is essential between the engine and fuel supply to provide a vibration break between your fuel supply and the engine.

### WARNING: FIRE DANGER:

Connecting rigid fuel line (i.e. steel or copper line) directly to the inlet fuel filter or fuel pump may cause the fuel line to crack during operation creating a serious fire hazard.

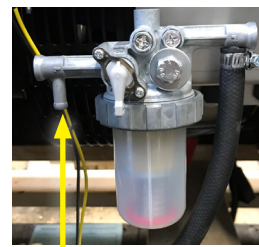

Fuel Inlet  
Connection

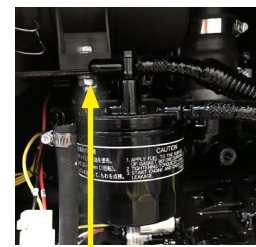

Fuel Return  
Line Connection

## ELECTRICAL CONNECTIONS

NOTICE: CLASS 1 WIRING METHODS ARE TO BE USED FOR ALL FIELD WIRING CONNECTIONS TO TERMINALS OF A CLASS 2 CIRCUIT

NOTE: The symbol  $\equiv$  always indicates ground where shown. All wiring must be completed in accordance with the National Electric Code as well as any state and local codes.

You must pay particular attention to wire size requirement for the amperage of service you are dealing with. The table below provides you guidance on wire sizing based on both wire type and amperage. Wire amperages have been derated for 40° C ambient temperatures operation.

## GROUNDING

Proper grounding of your generator is application dependent. Carefully evaluate your planned use of your generator to understand which grounding you require. If you are not sure what to do, contact a competent professional to assist you. The NFPA 70 250:34-35 are good technical references.

## NEUTRAL CONFIGURATION

This Winco generator ships with either a bonded or floating neutral depending upon the configuration. The distribution panel will be labeled indicating the configuration. A competent electrician or other professional should be consulted on the proper neutral configuration for the specific application. Generally a floating neutral is used



when the generator is connected to a buildings electrical system as a back up. Mobile or remote applications often require a bonded neutral. If the neutral configuration is changed in the field be sure to relabel the panel to its current condition.

## INSTALLING THE BATTERY

### CAUTION:

In the following battery installation procedure, check to be sure the engine control is in the “stop” position. This should be your last step before initial start-up.

A customer supplied 12 Volt battery is required to complete the installation. Installation of the highest CCA rated battery, within the correct BCI group, will increase cold weather starting performance.

### BATTERY REQUIREMENTS

Model	Voltage	BCI Group	Min. CCA Rating
DR12I4	12	24	650

### WARNING: EQUIPMENT DAMAGE:

This unit is 12 Volt and is negative ground. Permanent damage will occur if they are connected to a 24 Volt system or a positive ground system. If you are using the truck batteries to start these units, you may have to disable the charging system to keep it from interfering with the vehicle charging system.

Installation and servicing of batteries must only be preformed or supervised by personnel knowledgeable of batteries and the required precautions. Keep unauthorized personnel away from batteries.

When installing or replacing batteries, use the proper group/size starting battery. The battery should be a maintenance-free lead acid design. Deep cycle batteries will not work for this application.

### CAUTION: PERSONAL DANGER:

NEVER dispose a battery in a fire. The battery is capable of exploding.  
DO NOT open or mutilate the battery. Released electrolyte is known to be harmful to the skin and eyes and to be very toxic.  
These engine-generator sets are all NEGATIVE ground. Be very careful not to connect the battery in reverse polarity, as this may short circuit the battery charging system on the engine.

### CAUTION:

A battery presents a risk of electrical shock and high short circuit current. The following precautions must be observed when working with batteries:

1. Remove watches, rings, and other metal objects.
2. Use tools with insulated handles.
3. Check both the battery cable ends and the battery posts to be sure they are free of corrosion.
4. Always connect the battery positive cable first and then connect the battery negative cable. When removing the battery cables from the battery, reverse the procedure, disconnect the negative first and then the positive cable.
5. Be sure all connections are tight and coat the terminals and cable ends with dielectric grease.

### WARNING:

The electrolyte is diluted sulfuric acid that is harmful to the skin and eyes. It is electrically conductive and corrosive. The following precautions must always be taken.

1. Always wear full eye protection and protective clothing.
2. Where electrolyte contacts skin, wash off immediately with water.
3. If electrolyte contacts the eyes, flush thoroughly and immediately with water and seek immediate medical attention
4. Spilled electrolyte is to be washed down with an acid neutralizing agent. A common practice is to use a solution of one pound of bicarbonate of soda (baking soda) to one gallon of water. The bicarbonate of soda solution is to be added until the evidence of reaction (foaming) has ceased. The resulting liquid is to be flushed with water and the area dried.

### DANGER: EXPLOSIVE FIRE RISK:

1. Never smoke when near batteries.
2. Do not cause a flame or spark in the battery area.
3. Always discharge static electricity from your body before touching batteries by first touching a ground metal surface.

## SERVICING BATTERIES

Batteries used on these units may, over time, lose water. This is especially true if you are using a trickle charger to maintain your battery. When refilling the battery with water, use only distilled water. Tap water will shorten the service life of the battery.

Never fill the battery above the fill line. Over filling above the upper level line may cause the electrolyte to overflow, resulting in corrosion to the engine or nearby parts. Immediately wash off any spilled electrolyte following the procedure above.

NOTE: Always make sure that a new battery is fully charged before installing it on a generator set. Failure to do so can cause damage to the engine control module in the generator set.

All connections must be clean and tight. Check the electrolyte in the battery periodically to be sure it is above the plates. Never allow the battery to remain in a discharged condition.

#### **CAUTION: EQUIPMENT DAMAGE**

Never attempt to jump start this engine. If the battery should accidentally become discharged, disconnect the battery cables and recharge the battery before attempting to start the unit. Boost/jump starting this unit improperly will result in PERMANENT DAMAGE TO THE ENGINE CONTROL MODULE (ECM).

## **BATTERY CHARGER & BLOCK HEATER**

### **BATTERY CHARGER**

A three-stage, on-board marine battery charger is provided standard on this unit. The charger is a 5 amp dual use maintainer and charger designed to keep your batteries fully charged by maintaining them automatically. Make sure all DC battery connections are tight and clean. Follow battery manufacturer's recommendations. This charger is mounted under the customer connection on the control side of the generator. The charger will need to be plugged to a customer's power source, using a customer supplied heavy duty, UL approved extension cord. The receptacle is to be powered by a GFCI circuit and installed in accordance to the US National Electric Code. It is suggested that this circuit be fused to 20 Amps.

#### **Low/Charge Mode:**

The illuminated blue power LED and red low/charging LED. This indicates the Low/Charge mode is in process. When completed the RED Low/Charge LED will turn off.

#### **Auto Maintain Mode:**

The illuminated Green auto maintain LED. This indicates your 12 volt battery is fully charged. During short or long term storage periods, Auto Maintain (Energy Saver) mode will monitor and auto maintain a battery only when needed to maintain a full state of charge. This feature significantly reduces AC Power consumption, lowers operating costs and maximizes reserve power performance.

### **BLOCK HEATER**

The block heater on this unit is a 1000 watt heater and can use the same 20 Amp GFCI fused circuit. This circuit will terminate on the 120 Volt terminal block mount in the customer connection cabinet. The engine block heater installed on this unit should also be plugged into this receptacle. The block heater is thermostatically controlled when plugged in will maintain the engine coolant temperature between 100 and 120 degrees F.

## **TRANSFER SWITCH**

#### **NOTICE:**

For full service switching of the entire load, the ATS must be 'SE' (Service Entrance) rated or must have a properly rated fusible disconnect installed before the ATS to protect the contacts.

#### **WARNING: FIRE HAZARD:**

All wiring must be done by a licensed electrician, and must conform to the National Electrical Code and comply with all the local codes and regulations. Check with the local authorities before proceeding.

#### **INSTALLATION NOTES:**

Because of many different types of service, feeder and distribution equipment, no specific wiring instructions can be provided. It is recommended that only copper wire be used. In all cases it is essential that while the load is connected to the generator, there can be absolutely no feedback from the generator to the power line or the power line to the generator. When properly installed, the normal ATS Control and safety system will eliminate all paths and feedback.

To wire the automatic transfer switch into existing wiring, first determine which circuits will be on the emergency load circuit. If the entire load is transferred, the transfer switch can be wired directly after the meter and the service entrance, providing the service entrance ampere rating is within the transfer switch's rated capability.

If only specific circuits are to be powered under emergency power failure conditions, an additional distribution panel designated "emergency distribution panel" must be installed.

All selected emergency circuits are removed from main distribution panels and installed in the emergency distribution panel. The ATS is then installed between the main panel and the emergency distribution panel. Suggested circuits: freezer, refrigerator, furnace, emergency lights, sump pump, emergency outlet circuits, etc. Total running load must not exceed generator rating.

# AC WIRING

## WARNING

Make sure the generator is disconnected from the battery to prevent accidental starting.

## WARNING

Wiring and connections to unit should be performed by a competent technician. Improper installation could result in electrocution, which could cause equipment damage, serious injury or death.

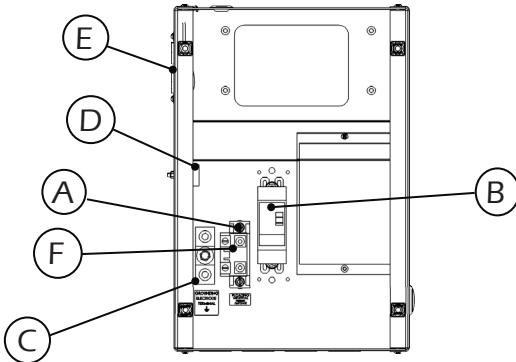

### A. NEUTRAL LUGS:

These lugs are isolated from ground and provided for you to connect your neutral wire from the transfer switch to the generator.

The 100 Amp terminal block lugs will handle wire sizes #4 to 300 MCM and should be torqued to 75in. lbs.

### B. GENERATOR CIRCUIT BREAKER:

This circuit breaker provides overload protection for the generator. Your power feeds from the transfer switch will connect the bottom lugs on the circuit breaker. The generator power feeds have already been wired into the upper lugs.

Please refer to the circuit breaker installed on your unit for breaker lug capacities and proper torque specifications.

Refer to Wire Sizing Table for guidance on wire sizing based on both wire type and amperage. For additional information on wire sizes, refer to table 310-16 of the National Electrical Code ANSI/NFPA 70.

### C. GROUND LUG:

These ground lugs are bonded to ground and are provided for you to connect your ground wire from the transfer switch to the lugs and will accommodate #10 AWG to 2/0 AWG and should be torqued to 200 in. lbs.

### D: 120V GFCI CIRCUIT TERMINAL BLOCK:

These terminals are rated for 20 Amps and will handle wire sizes #4 AWG to 18AWG. They should be torqued to 16 in. lbs. This circuit must be fed from a fused circuit in the distribution panel and it provides power for the block heater and the battery charger.

### E: 120V/20 AMP DUPLEX RECEPTACLE:

This convenience receptacle is used to power both battery charger and block heater. This circuit must be fed from a GFCI fused circuit in the distribution panel.

### F: NEUTRAL TO GROUND LEAD LUG:

This lug is provided on the neutral terminal block to allow you to run a neutral to ground lead if you are using the generator in a stand alone application. This would be an application where there is not a distribution panel and no other ground to neutral bond in the wiring system. If a grounding wire is attached here, remove the floating neutral label in the panel. This will not be used when you are wiring a generator and transfer switch into an existing power system.

## WARNING:

A mainline circuit breaker has been provided inside the generator housing. During all wiring installations, make sure the breaker is in the OFF position and the generator operating switch is in the OFF position.

## WARNING: EQUIPMENT DAMAGE:

When installing a three-phase 240 Volt system, be sure you know which lead is the high voltage "wild" leg (208 Volt line to neutral). The generator normally carries the high voltage on the G2 lead.

All wires should be installed in rigid or flexible conduit (knockouts are provided in the control box).

# DC WIRING

All communication and DC wiring should be run in separate conduit from AC wiring.

To install the wires, reference the following picture. Use a small flat head screwdriver to push the release spring inside the square hole (A). While the release is being pushed, insert the wire into the larger circular hole (B). Remove the screwdriver to secure the wire into place.

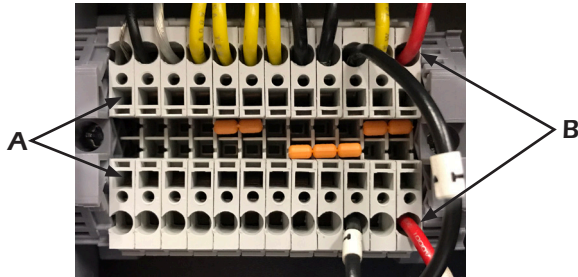

## REMOTE START

The DSE7310 is able to start the generator when it receives a remote signal from any dry contact. This makes the system compatible with a wide range of control mechanisms including two-wire start automatic transfer switches. When the contact closes the controller will automatically start. When the contact is opened the generator will go through a cool-down cycle and turn off. Connect the remote start leads to the Remote Start + and Remote Start - terminal blocks in the door behind the DSE 7310 controller.

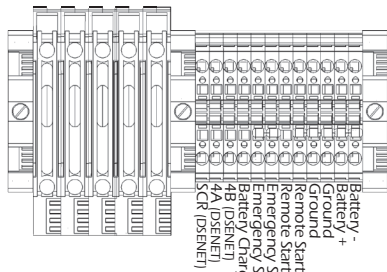

Two-Wire Start Hook-Ups

## E STOPS

In some applications additional emergency stops may be desired or necessary. The controller has terminals designed allowing the addition of multiple remote emergency stops. E-stops must be normally closed to work properly in this system. The e-stop circuit supplies power to the fuel solenoid and the starter circuit. Opening any switch in the series prevents the engine from cranking or from receiving fuel to run.

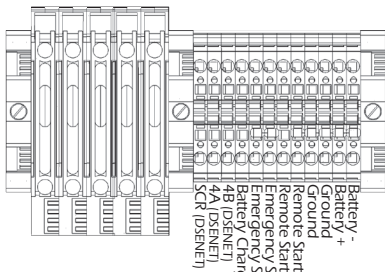

E-Stops

To wire additional emergency stop switches first remove the orange jumper between the two Emergency Stop terminal blocks. Failure to remove the jumper will prevent the remote switches from working properly. Add wires between the terminal block to the new switch(s). The switches must be wired in series for proper function. Test each e-stop after wiring to ensure they function properly.

## SERIAL COMMUNICATION

DSE provides a series of remote accessories that can help provide useful information to operators. These accessories communicate over the DSE Net. Terminal blocks are wired to the distribution panel to aid in installation. Follow the instructions included with each accessory.

The generator controller can communicate with a variety of controls and monitoring systems, including RS232 and RS485. The ports are wired onto the back of the DSE7310. In order to finalize communication the program will need to be adjusted using the free DSE configuration software to enable the communication. Contact Winco service for a list of register values.

## DC INTERCONNECTIONS TO THE ATS

### WARNING

Use a properly installed transfer switches when isolating the generator set from utility power. Failure to do so could result in backfeeding, which is illegal and dangerous. Backfeeding cause serious injury or death.

### WARNING

Be sure Engine/Generator is in the OFF position before you make any DC interconnections.

### CAUTION

Never run the AC and DC wiring in the same conduit.

## ASCO 185 UL SWITCH

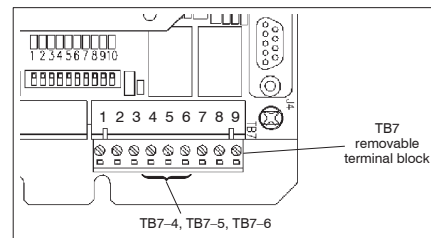

TB7 Generator starting contact terminals

Table A. Generator Start Connections

When the Utility fails	Terminals on Controller
contact closes	TB7-4 and TB7-5
contact opens	TB7-5 and TB7-6

## ASCO 300 UL SWITCH

When Normal Source Fails	Terminals On Transfer Switch
Contact Closes	TB1 and TB2
Contact Opens	TB1 and TB3

Engine start and auxiliary circuit terminal block TB located on 3ATS & 3NTS transfer switch.

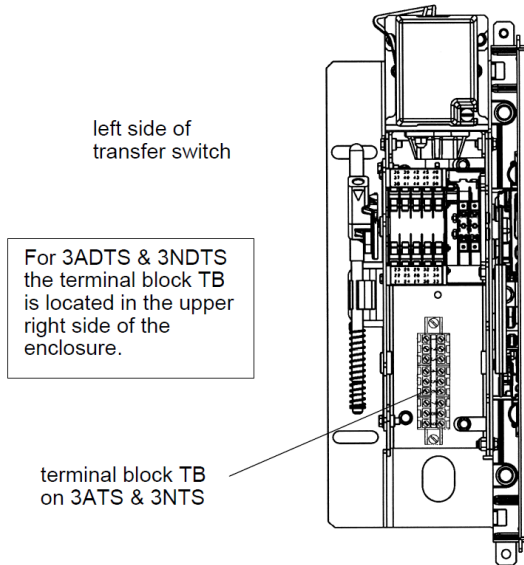

# STARTING PROCEDURE

## PRE-START CHECK LIST

There is a Pre-Start & Warranty Form that must be filled out by an Authorized WINCO Service Center. After completing the checklist, the engine-generator set is ready for initial start-up.

### WARNING: EQUIPMENT DAMAGE:

Before attempting to start this unit, complete your pre-start checklist and ensure the generator mainline circuit breaker (if installed) is in the proper position prior to starting. Starting this unit without it properly connected can cause serious personal injury or equipment damage.

DO NOT jump start these engine-generator sets. Starting these units on a low battery or jump starting them will cause damage to the engine control module.

### CAUTION:

For the first 10 seconds of operation all of the oil, coolant, and electrical shutdowns are disabled. This is enough time to cause catastrophic damage to the equipment if the pre-start checklist is not properly completed and proper maintenance isn't consistently followed.

## LUBRICATION

Before starting the engine, check the oil level in the crankcase. If it is low, refill to the full mark with the proper weight/grade of oil as recommended by the engine manufacturer's maintenance instructions. The necessity of using the correct oil, and keeping the crankcase full, cannot be over emphasized. Failure to use the proper oil and keep the crankcase properly filled will cause excessive engine wear and shorten its useful life.

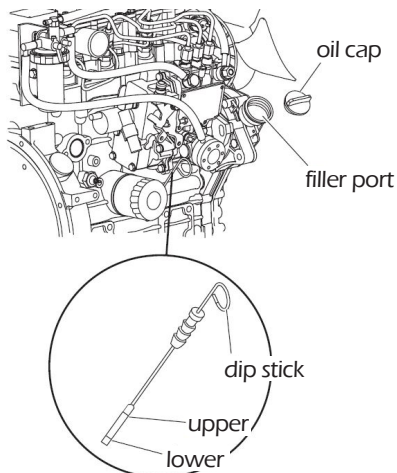

WINCO recommends our 5W-30 fully synthetic heavy duty engine oil to give you maximum cold weather protection while maintaining excellent performance in warmer weather. We have partnered with a national lubrication oil manufacturer to give you access to Winco private branded premium oil available at comparable prices to conventional oils. See your dealer for additional information.

### CAUTION: PERSONAL INJURY

Only check oil when the engine is not running and is at a low temperature in order to avoid the risk of burns.





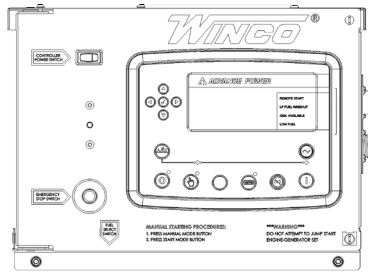

1. Remove the dipstick and ensure the oil level is between the Min and Max limits.
2. If it is difficult to assess the level of the oil, clean the dipstick using a clean cloth and then put it back into its seat. Remove the dipstick again and check the level.
3. If level is low, unscrew the oil cap and refill with suitable oil using the previous table.

## COOLANT

Before starting the engine, check the coolant level in the radiator. If it is low, refer to Refilling Coolant in the Maintenance section of this manual. The radiator should be filled to about 1 inch below the filler neck. For additional information on engine coolant requirements, see engine manufacturer's maintenance instructions.

# CONTROL LAYOUT



	<p><b>STOP/RESET</b> - This button places the module into its Stop/Reset mode. This will clear any alarm conditions for which the triggering criteria have been removed. The fuel supply de-energizes and the engine comes to a standstill. Should a remote start signal be present while operating in this mode, a remote start <b>WILL NOT</b> occur.</p>
	<p><b>MANUAL MODE</b> - This button places the module into its Manual Mode. Once in Manual Mode, the model responds to the Start button to start the generator and run it off load.</p>
	<p><b>START</b> - Pressing this button from STOP/RESET will start the engine and run the load.</p>
	<p><b>AUTO MODE</b> - This button places the module into its Auto Mode. This mode allows the module to control the function of the generator automatically.</p>
	<p><b>ALARM/LAMP TEST</b> - This button silences the audible alarm in the controller, deactivates the Audible Alarm output (if configured) and illuminates all of the LEDs on the module's face as a lamp test function.</p>
	<p><b>MENU NAVIGATION</b> - Used for navigating the instrumentation, event log, and configuration screens.</p>
	<p>A small rocker switch is located on the underside of the engine control cabinet.</p> <p>On gaseous models, the engine timing is controlled by the ECU on the engine and you need to tell it what fuel you want to operate on; LP or NG.</p> <p>On diesel models, this switch has been disconnected and will do nothing.</p>

## PROTECTIONS

When an alarm is present, the common alarm LED, if configured, will illuminate. The LCD display will show an icon to indicate the failure.

## WARNINGS

Warnings are non-critical alarm conditions. They do not affect the operation of the generator system, they serve to draw the operator's attention to an undesirable condition. Warning alarms are self-resetting when the fault condition is removed. The icon will appear steady in the display.

## SHUTDOWN

Shutdowns are critical alarm conditions that stop the engine and draw the operator's attention to an undesirable condition. Shutdown alarms are latching. The fault must be removed and the STOP/RESET button pressed to reset the module. The icon will be flashing in the display.

## MANUAL MODE

1. Press and release the Manual Mode button. The small LED light next to it should come on.
2. Press and release the green START ENGINE button. The DSE 7310 will send two signals to the engine. The first signal wire #21 will engage the fuel solenoid, the second wire, #22, will engage the starter on the engine. At this point the DSE 7310 will start the cranking cycle (10 seconds on and 10 seconds off).

**Note:** Wire #93 is energized to turn on the glow plugs for 15 seconds first and then the starter and fuel solenoid are engaged.

If the engine fails to start during this cranking period, the starter motor is disengaged and goes into a rest mode after which a second attempt is made to start the engine. Should this sequence continue through 3 cranking cycles the start sequence will be stopped and the display will show 'FAILED TO START'.

3. During manual operation, the load will not normally be applied to the generator. But caution must be used, if the line power should fail or be turned off the transfer switch during manual operation the load may be applied to the generator.

With the engine running smoothly check the no load voltage and frequency on the digital display. The voltage should match the nameplate and a frequency of 59.5 to 60.5 hertz (Hz).

If you have the proper voltage at the generator the next step is to check the voltage at the generator terminals in the Automatic Transfer Switch. The voltage between the G1 and the G3 terminals should be the same as it was on the generator front panel. The voltage should also be checked between the hot terminals (G1 and G3) and the G-N to be certain of a balanced voltage output and a solid neutral connection. The voltage between G1 and G-N should be about 120 volts AC (277 on 480 units). The same approximate voltage should be found between terminals G3 and G-N (120 volts AC).

On three phase panels the G2 voltage level should also be checked. ON 240 VOLT (DELTA) SYSTEMS BE SURE YOU KNOW WHERE THE HIGH VOLTAGE "WILD" LEG IS. IT MUST BE IN THE SAME LOCATION ON THE LINE SIDE AS IT IS ON THE GENERATOR SIDE. (i.e. if it's on L-3 on the line side it must be on G-3 on the generator side. Also on three phase systems make sure that the rotation is the same on the generator as it is on your line power. Failure to insure proper rotation will cause three phase motors to

spin backwards possibly damaging them.

**NOTICE:**

If for any reason during the check out procedure the voltage and frequency are not correct, depress the STOP/RESET button and correct the trouble before proceeding.

4. Stopping - There are two ways to stop the unit when it is in the manual mode. Pressing the STOP/RESET button will stop the unit immediately. Pressing the AUTO mode button will stop the unit but only after the cool down timers have timed out and there is no remote start signal being sent to the unit.

**WARNING: EQUIPMENT DAMAGE**

Always make sure the generator runs under no load for five minutes before stopping to allow the engine and components to cool down. Don't use the E-Stop as the standard.

**AUTO MODE**

To activate the automatic start mode you will just need to depress the AUTO button, the LED indicator beside the button confirms that the unit is in automatic mode.

To test the Automatic Transfer Switch, follow the instruction on the operator's manual that came with the transfer switch. If you get a fault during the initial start up or prior to start up, it is most likely a false warning light. Simply reset the ATS to start over.

Once you have completed testing of the ATS, be sure you ALWAYS leave the system in the standby mode, unless servicing the unit. For standby operation, press the AUTO button on the front of the control. The green light should light up next to the AUTO button.

NOTE: For setting the exerciser circuit, for all ATS, see the operator's manual shipped with the ATS.

**CONTROL POWER**

The DSE7310 controller consumes small amounts of battery power when it is in use. The controller comes with a power switch that disconnects battery power when it is not in use. The switch is designed with a safety relay that prevents it from removing power to the controller while the generator is operating. If the switch is turned off while the engine is running it will continue operating until the engine shuts down and then the controller will power down.

This switch should be used when the generator is not going to be used over the course of several days and the generator is not connected to a battery charger.

A solar charger kit is the easiest way to always maintain the battery during storage in mobile applications. The supplied battery charger can be plugged in to an extension cord on mobile applications.

**AVR WIRING**

**AS540 Automatic Voltage Regulator**

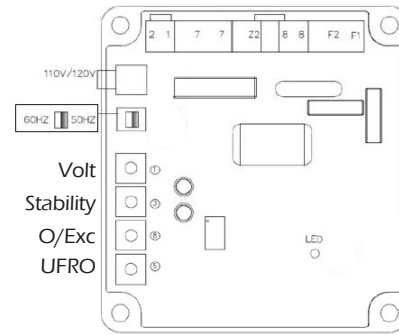

The following is a list of connections on the AVR. These have been factory set and other than voltage adjustment, should never be changed.

**VOLTS**

To adjust generator output voltage.  
Clockwise to increase voltage.

**STABILITY**

To prevent voltage hunting.  
Clockwise to increase the dampening effect.

**UFRO - Under Frequency Roll Off**

Terminal S1 is connected to the C.T., S2 on the AVR.

**O/Exc - Adjust over-excitation trip**

**LED Indicator Light** - indicates over excitation condition or under speed running.



# OPERATING CONDITIONS

---

## NORMAL OPERATION

This generator set is designed to be operated under load and the accumulation of operating hours without load can cause unburned fuel from the combustion chamber to build up in the exhaust system. This is called wet stacking and can result in fouled injectors and carbon buildup in the exhaust pipes, turbo and exhaust valves.

To avoid wet stacking the operating temperatures must be kept high enough. The best way to do this is to ensure that the generator set has adequate load during operation. If the engine is cold at start up run it for 2-5 minutes and then load the generator. Idling longer than this is more likely to damage the engine than extend its life

If the generator application is for emergency standby the generator should be exercised at least monthly ideally under load. Load banking the generator at least annually will help keep the engine in good condition.

## HARSH ENVIRONMENTS OPERATIONS

Some applications require the generator to operate in harsh environments. One of the most common hazards are extremely dusty conditions. In harsh conditions it is often necessary to take additional steps to keep the equipment clean and operating at its peak. Maintenance intervals on lubricant and filter changes may need to be shortened. An oil quality testing program can also provide early warnings or oil degradation. Efforts may need to be made to reduce the amount of dust and debris entering the housing and generator components.

## COLD WEATHER OPERATIONS

The minimum natural starting temperature with glow plugs is -5°F. The minimum starting temperature with glow plugs and block heater is -13°F.

The degree of fluidity of the diesel oil may be reduced at low temperatures due to the separation of the paraffin. This results in the filters becoming clogged.

The ASTM D975 specifications distinguish different classes of diesel fuel, identifying the characteristics of those that are best adapted to low temperatures.

Oil companies must respect these standards, which provide for the distribution of fuels adapted to the climatic and geographical conditions in various countries.

This generator-engine set needs load and should not idle for long periods of time.

If the generator set will be run in extremely cold environments it may be beneficial to provide means to reduce air circulation to increase the temperature of the enclosure.

Inspect the hoses regularly during cold operation looking for signs of freezing. If the line freezes it will cause pressure to build in the crankcase and may cause an engine seal failure. If the engine operates below optimal temperatures for long periods of time damage may occur.

# MAINTENANCE

## WARNING: PERSONAL INJURY/EQUIPMENT DAMAGE

Place controller in manual mode, e-stop applied first. If an auto start signal comes on during maintenance, it may result in injury, death and equipment damage.

## CHANGING THE OIL

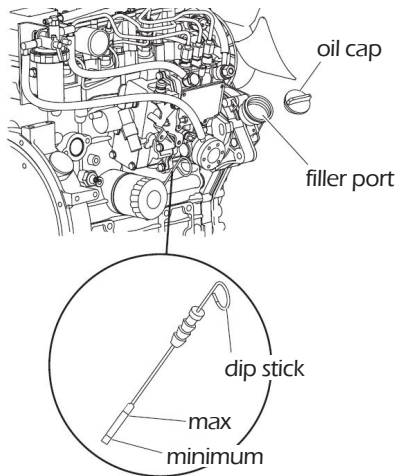

WINCO pipes the oil change to the outside for convenient maintenance.

WINCO recommends our 5W-30 fully synthetic heavy duty engine oil to give you maximum cold weather protection while maintaining excellent performance in warmer weather. We have partnered with a national lubrication oil manufacturer to give you access to Winco private branded premium oil available at comparable prices to conventional oils. See your dealer for additional information.

## CAUTION: PERSONAL INJURY

Only change oil when the engine is not running and is at a low temperature in order to avoid the risk of burns.

1. Remove one of the oil caps to vent the engine crankcase and allow the oil to drain more easily.
2. Place a drip pan or suitable container for catching the oil. WINCO has supplied a valve on the skid frame to hook a customer supplied 5/8" hose to conveniently run the oil to the drip pan.
3. Drain the oil.
4. Once the oil has fully drained, close the valve.
5. Top-off through the filler port using lubricant oil with the suitable oil table in the LUBRICATION section of this manual.
6. Use the dip stick to ensure the level of oil does not exceed the "MAX" limit.
7. Insert the dipstick and close the lubricant oil cap.

8. Dispose of oil in accordance to local codes. DO NOT dispose or allow oil to seep into the ground or sewer systems, doing so will cause environmental damage.

## CHANGING OIL FILTER

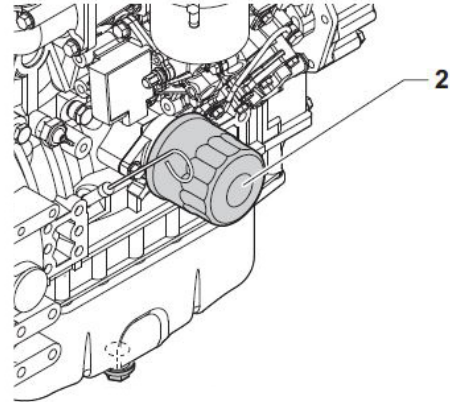

The filter must be replaced when the lubricant oil is changed.

Only use filters with a filtering degree equal to the original filter.

## CAUTION: PERSONAL INJURY

Only change oil when the engine is not running and is at a low temperature in order to avoid the risk of burns.

1. Use an oil filter wrench to unscrew and remove the oil filter (2) and recover the gasket.
2. Lightly coat the gasket on the new oil filter with engine oil.
3. Install the new engine oil filter manually by turning it clockwise until it contacts the mounting surface. Tighten to 14 - 17 ft-lb or one additional turn using the oil filter wrench.
4. Warm up the engine by running it for 5 minutes and check for any oil leaks.
5. Recheck the oil level using the dipstick.
6. Add engine oil to engine oil filler port as needed until the level is between the maximum and minimum lines shown on the dipstick.

## FILLING COOLANT

### CAUTION: PERSONAL INJURY

Only fill coolant when the engine is not running and is at a low temperature in order to avoid the risk of burns.

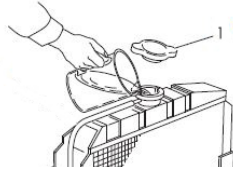

1. Ensure the radiator plug located at the bottom of the radiator and the plug on the engine block are secure.
2. Remove the cap (1) and slowly pour the coolant into the radiator until it is even with the lip of the filler port. Ensure no air bubbles develop.
3. Reinstall radiator cap.

## CHANGING COOLANT

Engine coolant contaminated with rust or water scale reduces the cooling effect. Even when extended life engine coolant is properly mixed, the engine coolant gets contaminated as its ingredients deteriorate. Drain, flush and refill the cooling system with new coolant every 1000 hours or once a year, whichever comes first.

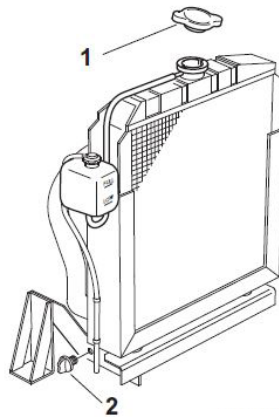

### CAUTION: PERSONAL INJURY

Only proceed when the engine is not running and is at a low temperature in order to avoid the risk of burns.

1. Remove the cap (1) on the radiator.
2. Remove the drain plug (2) at the bottom of the radiator and drain the coolant into an approved container. Reinstall plug.
3. Remove the coolant drain plug from the engine block. (see (1) in the following figure)

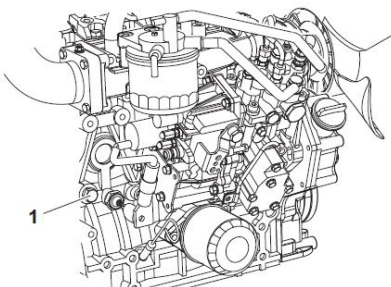

4. After draining the engine coolant, flush the radiator and engine block to remove any rust, scale and contaminants. Then reinstall and tighten the drain plug

or close the drain valve in the radiator. Reinstall and tighten the engine block drain plug.

5. Fill radiator and engine with engine coolant.

## CLEANING RADIATOR

The surfaces of the radiator come into contact with the outside air and can be subject to deposits and impurities. Clean in accordance to the maintenance schedule with compressed air or steam.

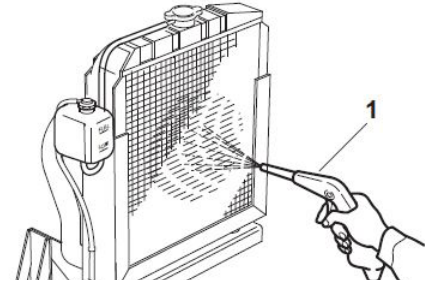

### CAUTION: PERSONAL INJURY

Always wear eye protection when servicing the engine and when using compressed air or high-pressure water. Dust, flying debris, compressed air, pressurized water or steam may injure your eyes.

1. Blow off dirt and dust from fins and radiator with 28PSI or less compressed air. Be careful not to damage the fins with the compressed air (1).
2. If there are larger amount of contamination on fins, apply detergent, thoroughly clean and then rinse with tap water.

## CHANGING AIR FILTER

The engine performance is adversely affected when the air cleaner element is clogged with dust.

### WARNING: EQUIPMENT DAMAGE

Never operate the engine with the air cleaner element removed. This may allow foreign material to enter the engine and damage it. Do NOT remove filter while engine is running.

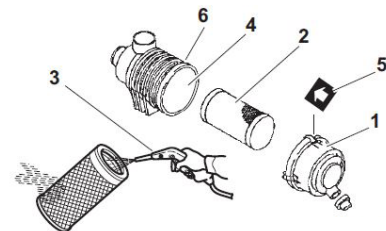

1. Unlatch and remove the air cleaner cover (1).
2. Remove the element (2).
3. Blow air (Figure 13, (3)) through the element from the inside out using 42 - 71 PSI compressed air to remove the particulates. Use the lowest possible air pressure to remove the dust without damaging the element.

4. Replace the element with a new one if the element is damaged, excessively dirty or oily.
5. Clean inside of the air cleaner cover.
6. Reinstall the element into the air cleaner case (4).

Note: If there is a red line (2) in the outer element, reinsert the element until the overlap position of red line and end face of the air cleaner case.

8. Reinstall the air cleaner cover making sure you match the arrow (5) on the cover with the arrow on the case (6).
9. Latch the air cleaner cover to the case.

## DRAINING WATER SEPARATOR

### WARNING: FIRE AND EXPLOSION HAZARD

Diesel fuel is flammable and explosive under certain conditions.

Drain the water separator whenever there are contaminants, such as water, collected in the bottom of the cup. Never wait until the scheduled periodic maintenance if contaminants are discovered.

The separator cup is made from semi-transparent material. In the cup is a red-colored float ring. The float ring will rise to the surface of the water to show how much needs to be drained.

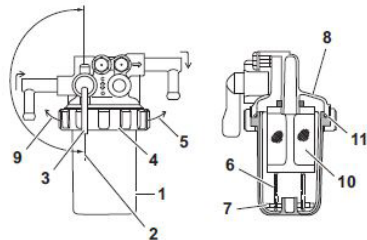

1. Position an approved container under the water separator (1) to collect the contaminants.
2. Close (2) the fuel valve (3).
3. Turn the retaining ring (4) to the left (9).
4. Carefully remove the cup (1). Remove the retaining spring (6) and float (7) from the cup. Pour the fuel into an approved container and dispose of waste properly. Hold the bottom of the cup with a shop towel to prevent the fuel from dripping. Wipe up any spills immediately.
5. Clean the inside of the cup.
6. Inspect the condition of the mesh filter (10). Clean the mesh filter if necessary.
7. Inspect the condition of the O-ring (11). Replace the O-ring if necessary.
8. Put the float (7) and retaining spring (6) inside the cup.
9. Reinstall the cup to the mounting flange (8) and turn the retaining ring (4) to the right (5). hand-tighten only.

10. Open the fuel valve (3).
11. Be sure to prime the diesel fuel system when you are done.
12. Check for fuel leaks.

Follow the guidelines of the EPA or other governmental agencies for the proper disposal of hazardous materials such as engine oil, diesel fuel and engine coolant. Consult the local authorities or reclamation facility.

Never dispose of hazardous materials irresponsibly by dumping them into a sewer, on the ground, or into ground water or waterways.

## CLEANING WATER SEPARATOR

### WARNING: FIRE AND EXPLOSION HAZARD

Diesel fuel is flammable and explosive under certain conditions.

Do NOT perform while the engine is running.

1. Position an approved container under the cup (1) of the water separator to collect the contaminants.
2. Close (2) the fuel valve (3).
3. Loosen the drain valve (4) and drain the contaminants.
4. Turn the cup (1) to the left (10), remove the cup (1).
5. Carefully hold the cup to prevent fuel from spilling. If you spill any fuel, clean up the spill completely.

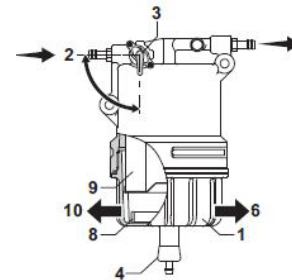

## ADJUSTING THE GOVERNOR

Never attempt to adjust the low or high idle speed limit screw. This may impair the safety and performance of the machine and shorten its life. If adjustment is ever required, contact your Isuzu Distributor.

1. Check that the governor lever (1) makes firm contact with the high idle stop (2) and the low idle speed limit screw (3) when the engine speed control is in the full speed or low idle speed positions.
2. If the governor lever does not make proper contact with the high idle stop or the low idle speed limit screw, adjust the throttle cable or linkage as necessary.

## WARNING: EQUIPMENT DAMAGE

Do not force the throttle cable or linkage to move. This may damage the the governor lever, the throttle cable or linkage and cause irregular operation of the engine speed control.

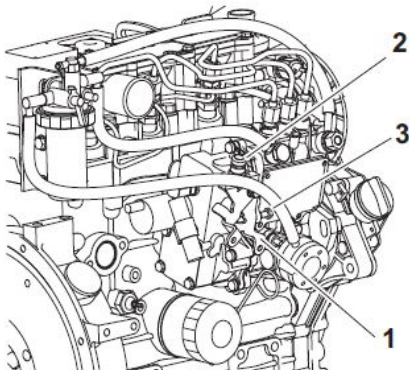

## STORAGE

### PREPARING THE ENGINE FOR A LONG PERIOD OF INACTIVITY

In the case of a planned period of inactivity that lasts longer than two months, to prevent the interior parts of the engine and some components of the injection system from oxidizing, prepare the engine as follows:

1. Perform the next Preventive Maintenance procedure. For example, if there are 10 hours remaining before the 250 hour maintenance, you should do the maintenance before you place the engine in storage.
2. Flush the radiator and refill with Long Life Engine Coolant.
3. Clean the exterior of the engine so it is free of grease and oil.
4. Drain the fuel tank or make sure it is completely full.
5. Lubricate exposed parts of the engine speed control system.
6. Protect the air cleaner, muffler and electrical components (alternator, starter motor, switches, controller) from water and dust.
7. Disconnect the negative (-) battery cable to prevent the battery from discharging. Charge the battery once a month during storage.
8. Rotate the engine without starting, every four to six months.

## RETURNING ENGINE TO SERVICE

1. Perform the Daily Checks.
2. The engine should be pre-oiled before startup. Crank the engine, leaving the fuel system shut off so the engine will not start, for 15 seconds. Then pause for 30 seconds. Repeat the procedure until you have cranked the engine for a total of one minute. This will circulate the oil in the engine's lubrication system.
3. Prime the fuel system.
4. Start the engine. Allow the engine to idle for approximately 15 minutes while you check for:
  - Proper oil pressure
  - Fuel, engine oil, or coolant leaks
  - Proper operation of the indicators and/or gauges.
5. Avoid prolonged operation at minimum or maximum engine speeds and loads for the remainder of the first hour of operation.

## MAINTENANCE SCHEDULE

COOLING SYSTEM	FREQUENCY
Check and refill engine coolant	Daily
Check and clean radiator fans	Every 250 hours
Check and adjust cooling fan V-Belt	Every 250 hours
Change Coolant	Every 1000 hrs/1yr
ELECTRICAL EQUIPMENT	FREQUENCY
Check indicators	Daily
Check battery and recharge	Every 250 hours
ENGINE OIL	FREQUENCY
Check engine oil	Daily
Drain and fill engine	Every 250 hours
Replace engine oil	Every 250 hours
ENGINE SPEED CONTROL	FREQUENCY
Check and adjust governor lever	Daily/Every 250 hrs
FUEL	FREQUENCY
Drain water separator	Every 50 hours
Check water separator	Daily
Clean water separator	Every 500 hours
Replace fuel filter	Every 500 hours
HOSES	FREQUENCY
Check and replace fuel hoses	Every 2000 hrs/2yrs
INTAKE & EXHAUST	FREQUENCY
Clean air cleaner element	Every 250 hours
Replace air cleaner element	Every 500 hours
COMPLETE ENGINE	FREQUENCY
Overall visual check	Daily

Note: Some operating conditions may require more frequent maintenance intervals.

# TROUBLE SHOOTING TABLES

Problem	Possible Causes
Unit will not crank when power fails	Digital genset not in AUTO Transfer control switch not in AUTOMATIC position Incorrect wiring between ATS and genset Defective control relay in ATS Fuse(s) blown in the DSE 7310 Defective DSE 7310 Loose or dirty battery terminals Defective starter Defective start solenoid Low/dead battery
Engine won't crank	Low/dead battery Blown DC fuses Defective DSE 7310 Defective key switch Loose or dirty battery terminals Defective starter Defective start solenoid Locked up engine genset Defective engine harness Improper battery voltage to start solenoid, fuel pump, or fuel solenoid
Engine cranks but will not start	Improper fuel delivery to the unit Fuel supply shut off Fuel tank empty Air in the fuel system Engine fuel solenoid has not opened Defective fuel pump Defective fuel solenoid Defective engine harness Improper battery voltage to fuel pump or fuel solenoid
Engine starts, then stops and alarm light comes on	Engine oil pressure is low Engine has high water temperature Engine has overspeed Engine has gone into overcrank No output from AC generator Loss of speed signal Loss of run signal
Engine will not come up to speed after it starts	Insufficient fuel volume getting to the unit 1. Too small of fuel line 2. Fuel racks not open properly Governor is defective AC short in generator components
ATS will not transfer to Emergency Supply (generator)	No AC generator output Defective ATS control board. See ATS manual Circuit breaker open or defective
ATS will not re-transfer to normal power	Proper power line not available at line terminals in ATS panel Defective ATS control board. See ATS manual
No AC output from generator	Defective diode Defective voltage regulator Defective rotor Defective stator Defective exciter rotor Defective exciter stator AC short in the output leads Defective/open generator output breaker Wiring error

# WIRING SIZE TABLE

The table below is based on Table 310.15 (B) (16) in the National Electric Code 2014 edition. Allowable ampacities of insulated conductors rated 0 through 2000V, 75°C through 90°C. Not more than three current-carrying conductors in Raceway, Cable, or Earth (direct buried). Adjust for 40°C (104°F) ambient temperature.

Copper 75°C	Copper 90°C		Aluminum Copper Clad Aluminum 75°C	Aluminum Copper Clad Aluminum 90°
Wire Type: RHW, THHW, THW, THWN, XHHW, USE, ZW	Wire Type: TBS, SA, SIS, FEP, FEPB, MI, RHH, RHW-2, THHN, THHW, THW-2, XHH, XHHW, XHHW- 2, ZW-2	SIZE AWG OR KCMIL	Wire Type: RHW, THHW, THW, THWN, XHHW, USE	Wire Type: TBS, SA, SIS, THHN, THW-2, THWN-2, RHH, RHW-2, USE-2, XHH, XHHW, XHHW-2, ZW-2
50	55	8	40	45
65	75	6	50	55
85	95	4	65	75
100	115	3	75	85
115	130	2	90	100
130	145	1	100	115
150	170	1/0	120	135
175	195	2/0	135	150
200	225	3/0	155	175
230	260	4/0	180	205
255	290	250	205	230
285	320	300	230	260
310	350	350	250	280
335	380	400	270	305
380	430	500	310	350
420	475	600	340	385
460	520	700	375	425
475	535	750	385	435
490	555	800	395	445
520	585	900	425	480
545	615	1000	445	500
590	665	1250	485	545
625	705	1500	520	585
650	735	1750	545	615
655	750	2000	560	630

For additional information, see table 310.15 of the National Electric Code.

# WIRING DIAGRAMS

## THREE PHASE AC WIRE HIGH AND LOW WYE

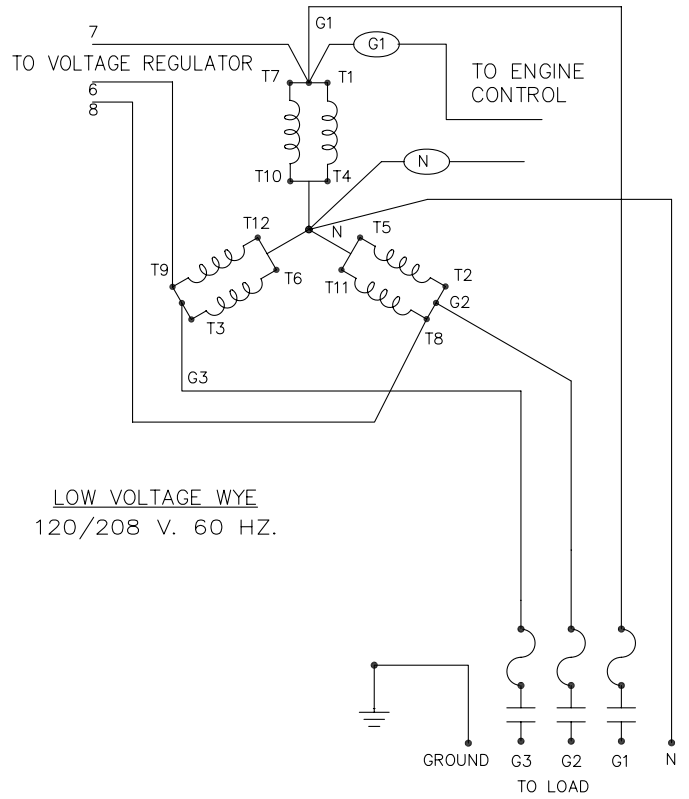
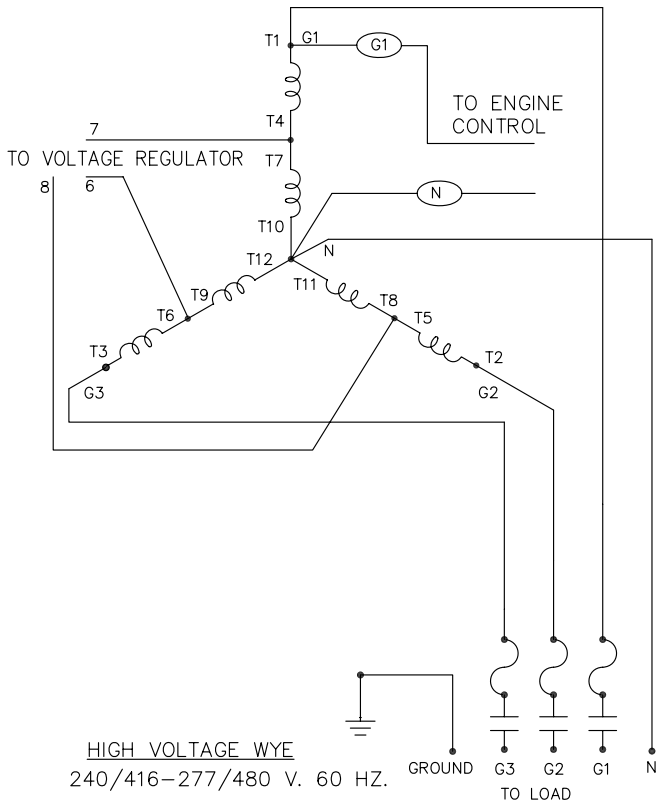

## THREE PHASE AC WIRING-DELTA

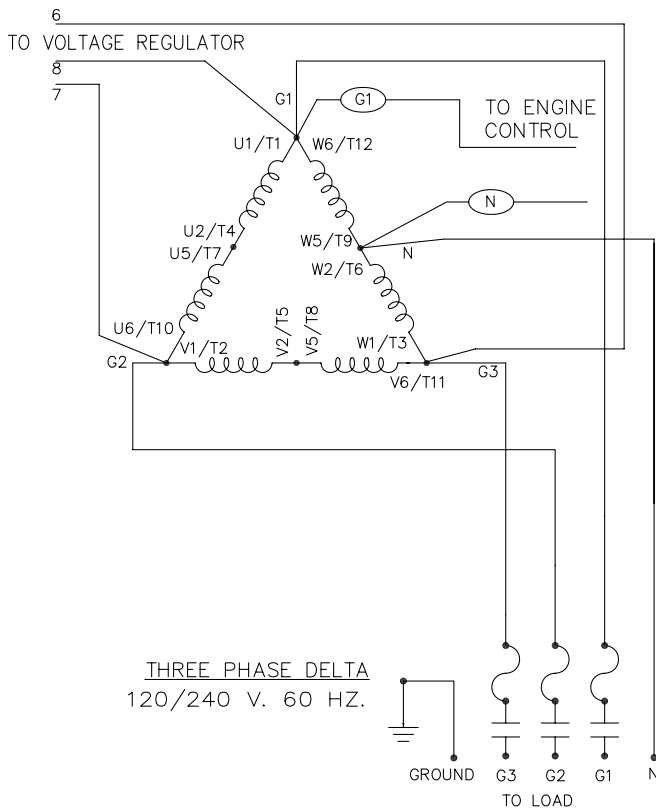

## SINGLE PHASE 311 WINDING

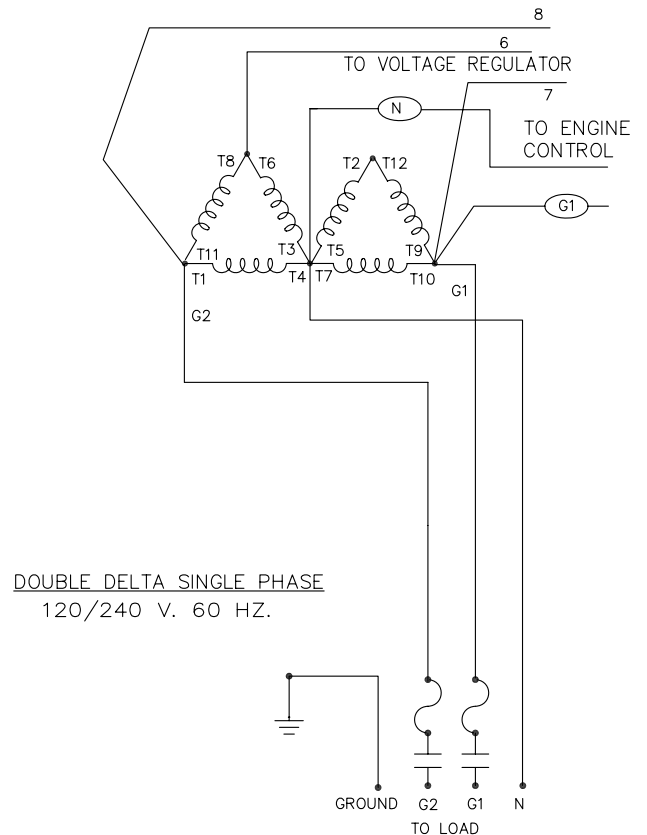



# DSE7310 WIRING DIAGRAM

LEGEND:  
 PS: POWER SWITCH  
 ESS: EMERGENCY STOP SWITCH  
 FSS: FUEL SELECTION SWITCH  
 VAR: VOLTAGE ADJUSTMENT RHEOSTAT

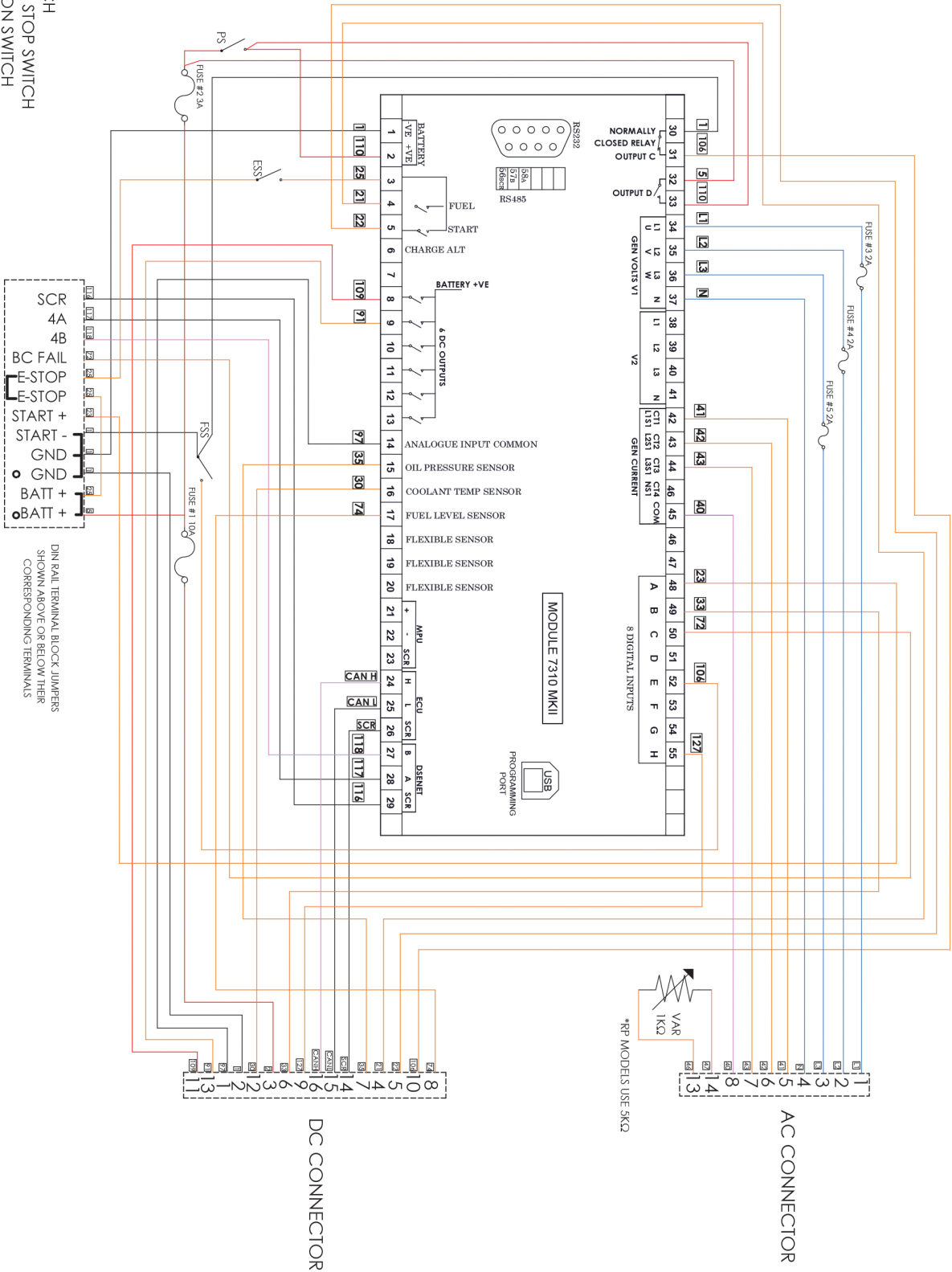

# LIMITED WARRANTY

---

WINCO Incorporated warrants to the original purchaser for the warranty period that goods manufactured or supplied by it will be free from defects in workmanship and material, provided such goods are installed operated and maintained in accordance with WINCO written instructions.

WINCO's sole liability, and Purchaser's sole remedy for a failure under this warranty, shall be limited to the repair of the product. At WINCO's option, material found to be defective in material or workmanship under normal use and service will be repaired or replaced. For warranty service, contact a Winco Authorized Service Center within the warranty period from date of purchase.

\*NOTE: Units that are resold by original owner are not covered under this warranty. Any further warranty, whether expressed or implied, rests solely with the reseller.

## THERE IS NO OTHER EXPRESS WARRANTY.

To the extent permitted by law, any and all warranties, including those of merchantability and fitness for a particular purpose, are limited to the warranty period from date of purchase. In no event is WINCO liable for incidental or consequential damages.

Note: Some states do not allow limitation on the duration of implied warranty and some states do not allow the exclusion or limitation of incidental or consequential damages, so the above limitations may not apply in every instance. This warranty gives you specific legal rights which may vary from state to state.

## WINCO, INC. WARRANTY EFFECTIVE DATE

Air cooled units purchased for stock have 1 year to be sold. The warranty to the original retail customer commences on the date of sale of the product to them. All liquid cooled units have 180 days from the Winco invoice to submit a start up date. If no startup form is submitted, then warranty period starts on the Winco invoice date unit was sold.

Date of sale is defined as the day the customer takes delivery of the product. This warranty shall remain in effect to the original purchaser for the period stated on the sales literature. The warranty is not transferable and the retail customer must retain his original bill of sale as proof of purchase date.

WINCO, Inc. agrees to the following obligations during the warranty period:

1. To warrant any defect in material or workmanship of products sold under the WINCO and DYNA brand names in accordance with the warranty statements in the operator's manuals.
2. To reimburse authorized WINCO, Inc. Service Centers/Dealers for the cost of parts plus standard ground UPS shipping charges for all valid warranty repairs and to reimburse same said service centers/dealers for reasonable labor charges based on WINCO's current warranty labor reimbursement rate.
3. To furnish its authorized service centers/dealers with the necessary parts to make the repairs. WINCO Generator Warranty Periods & Restrictions

## WINCO GENERATOR WARRANTY PERIODS & RESTRICTIONS

### Industrial Portables

WL Models - 3 Years, See Notes 1 & 2

W Models - 3 Years, See Notes 1, 2, & 5

DP Models - 3 Years, See Notes 1 & 2

HPS Models - 2 Years, Home Use ONLY; Commercial use\* is 90 Day Warranty, See Note 1

### EMERGEN-C (EC) Series

2 Years, See Note 1

### DE Series

1 Year/2000 hours, No Travel Time

Mobile Diesel Series

1 Year/2000 hours, No Travel Time

### PTO Series

15kW & 10kW - 1 Year, Limited Farm Standby Only

25kW thru 165kW - 3 Years, Limited Farm Standby Only/Commercial use\* 1 Year

### Two Bearing Series

1 Year, Bench Labor and Parts only

### Gaseous/Packaged Standby Series (PSS)

Air-Cooled Models (PSS8, PSS12, & PSS20) – 2 Years/2000 Hours Standby Only See Notes 3 & 4 Prime Power use 1 Year/2000 Hours See Notes 3 & 4

Liquid-Cooled Models (PSS21 - PSS150) - 2 Years/2000 Hours Standby Only See Notes 3 & 4 Prime Power use 1 Year/2000 Hours See Notes 3 & 4

### Diesel Standby Series (DR)

Liquid-Cooled Models (DR12 - DR600) - 2 Years/2000 Hours Standby Only See Notes 3 & 4

Prime Power use 1 Year/2000 Hours See Notes 3 & 4

Accessories (Installed on Generator or shipped loose)

1 Year from factory invoice or 2000 Hours (whichever occurs first)

## Automatic Transfer Switches (ATS)

See ATS Manufacturer's Warranty

### NOTES

Note 1: First 2 years of warranty coverage includes Parts and Bench Labor Only, no travel time or labor allowance for removal or reinstallation of the product from its application.

Note 2: 3rd Year warranty coverage is parts only/no labor.

Note 3: Round trip mileage is limited to 200 miles per trip and a total of 2 trips per repair unless authorized in writing by the WINCO Service Dept.

Note 4: Mileage allow on permanently installed units only. Trailer mount units is bench labor only.

Note 5: W3000 is a 1 Year Warranty.

\*Commercial use is defined as Construction, Rental, Prime Power, or use in a business of any type including agricultural and hobby. Prime Power use is defined as any application where the generator set is being used 'off-grid' where there is no utility power present. Standby use is defined as an application where utility power is present -and- the generator set is used as emergency backup during utility power outages.

WINCO reserves the right to change or improve it's products without incurring any obligations to make such changes or improvements on products purchased previously.

### EXCLUSIONS:

WINCO does not warrant Engines. Engines are covered exclusively by the warranties of their respective manufacturers.

WINCO does not warrant Batteries, or Other Component Parts that are warranted by their respective manufacturers.

WINCO does not warrant modifications or alterations which were not made by WINCO, Inc.

WINCO does not warrant products which have been subjected to misuse and/or negligence or have been involved in an accident.

This warranty does not include travel time, mileage, or labor for removal or reinstallation of WINCO product from its application, unless specifically authorized.

### WHAT IS COVERED BY WARRANTY

1. Generator end including rotor, stator, end brackets, and bearing.
2. Control box including transformers, circuit breakers, wiring, resistors, and switches.
3. LP/NG fuel system including fuel solenoid, demand regulator, carburetor, and hoses.
4. Cradle assembly including cradle, cross member, and shock mounts that fail. Shock mounts damaged from rough handling are not covered.
5. Reasonable travel time for the PSS & DR series generators only, that are permanently installed.
6. Ground shipping charges for warranty parts, no premium service, domestic US shipments only.

### WHAT IS NOT COVERED BY WARRANTY

1. Products which have been subjected to alteration, modification, neglect or unauthorized repairs not approved in writing by Winco, Inc.
2. Products no longer owned by the original purchaser.
3. Products with shipping or freight damage. File a freight claim with the delivery carrier.
4. Products suffering normal wear, accidents, improper maintenance or improper protection in storage. Products damaged by rough handling, such as shock mounts on cradle assemblies.
5. Pressure or steam cleaning of products, cleaning of fuel system, or flushing of cooling system.
6. Replacement of filter, belts, antifreeze, or lubricants.
7. Electrical items, such as light bulbs, receptacles, spark plugs, or any items damaged by welding or jump starting.
8. Any repeat or shop come-back repairs resulting from poor service work or improper diagnosis and testing. Replacement of parts as a trial-and-error method of diagnosis will not be considered for warranty.
9. Replacement parts other than those sold by Winco, Inc.
10. Damage caused by fire, flood, lightning or any other natural disaster.
11. Damage caused by improper protection during installation, (i.e. not protecting contactor in the ATS panel and getting wire trimming or debris from drilling the box in the contactor coil or contacts.)
12. Damage caused by over loading of the generator and failure to adequately provide overload protection.
13. LP/NG fuel adjustments or conversion from one fuel to another.
14. Adjustment of any kind, all units are 100% load tested before shipping.
15. Any damage caused by the use of the equipment for purposes other than for which it was designed.
16. Engines - All engines used by Winco, Inc. are warranted by their respective manufacturer's.
17. Batteries - Must be returned to original battery manufacturer.
18. Damage caused by improper installation or failure to provide adequate ventilation.
19. Cosmetic repairs, such as repainting.
20. Freight charges for transportation to and from a Warranty Service Center.
21. Rental costs of renting replacement generators.
22. Travel time or service calls unless specifically authorized by Winco, Inc. in writing.

### GENERAL INFORMATION

The WINCO, Inc. Service Department is open from 7:30 AM to 4:30 PM Central Standard time.

It is located at 225 South Cordova Ave., Le Center, MN, 56057-1805.

Phone Numbers: Service Department - 507-357-6831 FAX Line - 507-357-4857. Email address is service@wincogen.com

The phone number to for the General Switchboard/Sales Department is 507-357-6821.

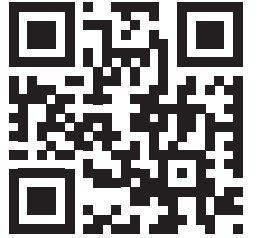

**WINCO<sup>®</sup>**  
**GENERATORS**



AN AMERICAN COMPANY

225 S. CORDOVA AVE • LE CENTER, MN 56057

Sales: 507-357-6821 • [sales@wincogen.com](mailto:sales@wincogen.com)

Service: 507-357-6831 • [service@wincogen.com](mailto:service@wincogen.com)

[www.wincogen.com](http://www.wincogen.com)

